

Introduction (1)

GI-1

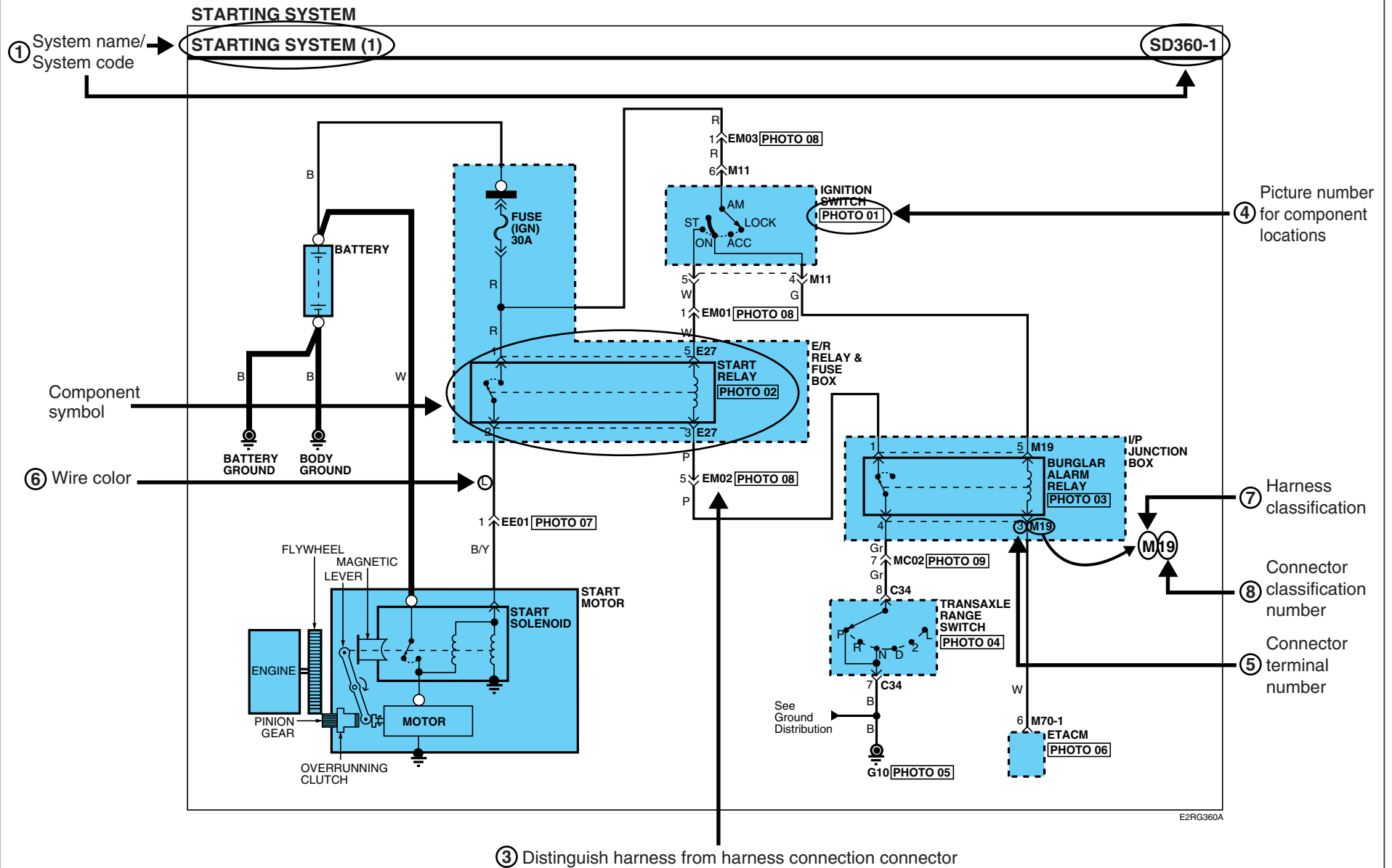

# INTRODUCTION

## Introduction (2)

GI-2

### STARTING SYSTEM

#### STARTING SYSTEM (2)

SD360-2

② Connector configurations (components)

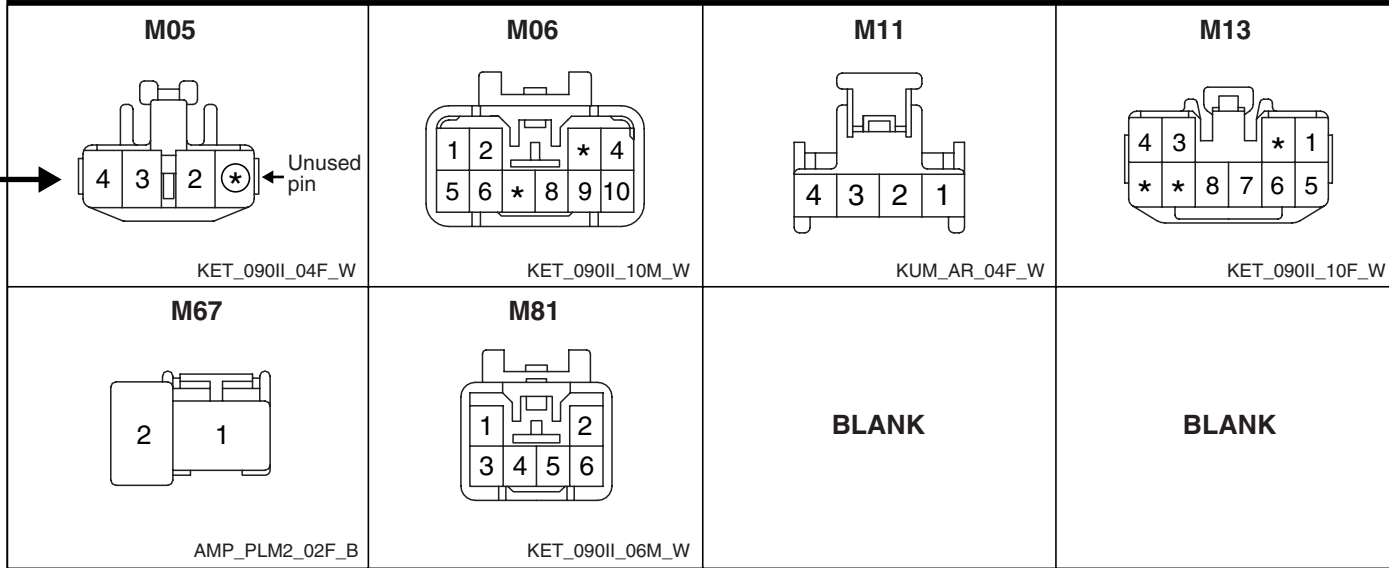

E2RG360B

Explanation of connector code

### M05

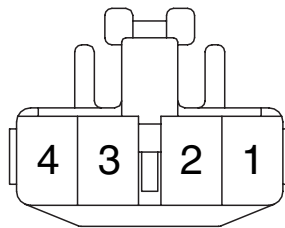

KET\_090II\_04F\_W

a b c d e

a : Connector manufacturer

b : Terminal series number

c : The number of connector terminals

d : Connector distinguishing

- Female Pin : F
- Male Pin : M

e : Connector color abbreviations

- B (Black)
- Br (Brown)
- G (Green)
- Gr (Gray)
- L (Blue)
- R (Red)
- W (White)
- Y (Yellow)

# INTRODUCTION

## Introduction (3)

GI-3

### ① Pages by system/ Name of Schematic diagram

- Each page is consisted of circuits by system. This schematic diagram includes the path of electricity flow, connection condition for each switch, and the function of other relevant circuits at once. It is applicable to real service work.
- It is very important to understand relevant circuits exactly before troubleshooting diagnosis.
- Circuits by system depends upon part number and are indicated on schematic diagram index.

### ② Connector configuration (components)

- The connector figure of components in the schematic diagram by system is indicated on the last page of schematic diagram.
- It shows the front of the connector on the harness side when not to the harness connector. The terminal number on each connector can be obtained by following the pattern used in ⑤ connector view and numbering order. Unused terminals are marked with an asterisk (\*).

### ③ Connector configurations (connection between harnesses)

- When connecting the harness with connector between harnesses, it shows female and male connectors and indicates them on the connector configurations group.

EM02

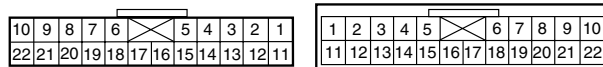

### ④ Component locations

- To find the components easily, a component locations diagram is indicated with "PHOTO NO" on the lower portion of the component name.
- To make it easy to distinguish connectors, the connector in the picture is indicated being installed in the vehicle.

PHOTO 03

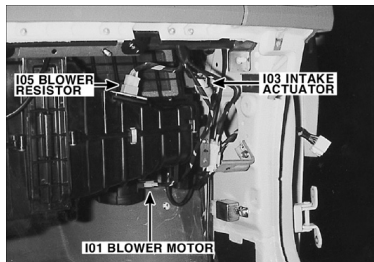

### ⑤ CONNECTOR VIEW AND NUMBERING ORDER

Female	Male	Remarks
		<p>It is not the shape of the connector housing, but the connector pin that distinguishes between male or female connectors. When numbering female and male connectors, refer to the numbering order in the following table. Some connectors may not follow this method of numbering order. For individual detailed numbering, refer to the CONNECTOR CONFIGURATIONS.</p>
		<p>Numbered in order from upper right to lower left</p> <p>Numbered in order from upper left to lower right</p>

### NOTE

UNLESS OTHERWISE STATED, ALL CONNECTOR VIEWS ARE FROM THE TERMINAL SIDE OF THE CONNECTOR.

# INTRODUCTION

## Introduction (4)

GI-4

### ⑥ WIRE COLOR ABBREVIATIONS

The following abbreviations are used to identify wire colors in the circuit schematics.

Symbol	Color of wire	Symbol	Color of wire
B	Black	O	Orange
Br	Brown	P	Pink
G	Green	R	Red
Gr	Gray	W	White
L	Blue	Y	Yellow
Lg	Light Green	Pp	Purple
T	Tan	LI	Light Blue

\* **(Y/B)**: Black stripe with yellow ground (2 colors)

↑                      ↑  
the color of        the color of  
background        stripe

### ⑦ HARNESS CLASSIFICATION

Electrical wiring connectors are classified according to the wiring parts in the Harness Layouts.

Symbol	Harness name	Location
C	Control, Ignition Coil harness	Engine/Passenger compartment
D	Driver/Passenger Door harness, Rear Door LH/RH harness	Door
E	Front, Front End Module harness Battery harness	Engine compartment, Battery
F	Floor, BWS EXT. harness	Floor, Bumper
M	Main, Console EXT. harness	Passenger compartment, Under Crash pad
R	Roof harness	Roof

\* It depends on vehicles, it is necessary to check the harness name symbol on the harness layouts for detailed symbol.

### ⑧ CONNECTOR IDENTIFICATION

A connector identification symbol consists of a wiring harness location classification symbol corresponding to a wiring harness location and number corresponding to the connector. These connector locations can be found in the HARNESS LAYOUTS.

For example:

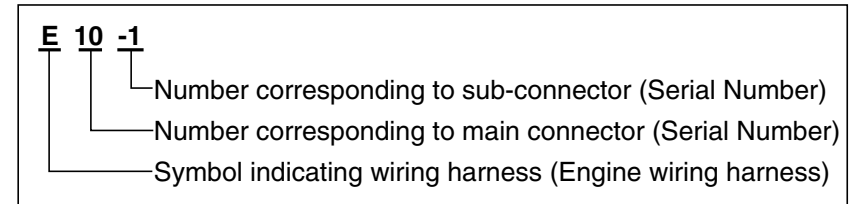

#### NOTE

**Connectors which connect each wiring harness are represented by the following symbols.**

For example:

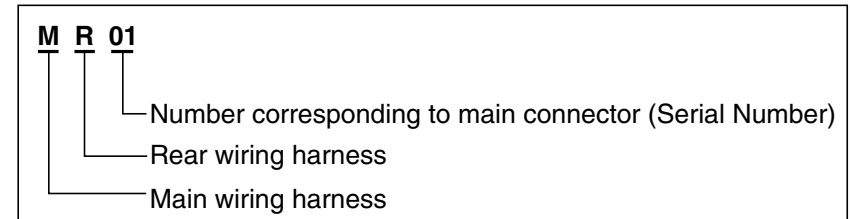

### JUNCTION BLOCK IDENTIFICATION

A junction block identification symbol consists of a wiring harness location classification symbol corresponding to a wiring harness location and number corresponding to the connector in the junction block.

For example:

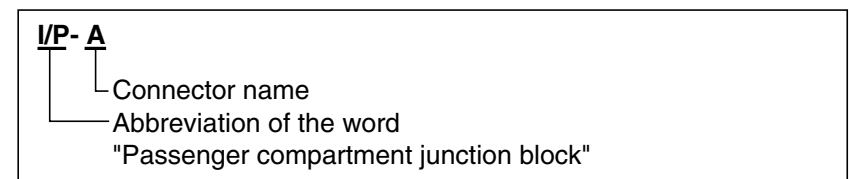

**HARNESS LAYOUTS**

Harness layouts show the routing of the major wiring harnesses, the in-line connectors and the splices between the major harnesses. These layouts will make electrical troubleshooting easier.

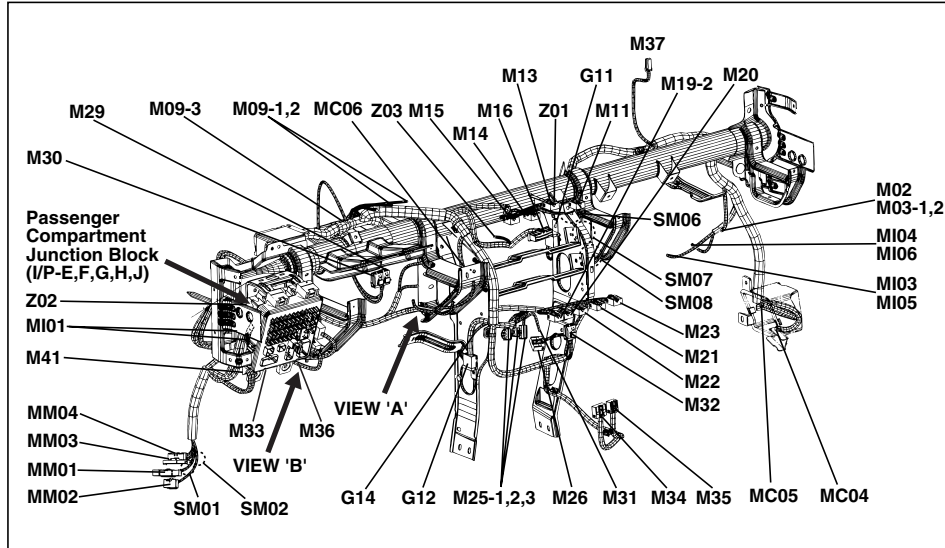









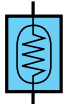
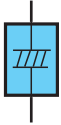

Symbols (1)

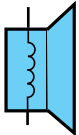
Section	Symbol	Meaning	Section	Symbol	Meaning	Section	Symbol	Meaning	Section	Symbol	Meaning
C O M P O N E N T		A solid line means the entire component is shown.	C O N N E C T O R		Shows the name of each connector on the component location index for reference.  Indicates the number of corresponding terminal. (Only relevant terminal on the corresponding schematic diagram).  The dashed-line means each of two wires connect with same connector(E35)	S H I E L D W I R E		This represents RFI (Radio Frequency Interference) Shielding around a wire. The shielding is always connected to ground.	L A M P		Double filament
		A broken line indicates only part of the component is shown.			The dashed-line means each of two wires connect with same connector(E35)			Single filament			
		This means the connector connects directly to the component.	W I R E		A wavy line means the wire is broken but is to be continued.	J O I N T C O N N E C T O R		This is a connector showing the joining wires.	D I O D E		Diode
		This indicates the connector connects to a lead (pigtail), wired directly to the component.			Wire insulation is yellow with a red strip.			Zener diode			
		This indicates the connector connects to a lead (pigtail), wired directly to the component.	S P L I C E S		Current path is continued on the same page or another page. The arrow shows the direction of current flow. You should look for the "A" in the marked position.	S L O W B L O W		Power supplied at all times.  Name Capacity	T R		NPN
		This indicates a screw terminal on the component.			A wire connects to another circuit. The wire is shown again on that circuit which the arrow is pointing.			PNP			
		This ground symbol (dot and 3 lines overlapping the component) means the housing of the component is attached to a metal part of the vehicle.	G R O U N D		Wire choices for options or different models are labeled and shown with a "choice" bracket like this.	F U S E		This means power is supplied with the ignition on position.  This means the short bar connects to other fuses. Identification Current rating	G E N E R A L C O M P O N E N T S Y M B O L		These switches move together: a dashed line shows a mechanical connection between them.
		The name of the component appears next to its upper right corner.  Shows the number of pictures for component location.			Splices are numbered and shown as a dot with circle. The exact location and connection of these splices may vary among vehicles.			Control battery power at all times			Heater

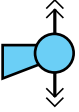
# SYMBOLS

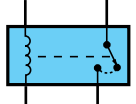
## Symbols (2)

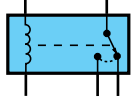
GI-7

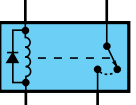
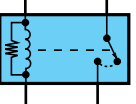
Section	Symbol	Meaning	Section	Symbol	Meaning
GENERAL COMPONENTS SYMBOL		Sensor	GENERAL COMPONENTS SYMBOL		Condenser
		Sender			Speaker
		Injector			Horn, Buzzer, Siren, Chime Bell
		Solenoid	RELAY		Normally open contact
		Motor			This is a relay shown with no current flowing through its coil. When a current flows through coil, contact will toggle.
		Battery			Diode interior relay
				Resistance interior relay	

## Troubleshooting Instructions (1)

GI-8

## TROUBLESHOOTING INSTRUCTIONS

## TROUBLESHOOTING PROCEDURES

The following five-step troubleshooting procedure is recommended.

**1. Verify the customer's complaints**

Turn on all the components in the problem circuit to check the accuracy of the customer's complaints. Note the symptoms. Do not begin disassembly or testing until you have narrowed down the probable causes.

**2. Read and analyze the schematic diagram**

Locate the schematic for the problem circuit. Determine how the circuit is supposed to work by tracing the current paths from the power source through the system components to ground. If you do not understand how the circuit should work, read the circuit operation text. Also check other circuits that share with the problem circuit. The name of circuits that share the same fuse, ground, or switch, for example, are referred to on each diagram. Try to operate any shared circuits you did not check in step 1. If the shared circuit works, the shared wiring is okay, and the cause must be within the wiring used only by the problem circuit.

If several circuits fail at the same time, the fuse or ground is a likely cause.

**3. Inspect the circuit/ component with the problem isolated**

Make a circuit test to check the diagnosis you made in step 2. Remember that a logical, simple procedure is the key to efficient troubleshooting. Narrow down the probable causes using the troubleshooting hints and system diagnosis charts. Test for the most likely cause of failure first. Try to make tests at points that are easily accessible.

**4. Repair the problem**

Once the problem is found, make the necessary repairs.

**5. Make sure the circuit works**

Repeat the system check to be sure you have repaired the problem. If the problem was a blown fuse, be sure to test all of the circuits on that fuse.

## TROUBLESHOOTING EQUIPMENT

**VOLTMETER AND TEST LAMP**

Use a test lamp or a voltmeter on circuits without solidstate units and use a test lamp to check for voltage. A test lamp is made up of a 12-volt light bulb with a pair of leads attached. After grounding one lead, touch the other lead to various points along the circuit where voltage should be present. When the bulb goes on, there is voltage at the point being tested.

**CAUTION**

**A number of circuits include solid-state modules, such as the Engine Control Module(ECM), used with computer command control injection. Voltage in these circuits should be tested only with a 10-megaohm or higher impedance digital multimeter. Never use a test lamp on circuits that contain solid state modules. Damage to the modules may result.**

A voltmeter can be used in place of a test lamp. While a test lamp shows whether the voltage is present or not, a voltmeter indicates how much voltage is present.

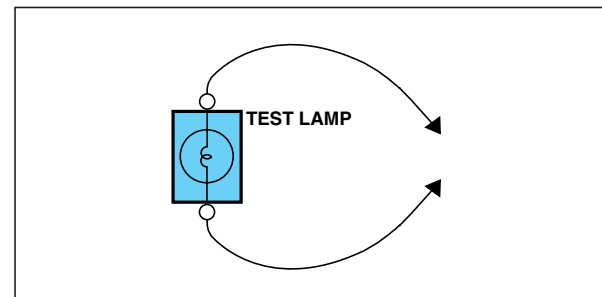
**SELF-POWERED TEST LAMP AND OHMMETER**

Use a self-powered test lamp or an ohmmeter to check for continuity. The ohmmeter shows how much resistance there is between two points along a circuit. Low resistance means good continuity.



## TROUBLESHOOTING INSTRUCTIONS

### Troubleshooting Instructions (2)

GI-9

#### CAUTION

**Never use a self-powered test lamp on circuits that contain solid state modules. Damage to these modules may result.**

An ohmmeter can be used in place of a self-powered test lamp. The ohmmeter shows how much resistance there is between two points along a circuit. Low resistance means good continuity.

Circuits which include any solid-state devices should be tested only with a 10-megaohm or higher impedance digital multimeter. When measuring resistance with a digital multimeter, the battery negative terminal should be disconnected. Otherwise, there may be incorrect readings. Diodes and solid-state devices in a circuit can make an ohmmeter give a false reading. To find out if a component is affecting a measurement, take one reading, reverse the leads and take a second reading. If different the solid-state device is affecting the measurement.

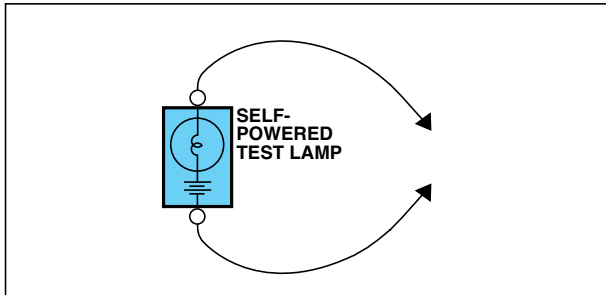

#### JUMPER WIRE WITH FUSE

Use a jumper wire with a fuse to by-pass an open circuit.

A jumper wire is made up of an in-line fuse holder connected to a set of test leads. This tool is available with small clamp connectors providing adaption to most connectors without damage.

#### CAUTION

**Do not use a fuse with a higher rating than the specified fuse that protects the circuit being tested. Do not use this tool in any situation to substitute an input or output at the solid-state control module, such as ECM, TCM, etc.**

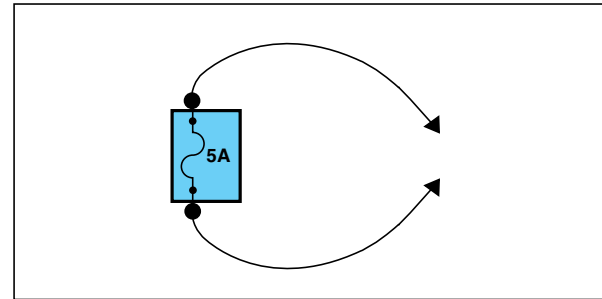

#### SHORT FINDER

A short finder is available to locate a short to ground. The short finder creates a pulsing magnetic field in the shorted circuit and shows you the location of the short through body trim or sheet metal.

#### TROUBLESHOOTING TEST

##### 1. TESTING FOR VOLTAGE

This test measures voltage in a circuit. When testing for voltage at a connector, you do not have to separate the two halves of the connector. Instead, probe the connector from the back(backprobe). Always check both sides of the connector because dirt and corrosion between its contact surfaces can cause electrical problems.

- A. Connect one lead of a test lamp or voltmeter to a ground. If you are using a voltmeter, be sure it is the voltmeter's negative test lead you have connected to ground.
- B. Connect the other lead of the test lamp or voltmeter to a selected test point(connector or terminal).
- C. If the test lamp glows, there is voltage present. If you are using a voltmeter, note the voltage reading. A loss of more than 1 volt from specification indicates a problem.

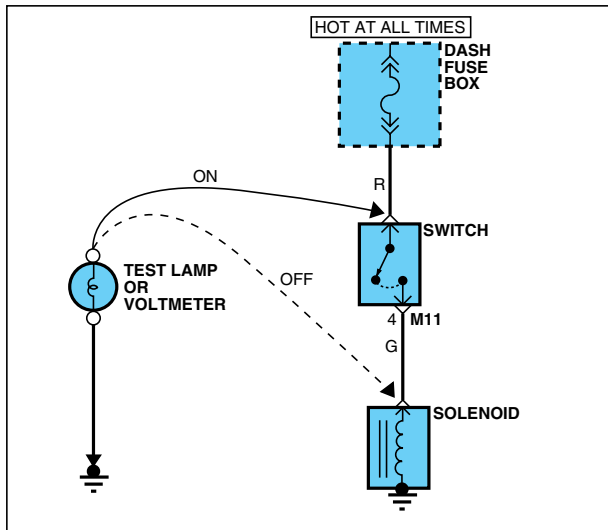

**2. TESTING FOR CONTINUITY**

- A. Disconnect the battery negative terminal.
- B. Connect one lead of a self-powered test lamp or ohmmeter to one end of the part of the circuit you wish to test. If you are using an ohmmeter, hold the leads together and adjust the ohmmeter to read zero ohms.
- C. Connect the other lead to the other end.
- D. If the self-power test lamp glows, there is continuity. If you are using an ohmmeter, low or zero resistance means good continuity.

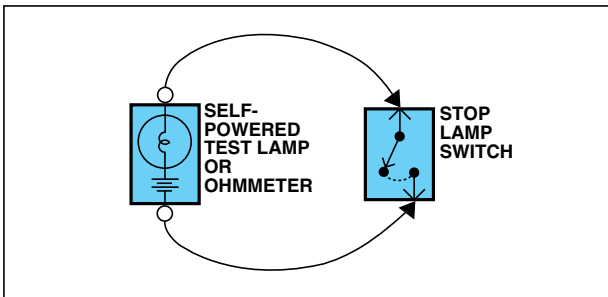

**3. TESTING FOR SHORT TO GROUND**

- A. Disconnect the battery negative terminal.
- B. Connect one lead of a self-powered test lamp or an ohmmeter to the fuse terminal on the load side.
- C. Connect the other lead to a ground.
- D. Beginning near the fuse block move the harness from side to side. Continue this procedure (about six inches apart) while watching the self-powered test lamp or ohmmeter.
- E. When the self-powered test lamp glows, or ohmmeter registers, there is a short to a ground in the wiring near that point.

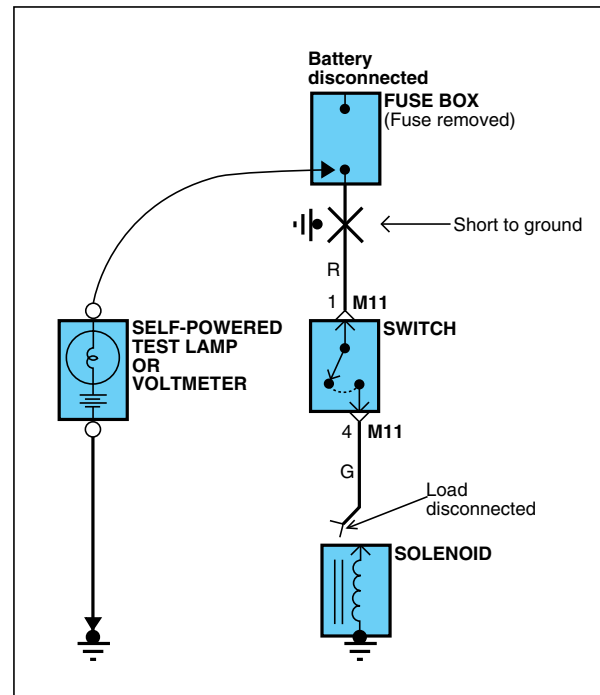

# TROUBLESHOOTING INSTRUCTIONS

## Troubleshooting Instructions (4)

GI-11

### 4. TESTING FOR A SHORT WITH A SHORT FINDER

- Remove the blown fuse. Leave the battery connected.
- Connect the short finder across the fuse terminals.
- Close all switches in series in the circuit that is being testing.
- Turn on the short circuit locator. It sends pulses of current to the short. This creates a pulsing magnetic field around the wiring between the fuse box and the short.
- Beginning at the fuse box, slowly move the short finder along the circuit wiring. The meter will show current pulses through sheet metal and body trim. As long as the meter is between the fuse and the short, the needle will move with each current pulse. Once the meter is moved past the point of the short, the needle will stop moving. Check around this area to locate the cause of the short circuit.

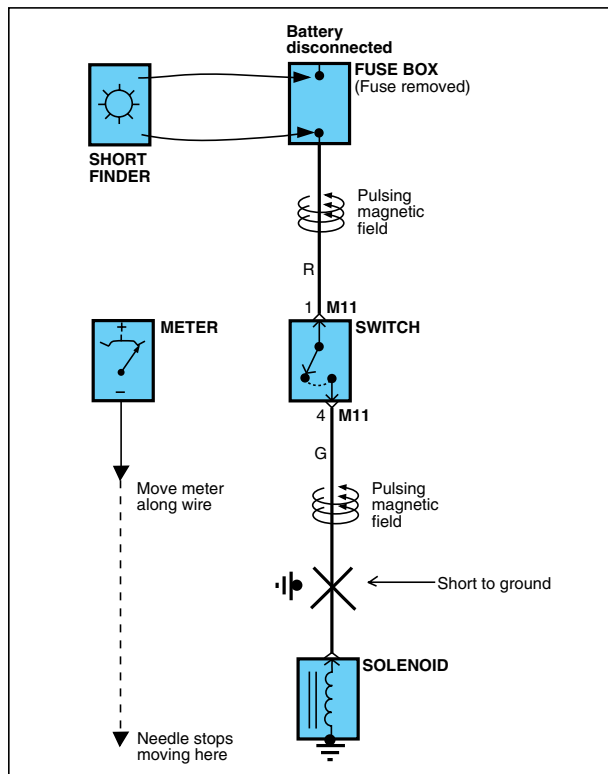

### 5. TESTING FOR VOLTAGE DROP

This test checks for voltage drop along a wire, or through a connection or switch.

- Connect the positive lead of a voltmeter to the end of the wire (or to the side of the connector or switch) closest to the battery.
- Connect the negative lead to the other end of the wire (or the other side of the connector or switch).
- Operate the circuit.
- The voltmeter will show the difference in voltage between the two points. A difference, or drop of more than 0.1 volts (50mV in 5V circuits), may indicate a problem. Check the circuit for loose or dirty connections.

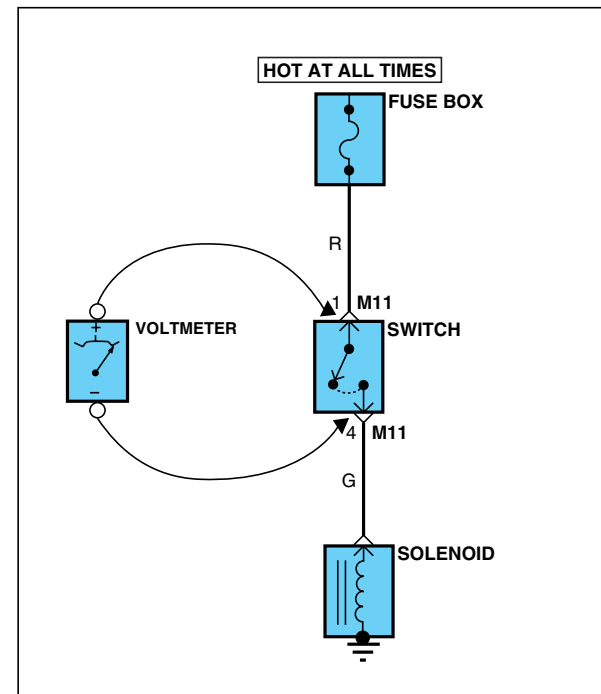

Fuse & Relay Information (1)

SD100-1

I/P JUNCTION BOX

< LHD >

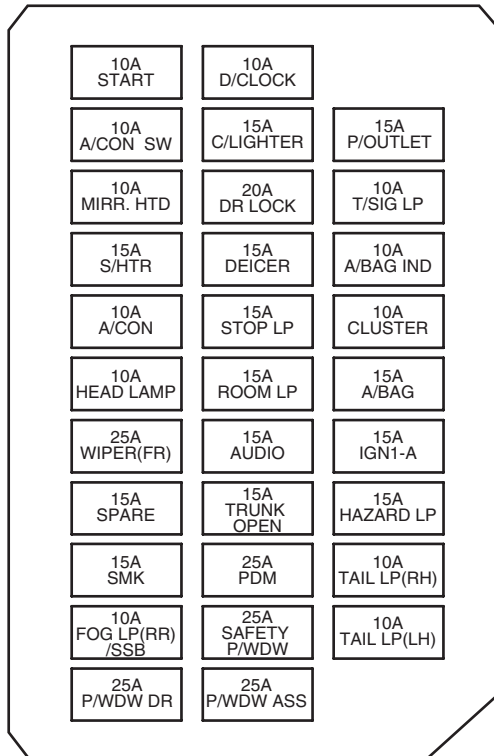

< RHD >

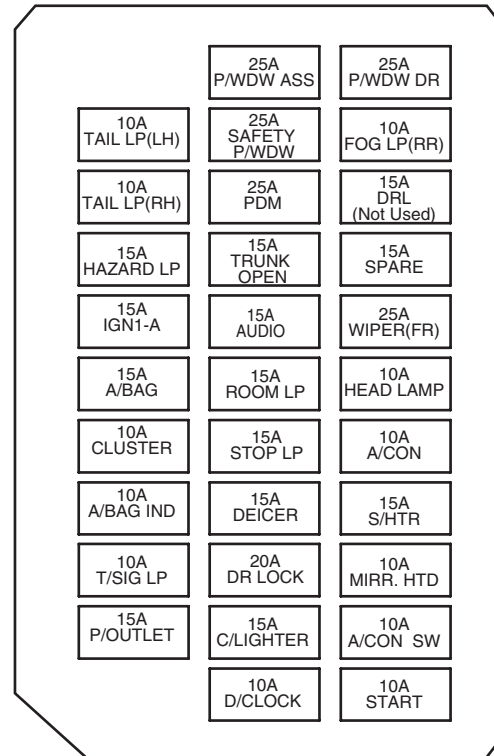

< REAR >

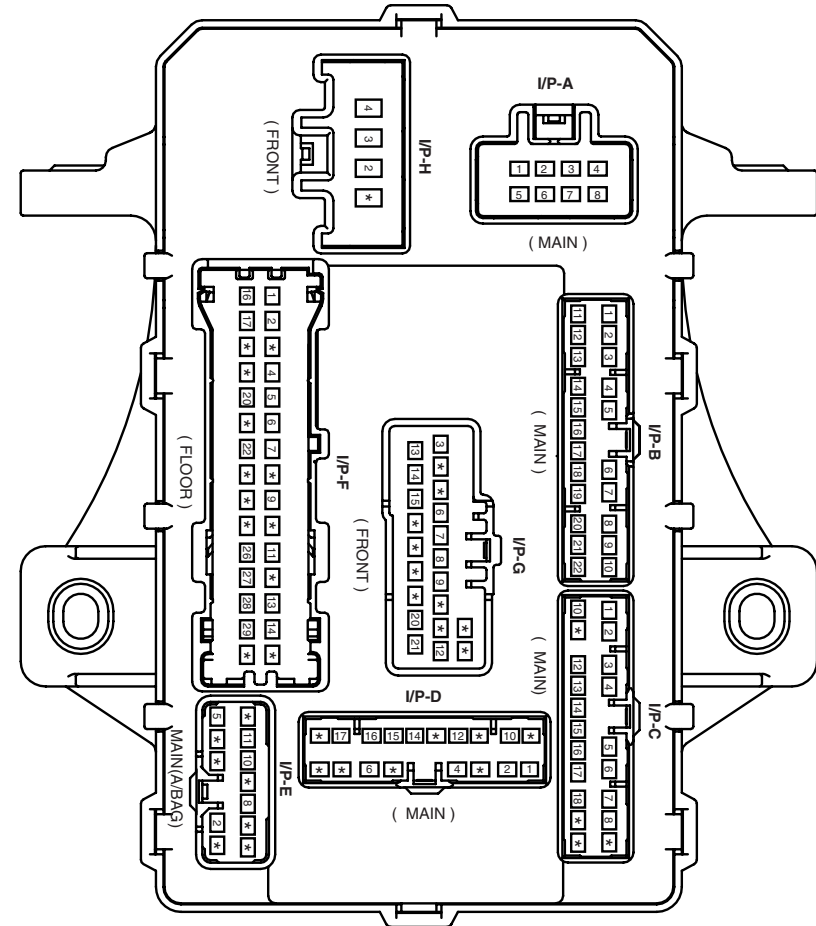

✘ USE THE DESIGNATED FUSE ONLY

## FUSE & RELAY INFORMATION

### Fuse & Relay Information (2)

SD100-2

#### CIRCUIT

FUSE	(A)	Circuit Protected	
START	10A	Transaxle Range Switch, Ignition Lock Switch	
A/CON SW	10A	A/C Control Module(Auto)	
MIRR. HTD	10A	Driver/ Passenger Power Outside Mirror (Defogger), A/C Control Module (Rear Defogger SW), ECM, PCM	
S/HTR	15A	Front Seat Warmer LH/RH	
A/CON	10A	E/R Fuse & Relay Box (Blower Relay), BCM, Incar Temperature Sensor(Auto), Sunroof Control Module PDM, A/C Control Module	
HEAD LAMP	10A	E/R Fuse & Relay Box ( H/LP (HI/LO) Relay)	
WIPER(FR)	25A	Multifunction Switch (Wiper & Washer SW), E/R Fuse & Relay Box (Wiper Relay), Front Wiper Motor	
SMK	15A	Smart Key Control Module, PDM	
FOG LP(RR)/SSB	10A	Start Stop Button Switch, FOB Holder, ICM Relay Box(Rear Fog Relay)	
P/WDW DR	25A	Safety/ Power Window Main Switch, Rear Power Window Switch LH, Safety Power Window Module	
D/CLOCK	10A	Audio, BCM, Smart Key Control Module, PDM, Clock, Power Outside Mirror Switch	
C/LIGHTER	15A	Cigarette Lighter	
DR LOCK	20A	Sunroof Control Module, ICM Relay Box(Door Lock/Unlock Relay)	
DEICER	15A	ICM Relay Box(Front Deicer Relay)	
STOP LP	15A	Stop Lamp Switch, Sport Mode Switch	
POWER CONNECTOR	ROOM LP	15A	Trunk Room Lamp, BCM, Clock, Instrument Cluster, Data Link Connector, A/C Control Module, Rear Parking Assist Buzzer, Ignition Key Ill. & Door Warning Switch, Room Lamp, RF Receiver, Vanity Lamp LH/RH, Map Lamp
	AUDIO	15A	Audio
TRUNK OPEN	15A	Trunk Open Relay	
PDM	25A	PDM	
SAFETY P/WDW	25A	Safety Power Window Module	
P/WDW ASS	25A	Power Window Main Switch, Passenger Power Window Switch, Rear Power Window Switch RH Safety Power Window Main Switch	
P/OUTLET	15A	Power Outlet	
T/SIG LP	10A	Hazard Switch	
A/BAG IND	10A	Instrument Cluster(IND.)	
CLUSTER	10A	Instrument Cluster (IND.), BCM, Electro Chromic Mirror, Rheostat, Steering Angle Sensor	
A/BAG	15A	SRS Control Module	
IGN 1-A	15A	PDM, Smart Key Control Module	
HAZARD LP	15A	ICM Relay Box (Hazard Relay), Hazard Switch	
TAIL LP(RH)	10A	Rear Combination Lamp (In/Out) RH, Head Lamp RH, Shunt Connector, Passenger Power Window Switch License Lamp RH(4DR), Illuminations	
TAIL LP(LH)	10A	Head Lamp LH, Rear Combination Lamp (In/Out) LH, Power Window Main Switch, Safety Power Window Main Switch License Lamp(2DR), License Lamp LH(4DR)	

✘ USE THE DESIGNATED FUSE ONLY

# FUSE & RELAY INFORMATION

## Fuse & Relay Information (3)

SD100-3

### E/R FUSE & RELAY BOX

#### LAYOUT

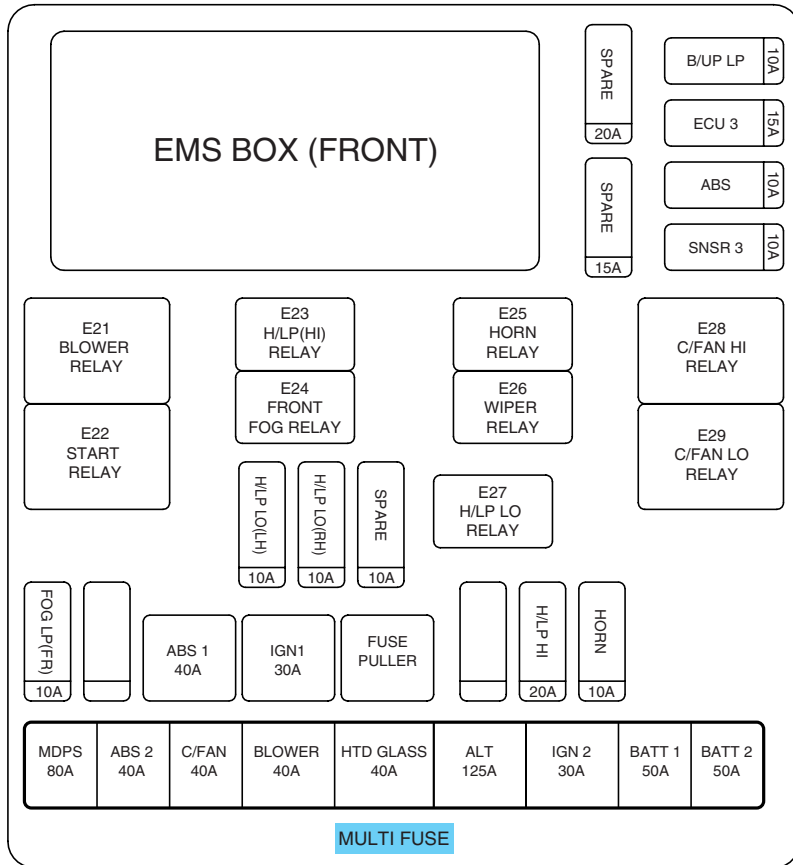

MULTI FUSE

#### EMS BOX (FRONT)

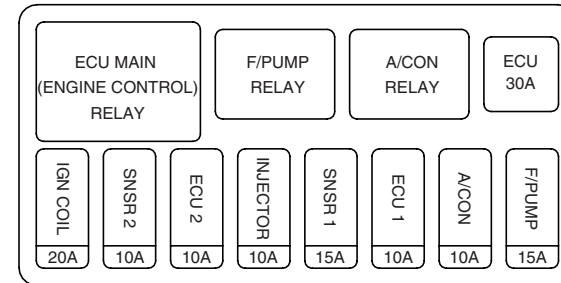

#### EMS BOX (REAR)

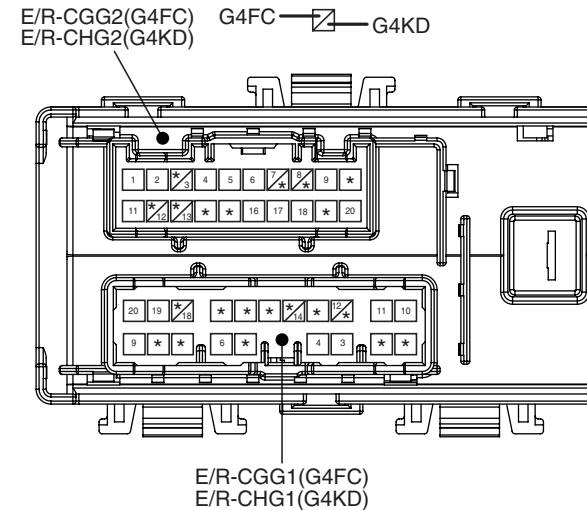

⊠ USE THE DESIGNATED FUSE ONLY

# FUSE & RELAY INFORMATION

## Fuse & Relay Information (4)

SD100-4

### CIRCUIT

	Description	(A)	Circuit Protected
MULTI FUSE	ALT	125A	Generator, Fuse (MDPS, HTD GLASS, C/FAN, ABS 2, BLOWER, IGN 1, FOG LP(FR), ABS 1)
	MDPS	80A	EPS Control Module
	ABS 2	40A	ESP Control Module, ABS Control Module
	C/FAN	40A	C/Fan LO/HI Relay
	BLOWER	40A	Blower Relay
	HTD GLASS	40A	Rear Defogger Relay
	IGN 2	30A	Ignition Switch, Start Relay, Button Relay Box (ESCL Relay)
	BATT 1	50A	I/P Junction Box (Fuse (TAIL LAMP(LH/RH), P/WDW DR, P/WDW ASS, SAFETY P/WDW, FOG LP(RR)/SSB, SMK, PDM), Tail Lamp Relay, Power Window Relay)
BATT 2	50A	I/P Junction Box (Power Connector(AUDIO, ROOM LP LAMP), FUSE(STOP LP, DEICER, HAZARD LP, DR LOCK, TRUNK OPEN))	
FUSE	ABS 1	40A	ESP Control Module, ABS Control Module
	IGN 1	30A	Ignition Switch, Button Relay Box (ESCL Relay (IGN1/ACC))
	ECU	30A	Engine Control Relay
	FOG LP(FR)	10A	Multipurpose Check Connector, Front Fog Relay
	H/LP HI	20A	H/LP (HI) Relay,
	HORN	10A	Horn Relay
	H/LP LO(LH)	10A	Head Lamp LH, Head Lamp Leveling Switch, Head Lamp Leveling Actuator LH
	H/LP LO(RH)	10A	Head Lamp RH, Head Lamp Leveling Actuator RH
	SPARE	10A	-
	SNSR 3	10A	ECM, PCM, Vehicle Speed Sensor, Pulse Generator 'A', Stop Lamp Switch, Multifunction Switch
	ABS	10A	Multipurpose Check Connector, ESP Control Module, ABS Control Module
	ECU 3	15A	Ignition Coil (#1~#4), Condenser, PCM
	B/UP LP	10A	Transaxle Range Switch, Pulse Generator 'B', Back Up Lamp Switch
	SPARE	15A	-
	SPARE	20A	-
	IGN COIL	20A	Condenser(G4KD), Ignition Coil #1~4(G4KD)
	SNSR 2	10A	Oil Control Valve, Camshaft Position Sensor, F/PUMP Relay, C/FAN HI/LO Relay, Canister Purge Solenoid Valve(G4FC), Immobilizer Module
	ECU 2	10A	PCM(G4KD), Purge Control Solenoid Valve(G4KD), Oxygen Sensor(Down)(G4KD)
	INJECTOR	10A	A/CON Relay, Crankshaft Position Sensor(G4KD), Oxygen Sensor(UP)(G4KD), Injector #1~4,
	SNSR 1	15A	PCM(G4KD), Oxygen Sensor(UP)(G4FC), Oxygen Sensor(Down)(G4FC), Idle Speed Control Actuator(G4FC)
ECU 1	10A	ECM, PCM	
A/CON	10A	A/CON Relay	
F/PUMP	15A	F/PUMP Relay	

**※ USE THE DESIGNATED FUSE ONLY**

# FUSE & RELAY INFORMATION

## Fuse & Relay Information (5)

SD100-5

### ICM RELAY BOX

#### LAYOUT

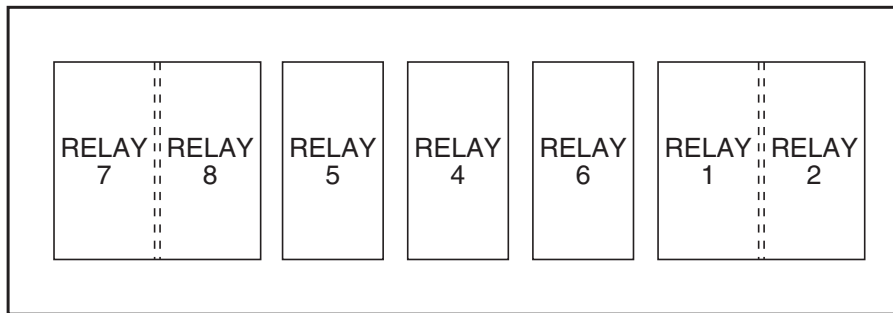

RELAY NO.	RELAY NAME
1	TURN RH RELAY (NOT USED)
2	TURN LH RELAY (NOT USED)
4	REAR FOG RELAY
5	FRONT DEICER RELAY
6	HAZARD RELAY
7	DOOR LOCK RELAY
8	DOOR UNLOCK RELAY

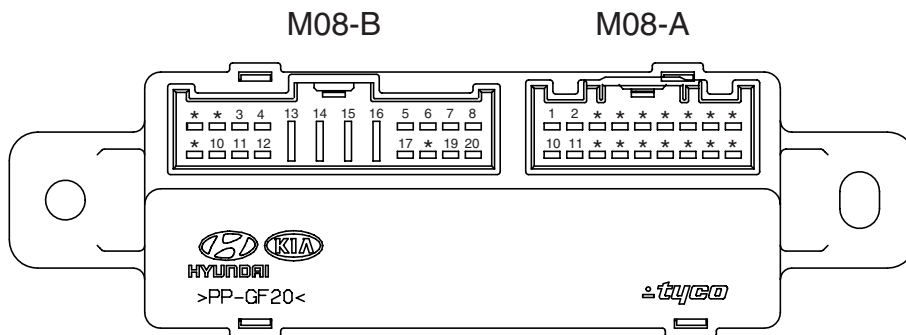



**FUSE & RELAY INFORMATION**

**Fuse & Relay Information (6)**

**SD100-6**

**MEMO**

**POWER DISTRIBUTION**

E282C25B

**Power Distribution (1)**

**SD110-1**

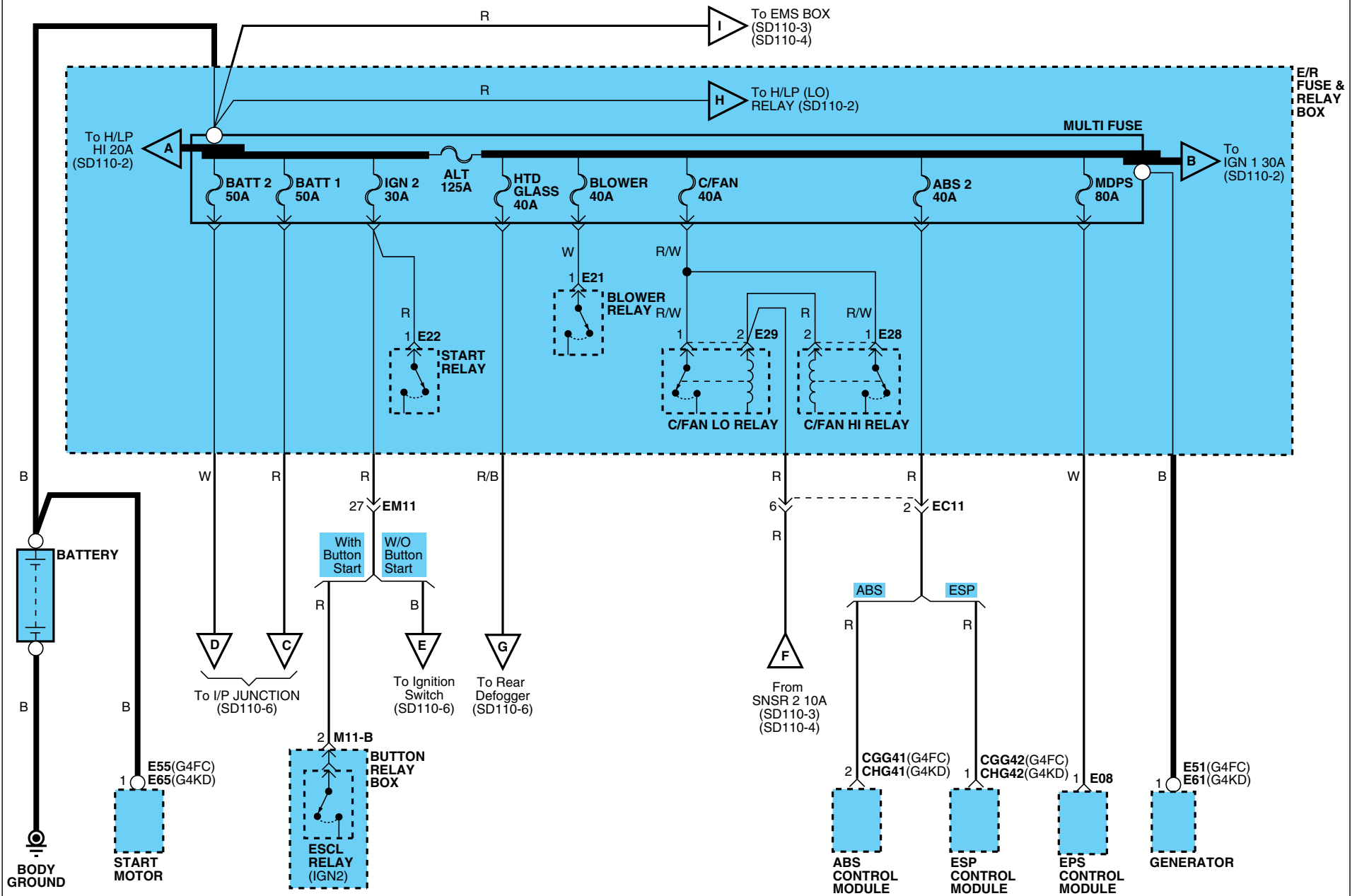

# POWER DISTRIBUTION

## Power Distribution (2)

SD110-2

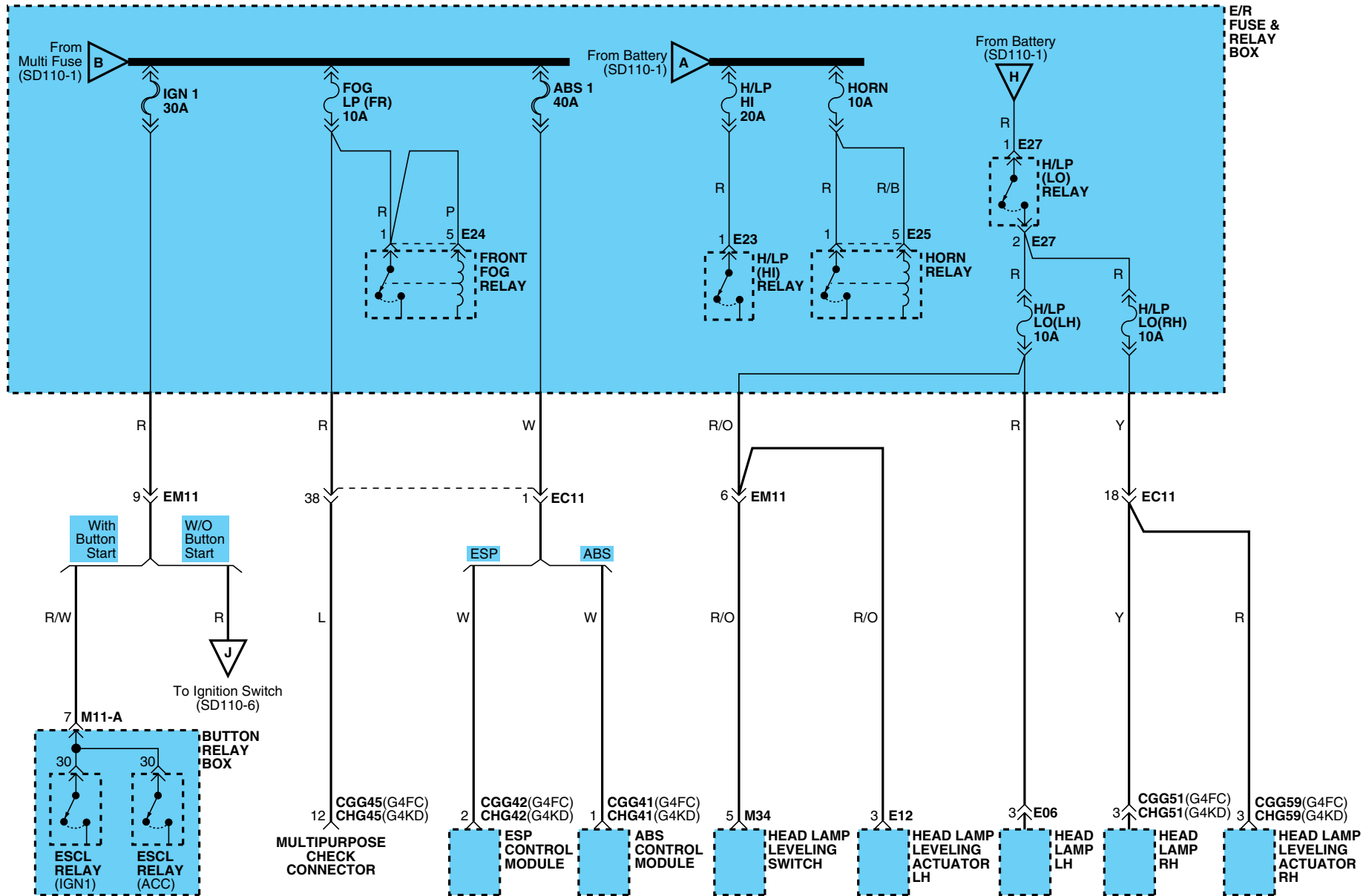

# POWER DISTRIBUTION

## Power Distribution (3)

SD110-3

### G4FC - GSL 1.6L

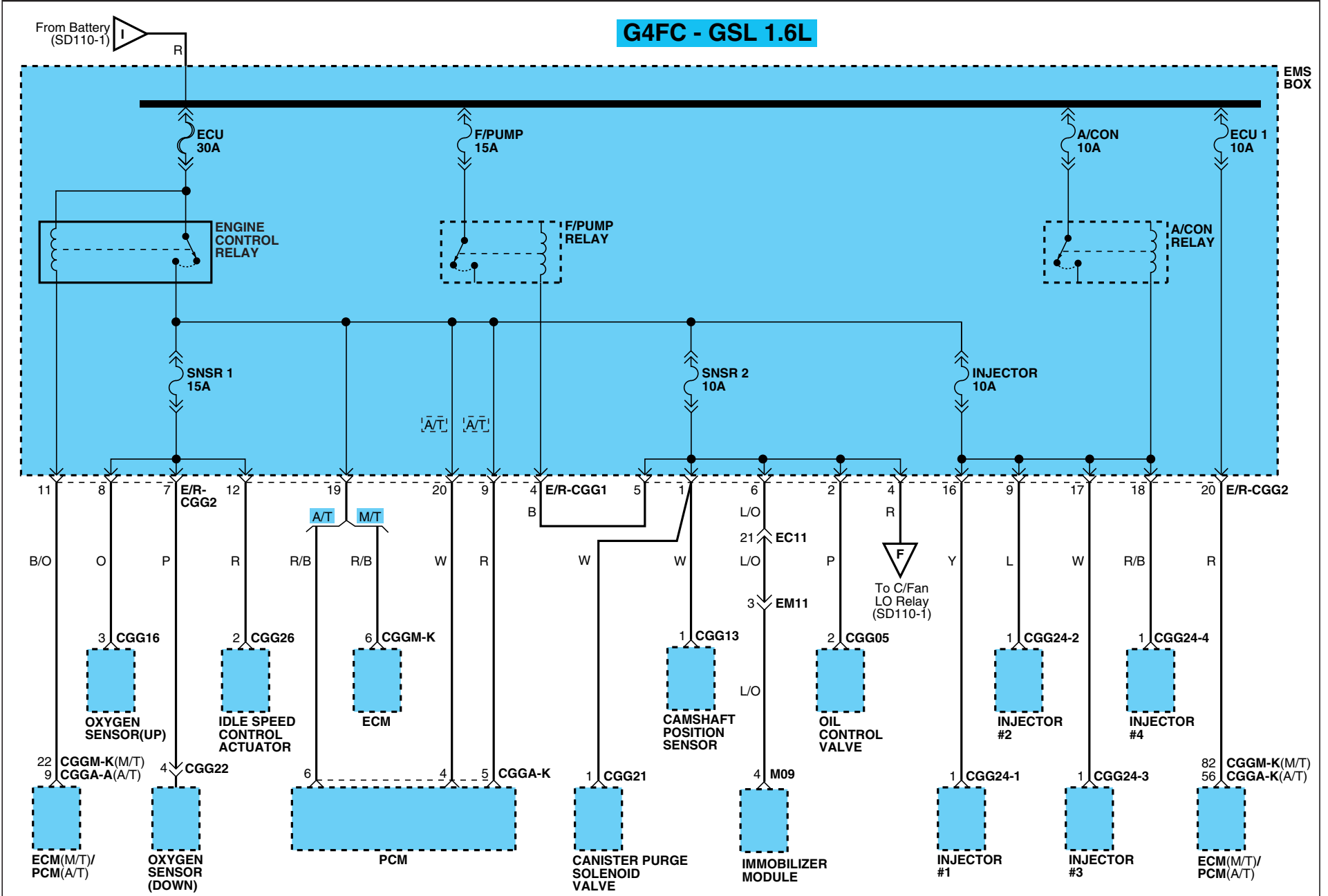

# POWER DISTRIBUTION

## Power Distribution (4)

SD110-4

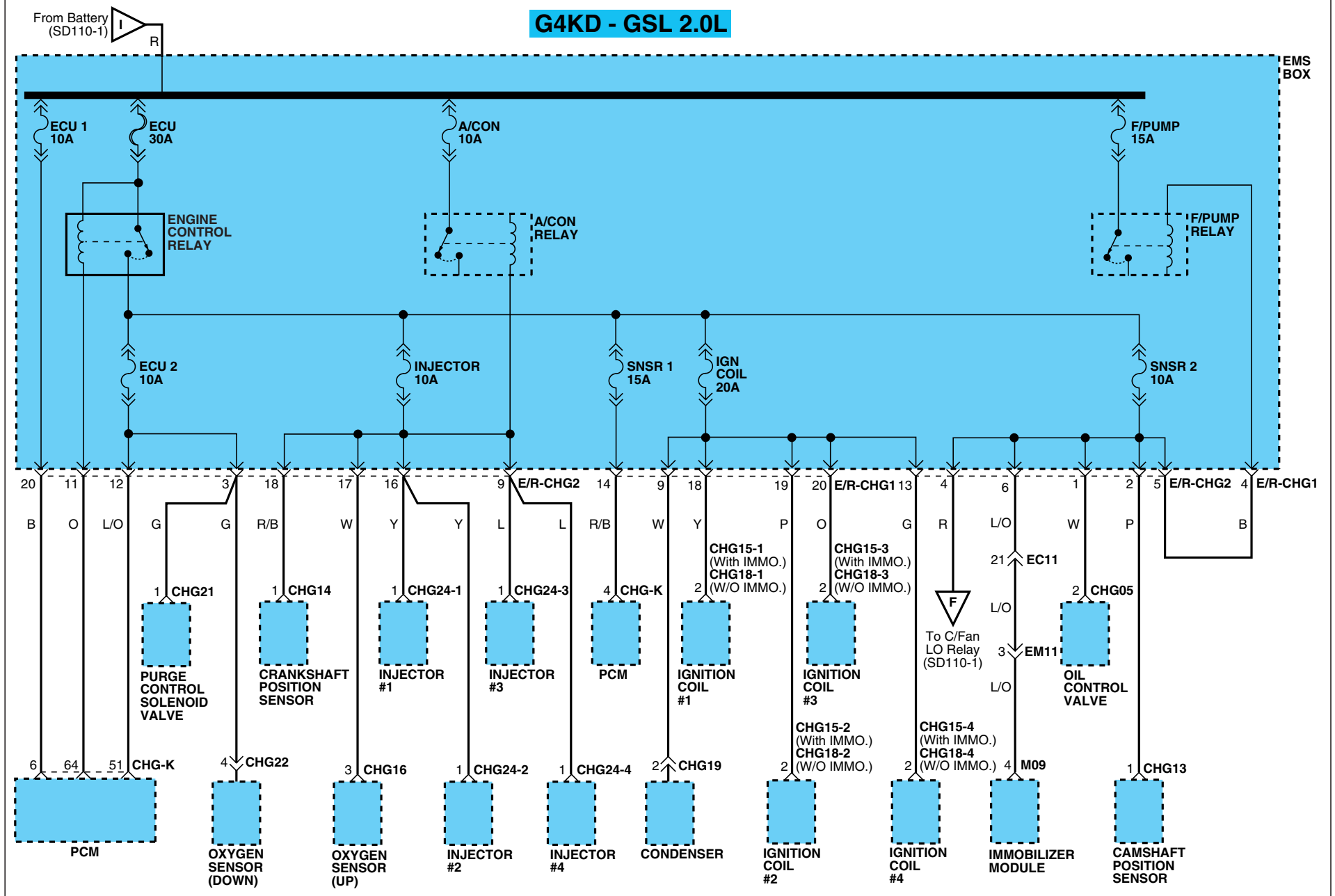

# POWER DISTRIBUTION

## Power Distribution (5)

SD110-5

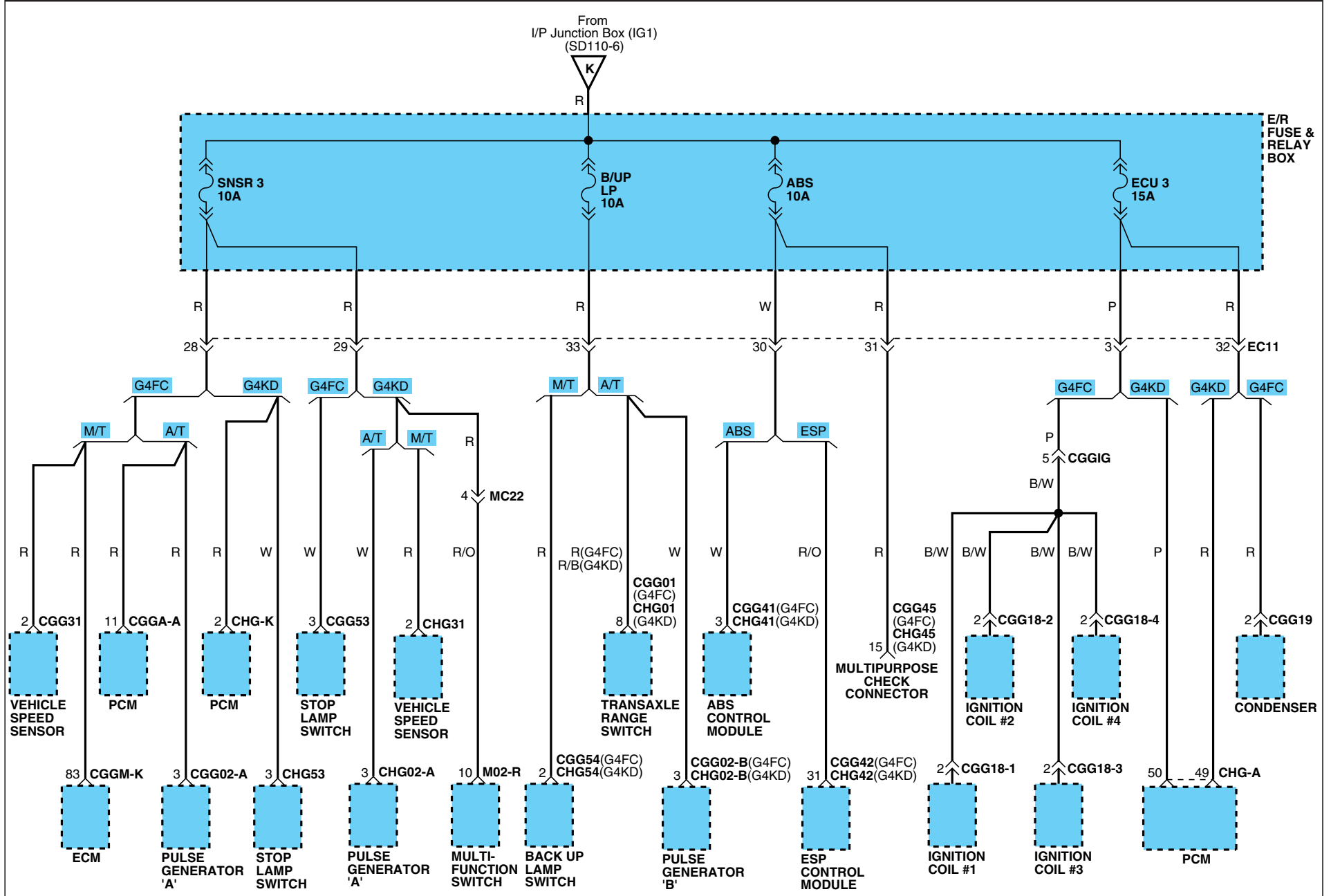

# POWER DISTRIBUTION

## Power Distribution (6)

SD110-6

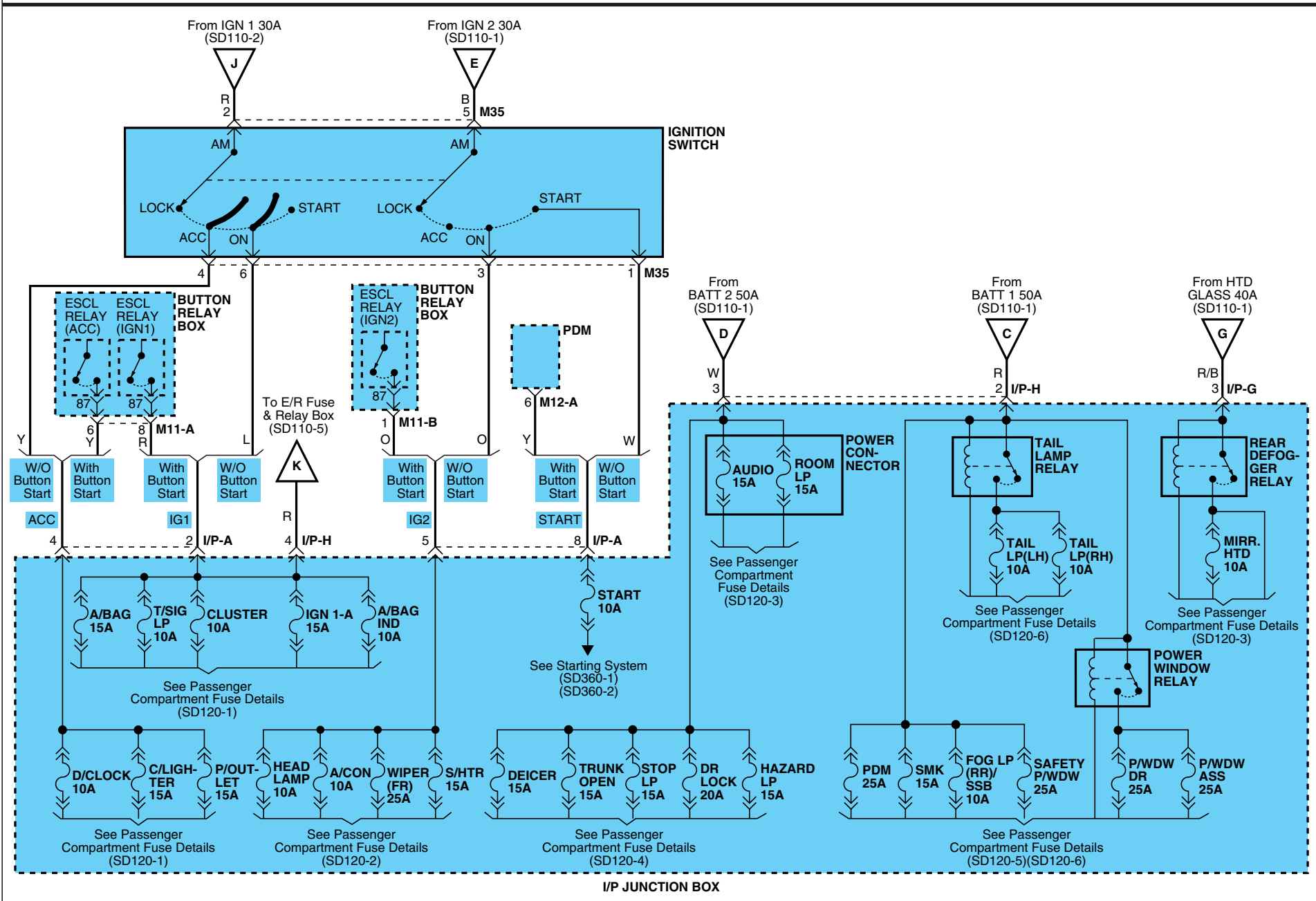

Passenger Compartment Fuse Details (1)

SD120-1

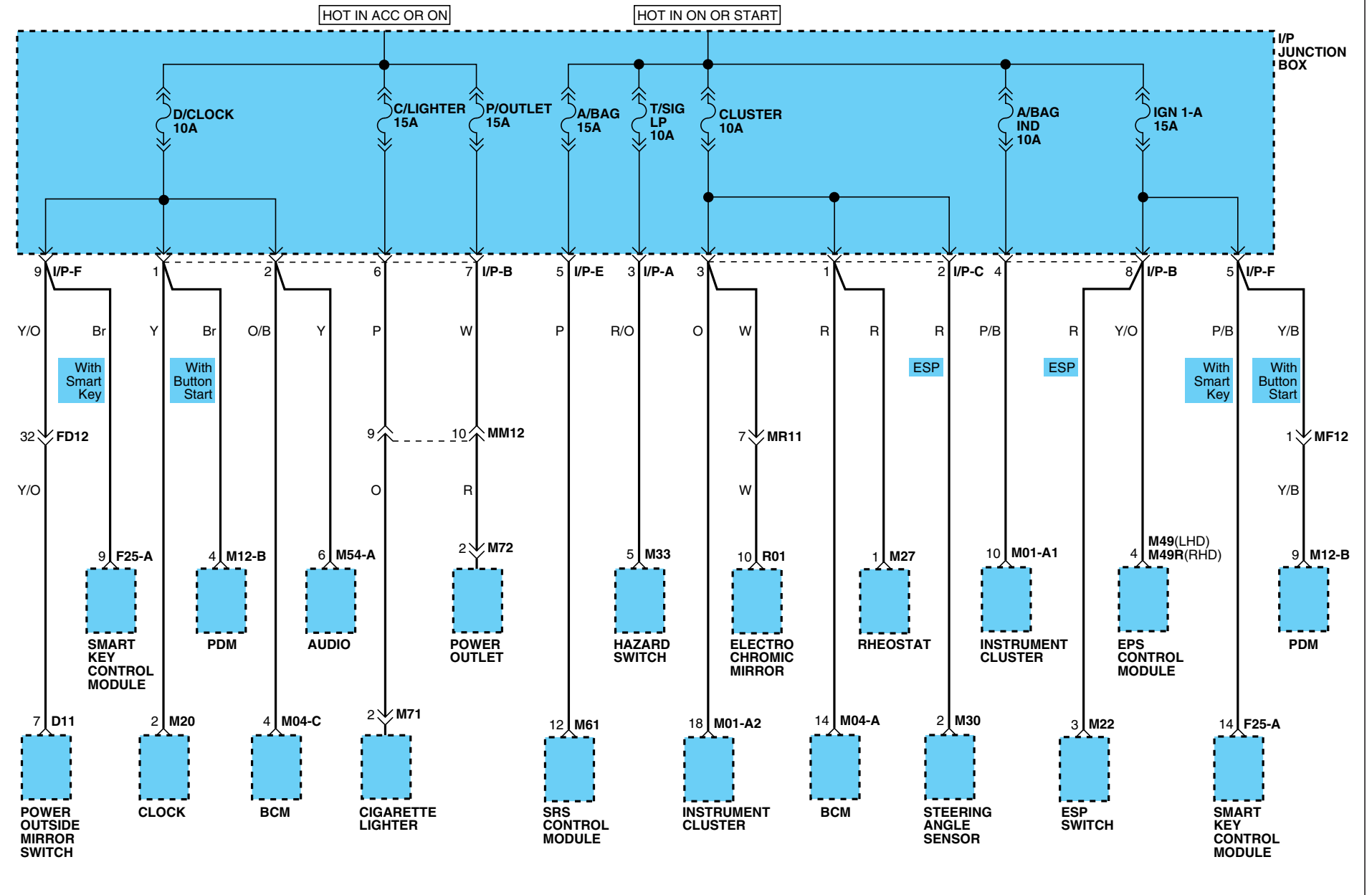



# PASSENGER COMPARTMENT FUSE DETAILS

## Passenger Compartment Fuse Details (2)

SD120-2

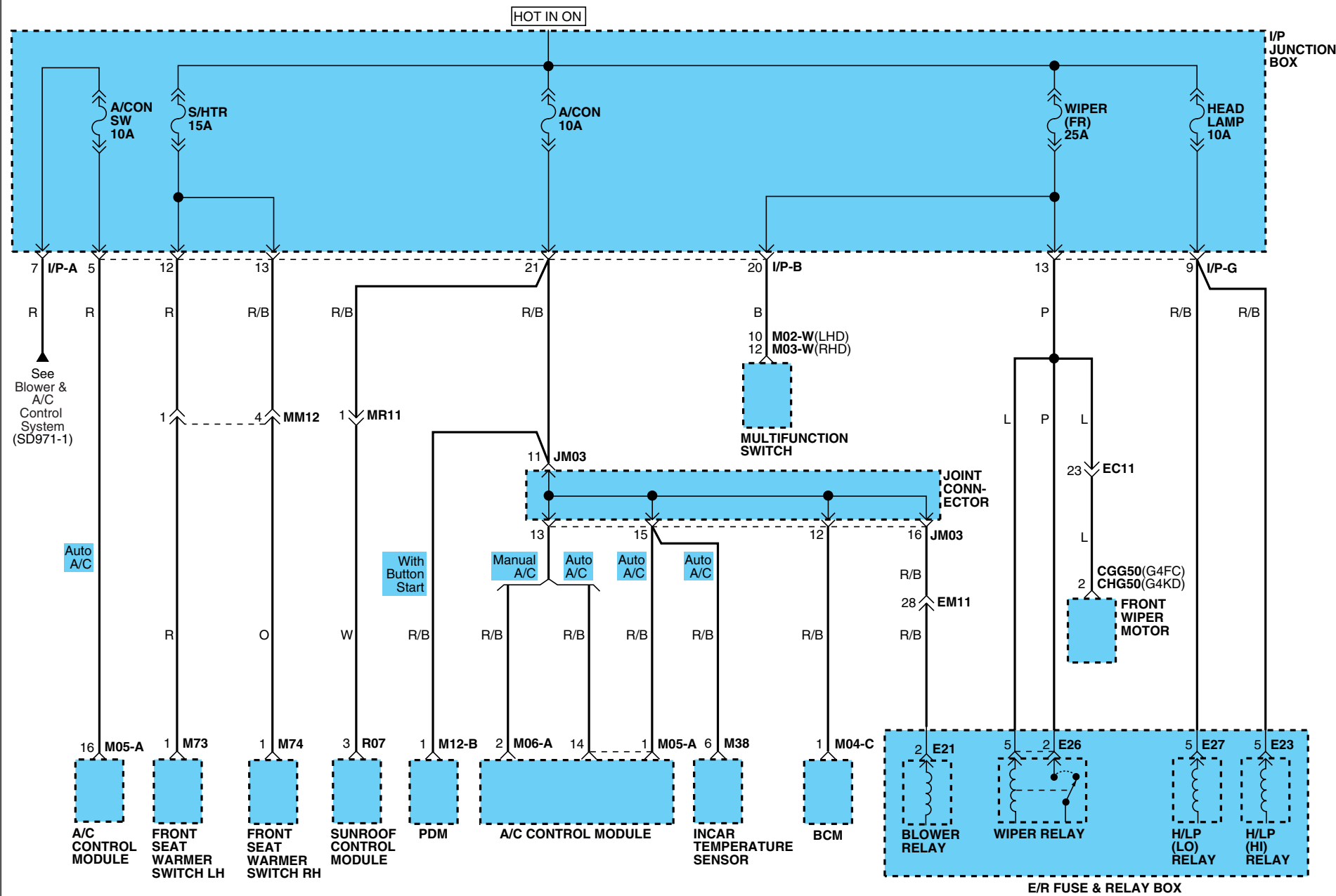



# PASSENGER COMPARTMENT FUSE DETAILS

## Passenger Compartment Fuse Details (4)

SD120-4

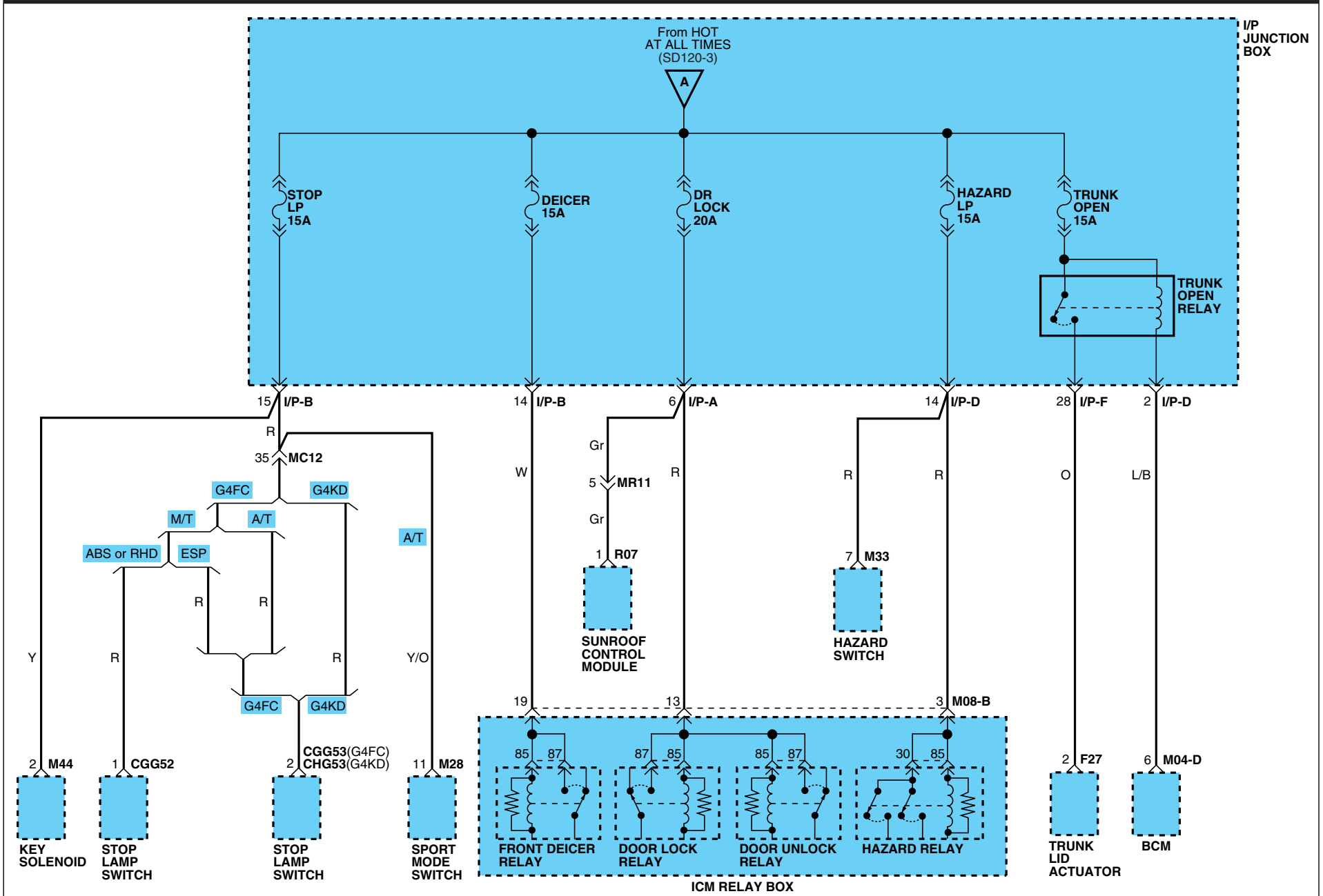

# PASSENGER COMPARTMENT FUSE DETAILS

## Passenger Compartment Fuse Details (5)

SD120-5

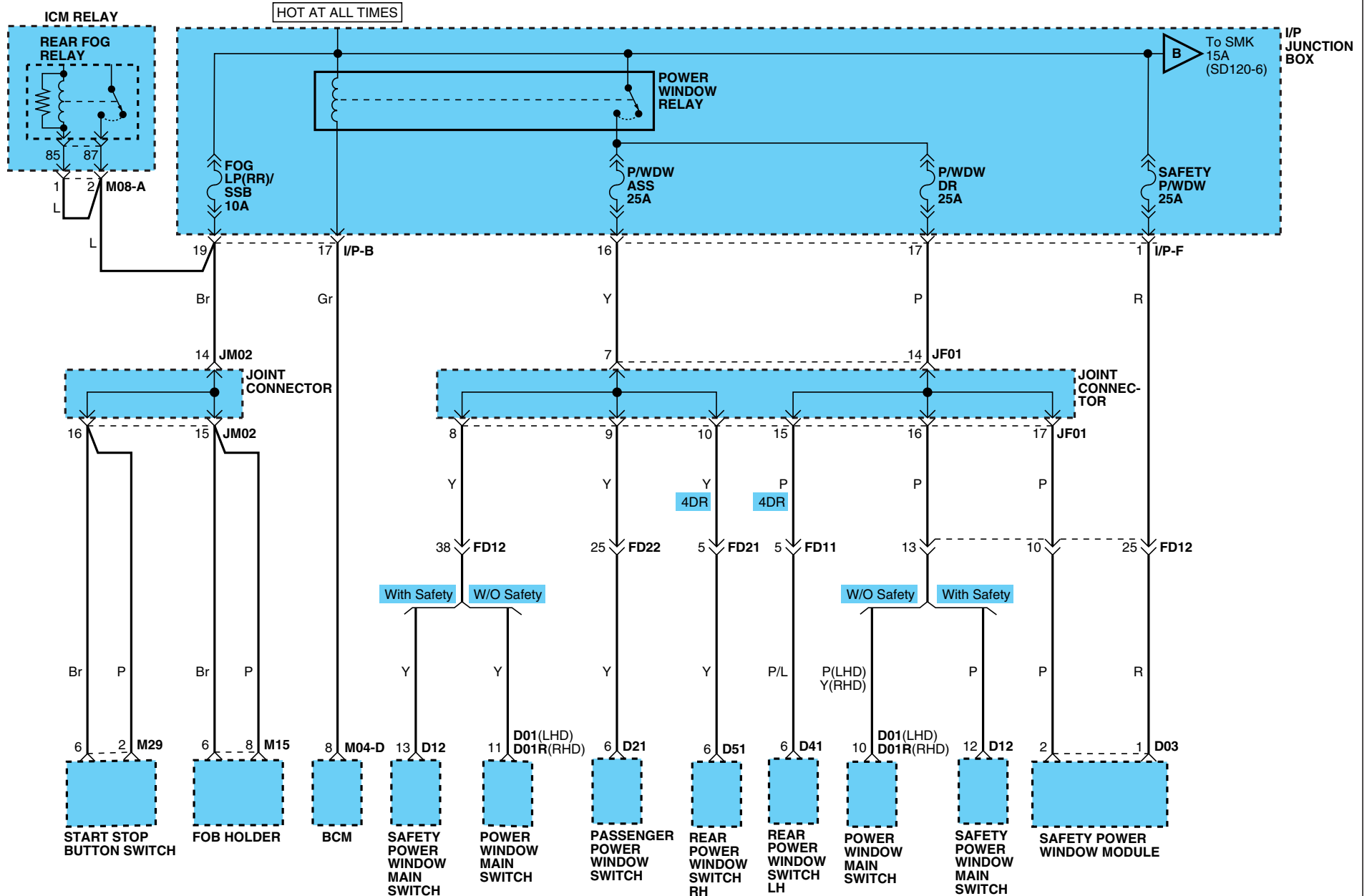



Ground Distribution (1)

SD130-1

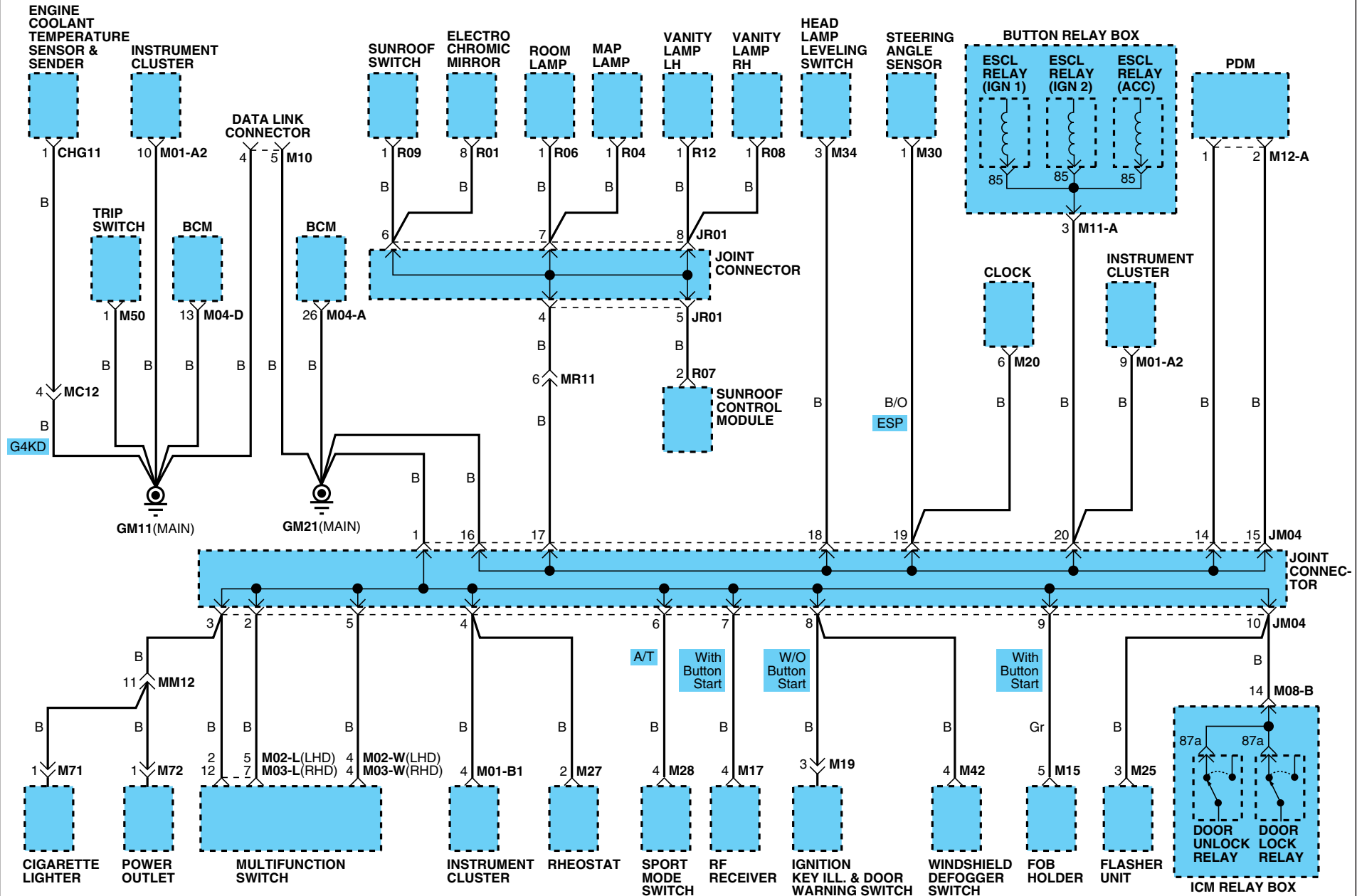

# GROUND DISTRIBUTION

## Ground Distribution (2)

SD130-2

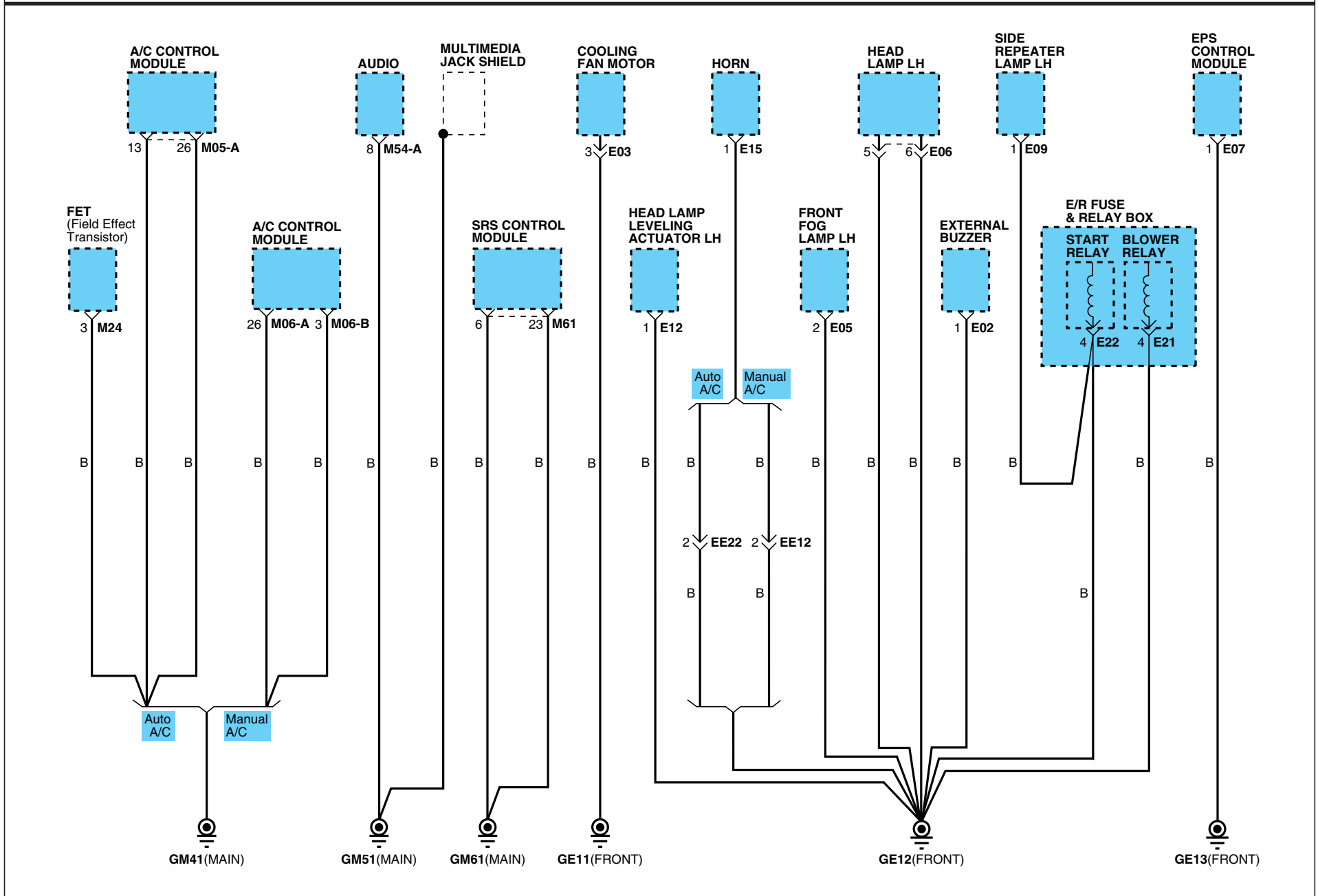

# GROUND DISTRIBUTION

## Ground Distribution (3)

SD130-3

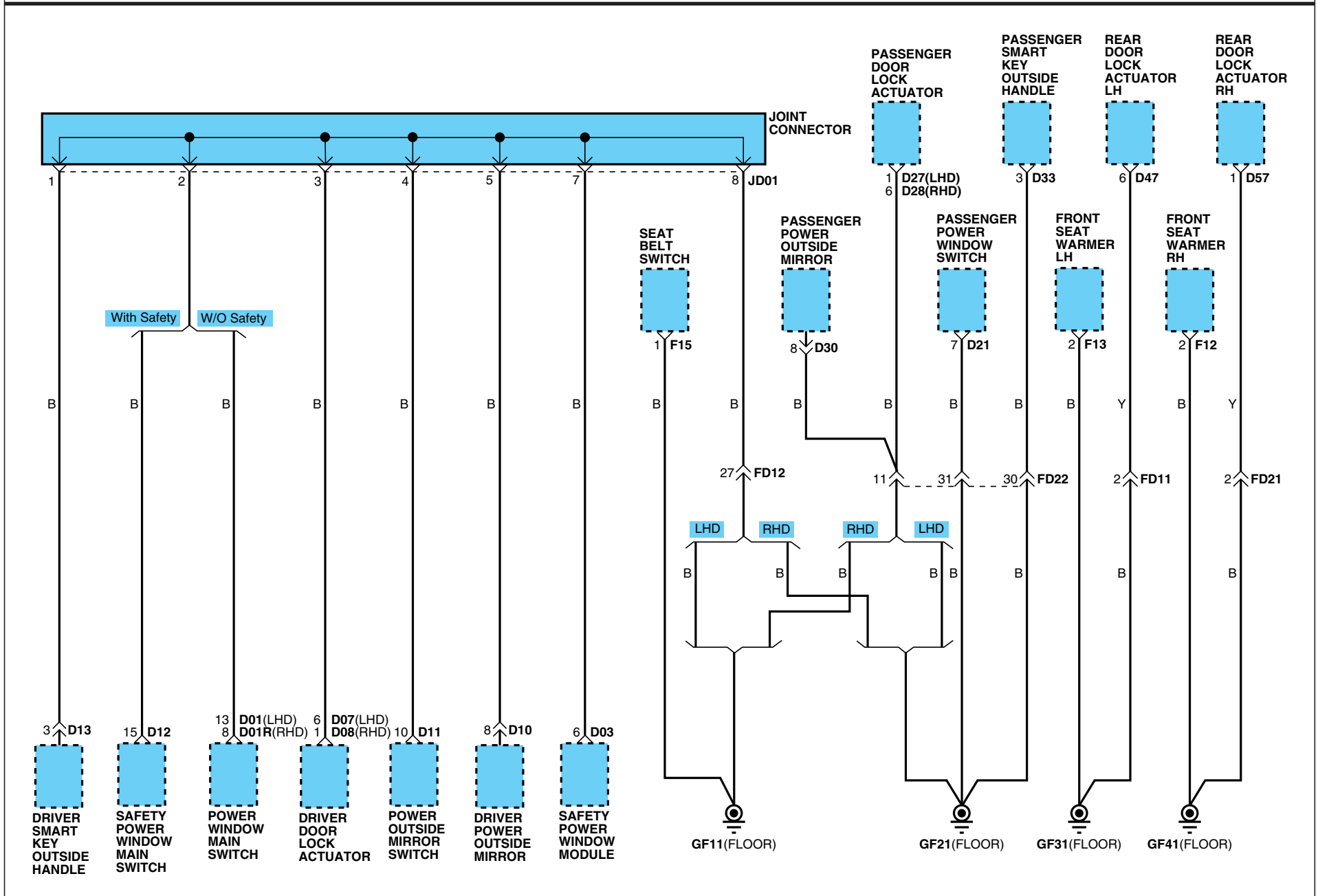



# GROUND DISTRIBUTION

## Ground Distribution (4)

SD130-4

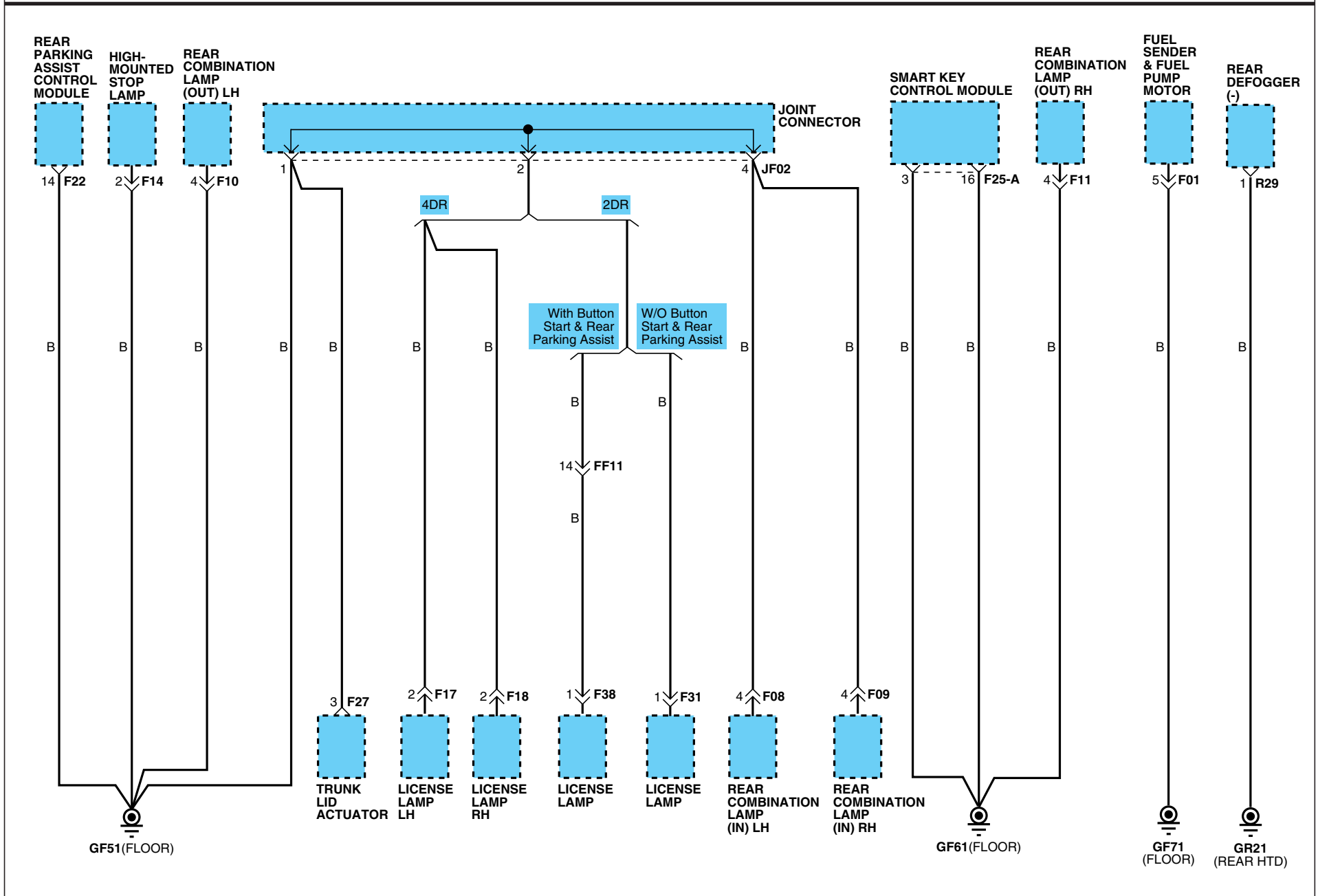

# GROUND DISTRIBUTION

## Ground Distribution (5)

SD130-5

### G4FC - GSL 1.6L

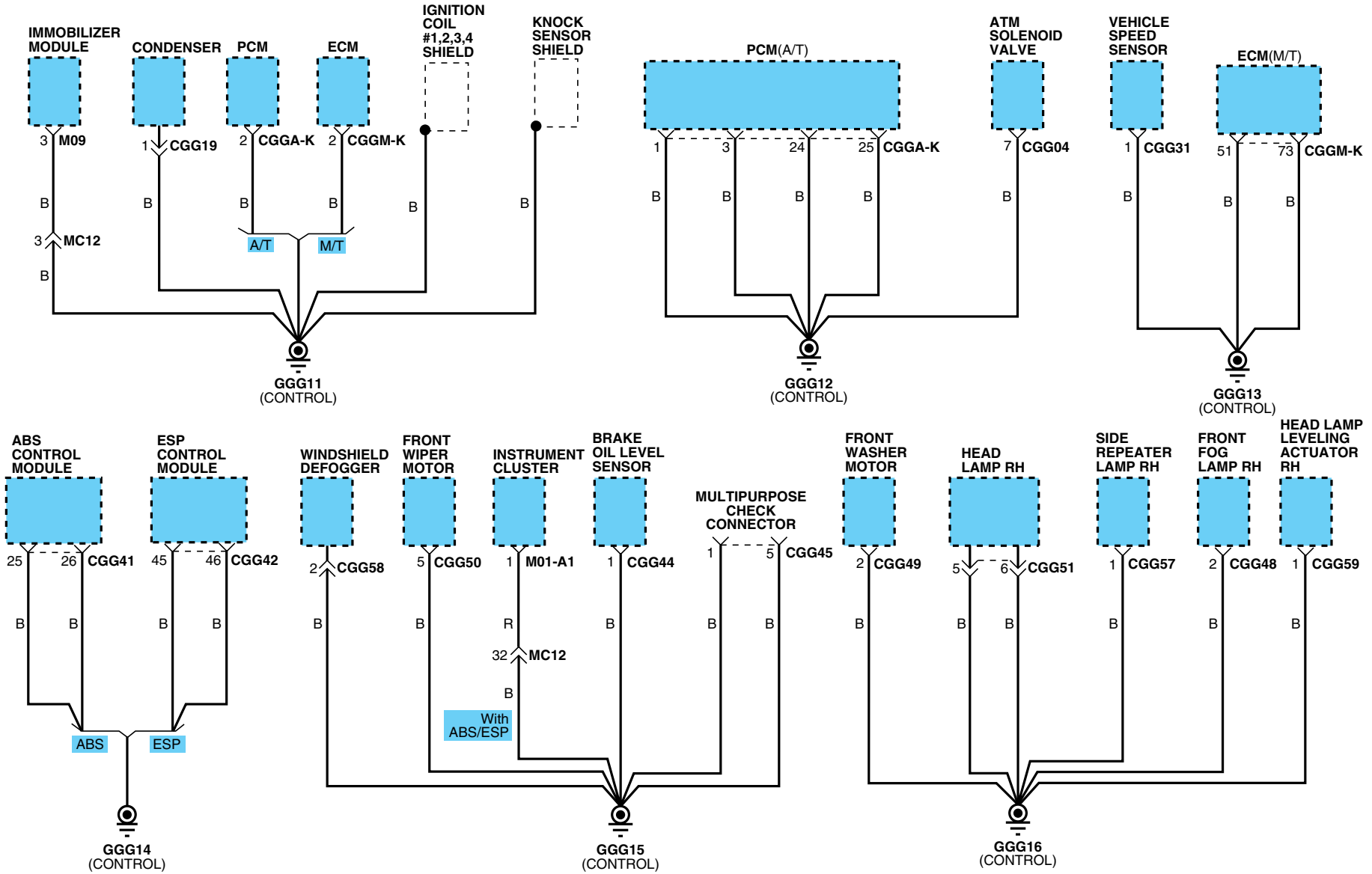

# GROUND DISTRIBUTION

## Ground Distribution (6)

SD130-6

### G4KD - GSL 2.0L

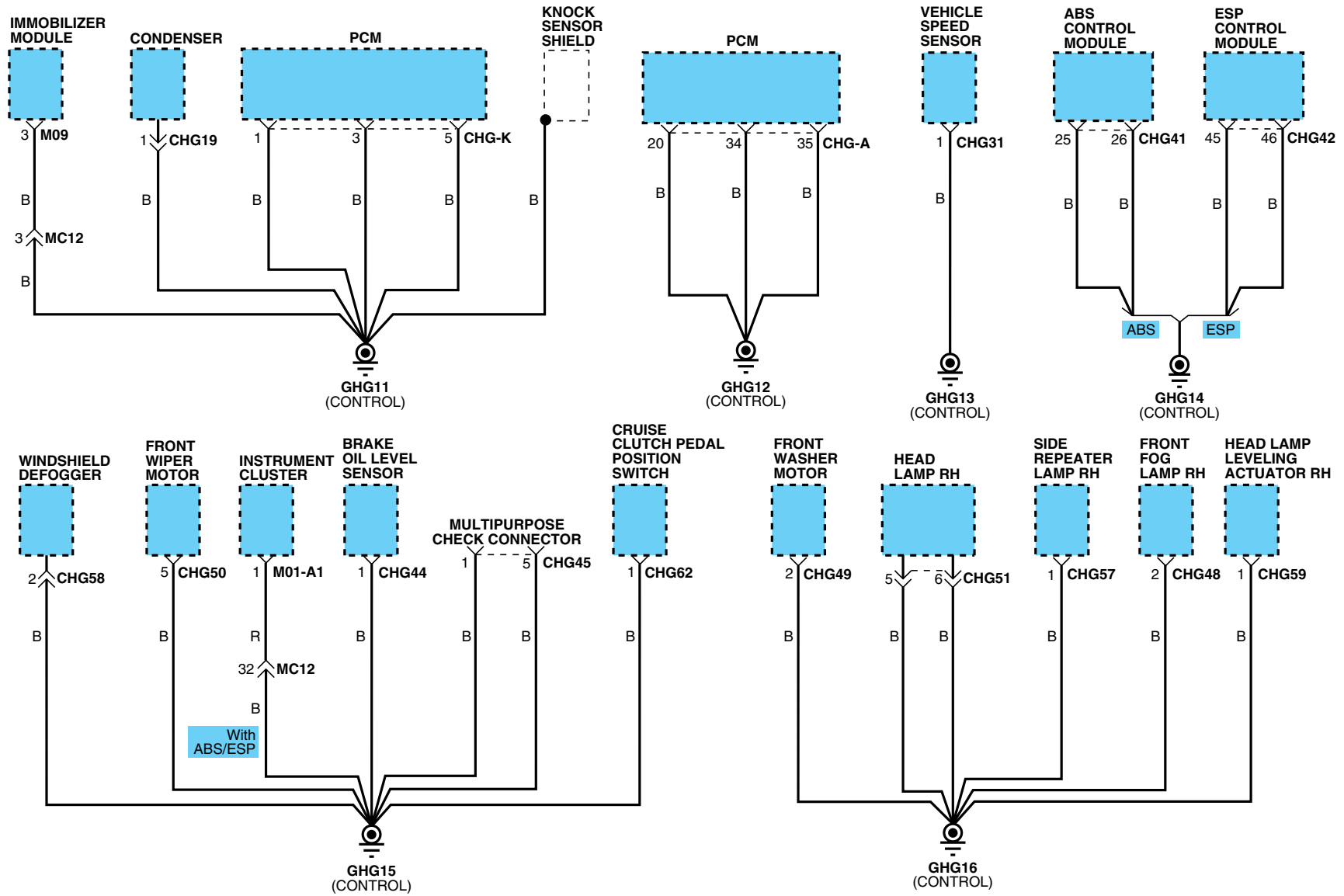

Data Link Details (1)

SD200-1

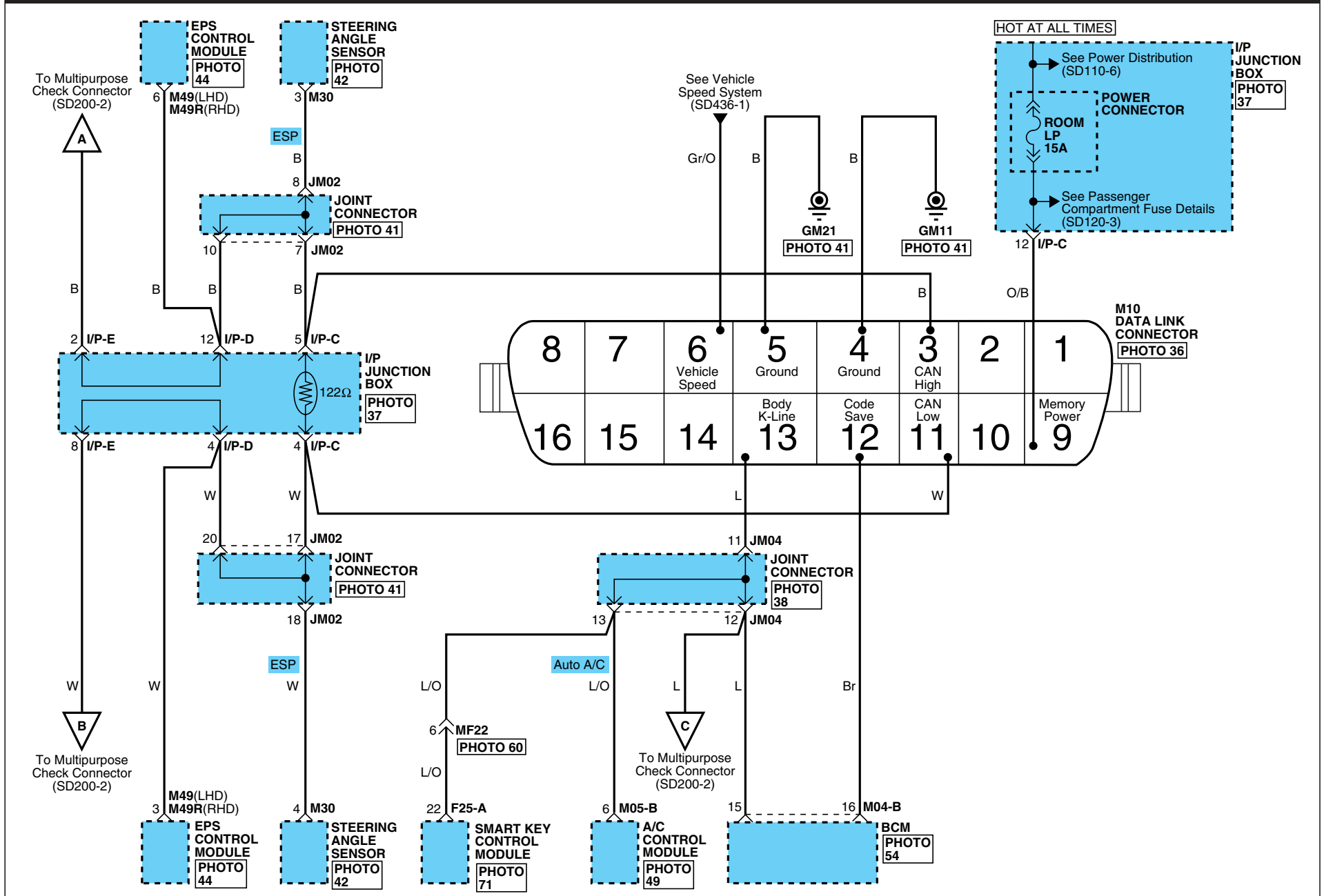

# DATA LINK DETAILS

## Data Link Details (2)

SD200-2

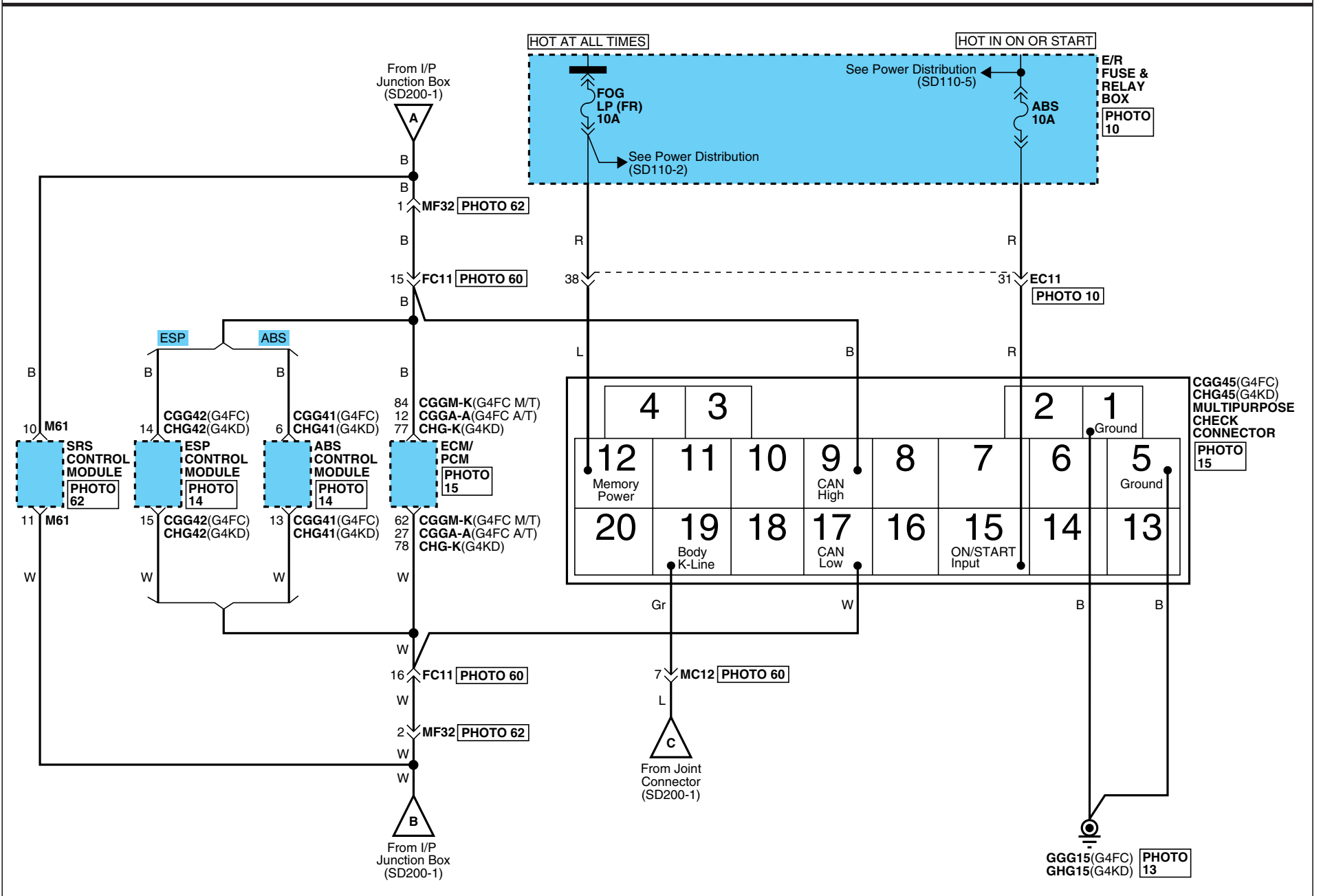

# DATA LINK DETAILS

## Data Link Details (3)

SD200-3

**CGGA-A**

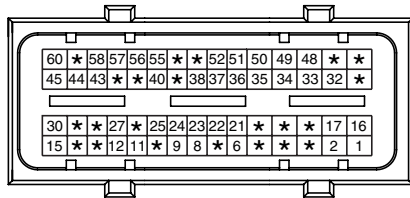

AMP\_ECU\_60F\_B

**CGGM-K**

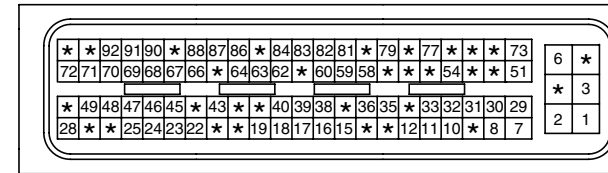

AMP\_ECU\_94F\_B

**CGG41**

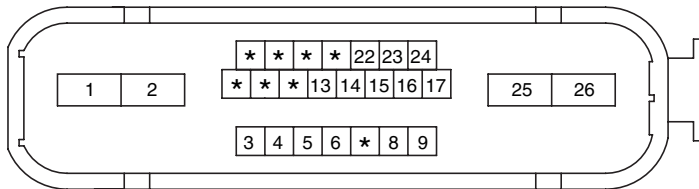

AMP\_ABS\_26F\_B

**CGG42**

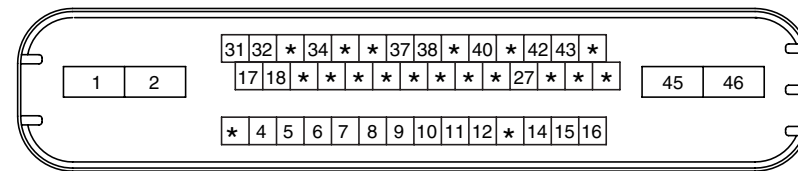

AMP\_ESP\_46F\_B

**CGG45**

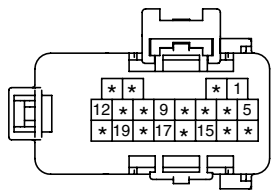

KET\_DIAG\_20F\_B\_BRK\_C

**CHG-K**

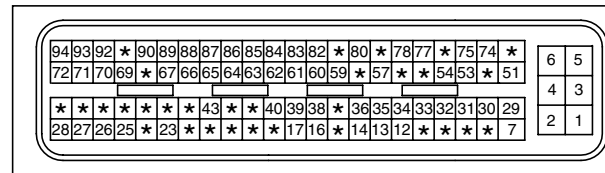

AMP\_ECU\_94F\_B

BLANK

**CHG41**

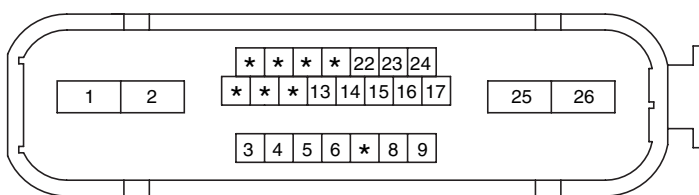

AMP\_ABS\_26F\_B

**CHG42**

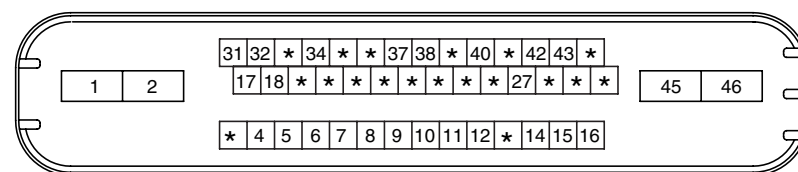

AMP\_ESP\_46F\_B

**CHG45**

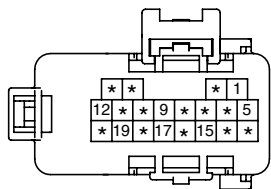

KET\_DIAG\_20F\_B\_BRK\_C

**F25-A**

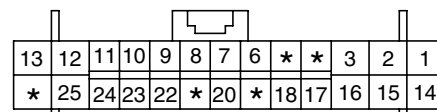

AMP\_0407\_26F\_W\_HD

**M04-B**

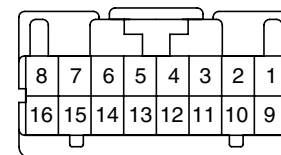

KET\_0407\_16F\_W

**M05-B**

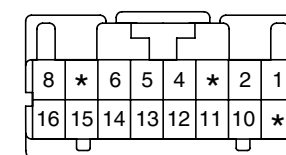

KET\_0407\_16F\_W

# DATA LINK DETAILS

## Data Link Details (4)

SD200-4

**M10**

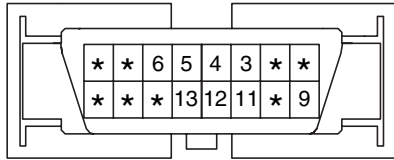

MLX\_OBDII\_16F\_B\_SIN

**M30**

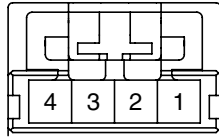

AMP\_MQS\_04F\_Y\_040

**M49**

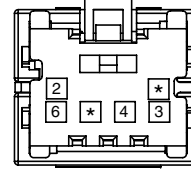

KET\_040III\_06F\_W

**M49R**

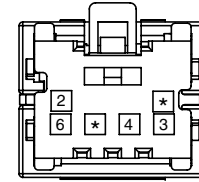

KET\_040III\_06F\_W

**M61**

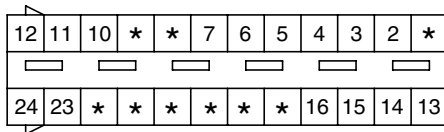

AMP\_ABG\_24F\_Y\_ECU\_TD

**BLANK**

**BLANK**

**BLANK**

Cooling System (1)

SD253-1

G4FC - GSL 1.6L

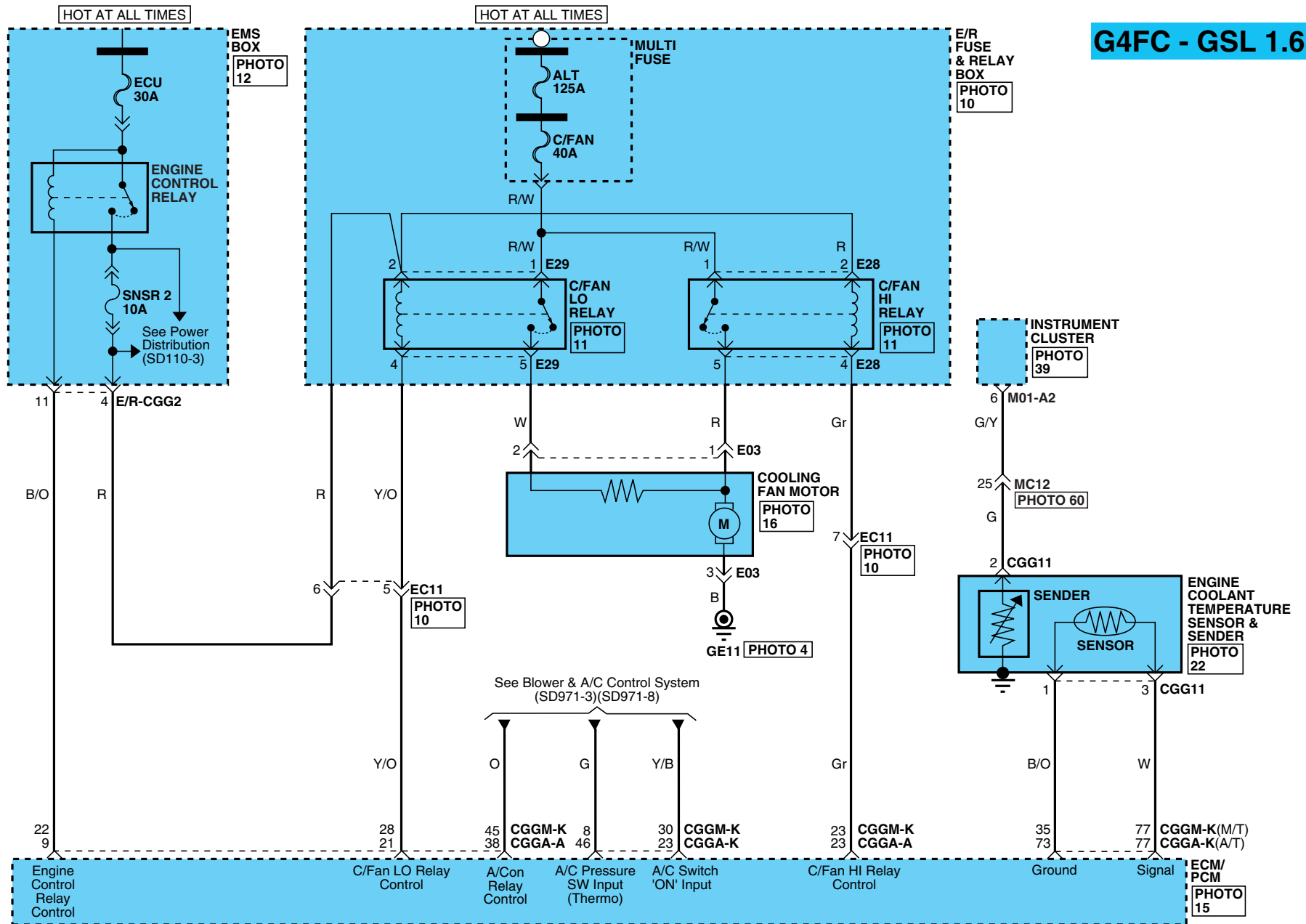



# COOLING SYSTEM

## Cooling System (2)

SD253-2

**G4KD - GSL 2.0L**

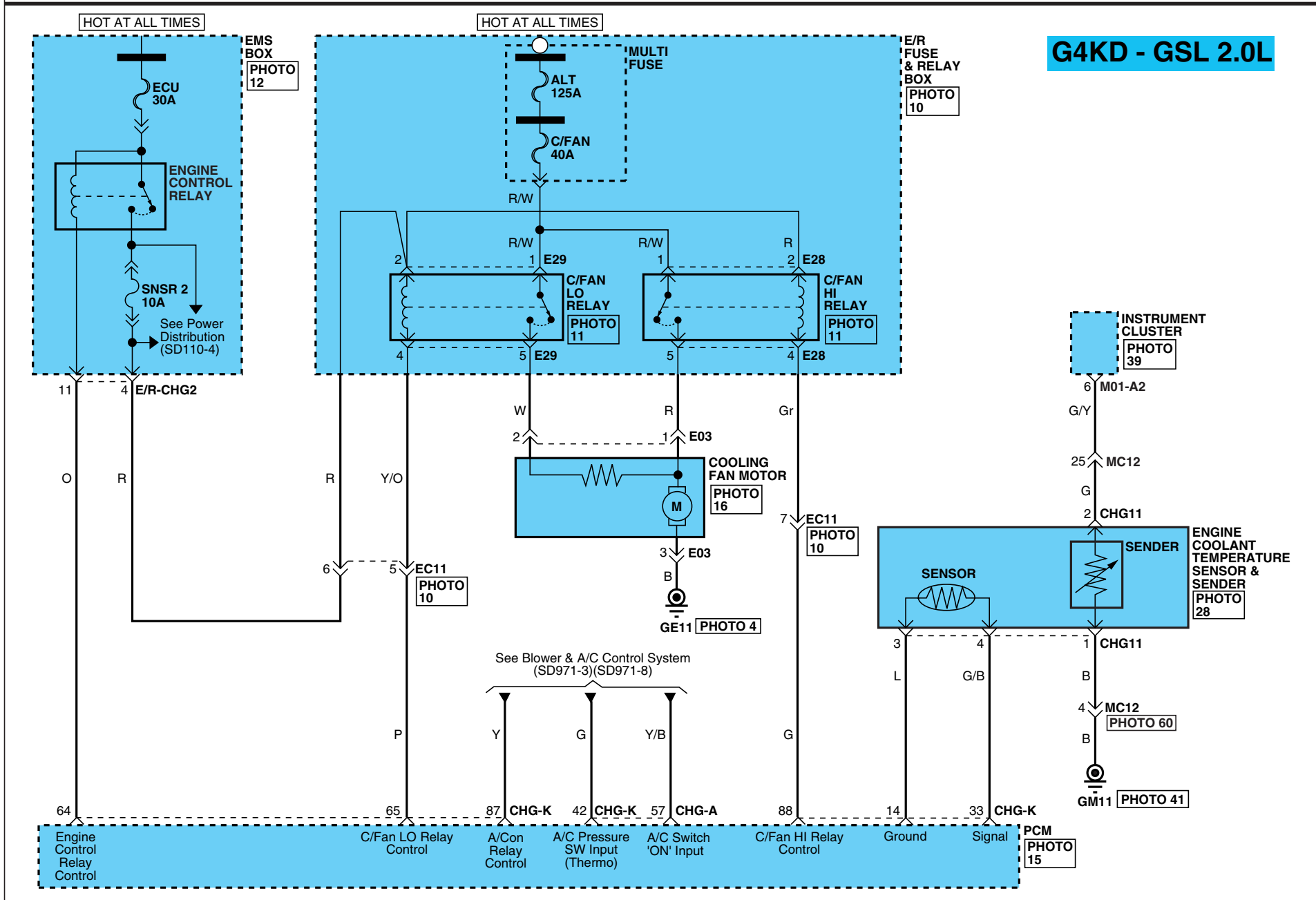

# COOLING SYSTEM

## Cooling System (3)

SD253-3

**CGGA-A**

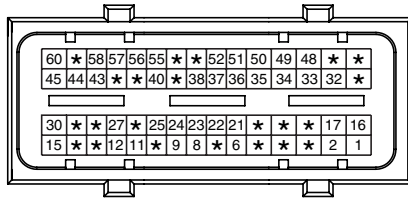

AMP\_ECU\_60F\_B

**CGGA-K**

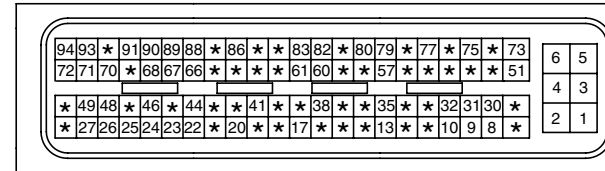

AMP\_ECU\_94F\_B

**CGGM-K**

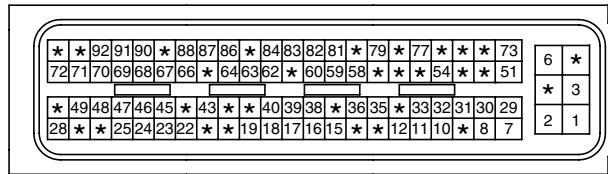

AMP\_ECU\_94F\_B

**CGG11**

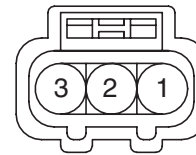

KUM\_62Z\_03F\_B\_WTS

**BLANK**

**CHG-A**

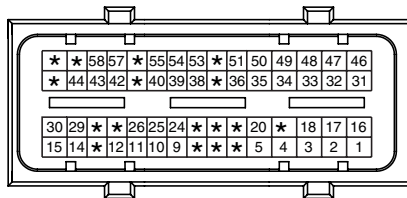

AMP\_ECU\_60F\_B\_A

**CHG-K**

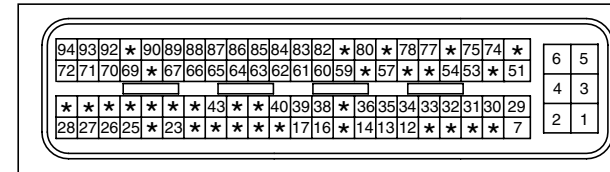

AMP\_ECU\_94F\_B

**CHG11**

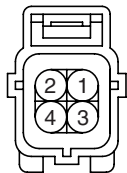

AMP\_EJWP\_04F\_B

**E03**

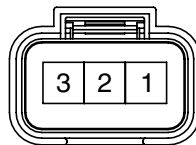

AMP\_SPTWP\_03F\_B

**E28**

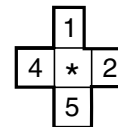

CR05F012

**E29**

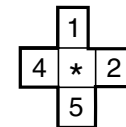

CR05F012

**M01-A2**

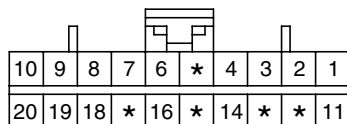

AMP\_040M2\_20F\_B

**BLANK**

**BLANK**

**BLANK**

**COOLING SYSTEM**

Cooling System (4)

**SD253-4**

**MEMO**

MFI Control System (G4FC-GSL 1.6L) (1)

SD313-1

**GAMMA - 1.6L**

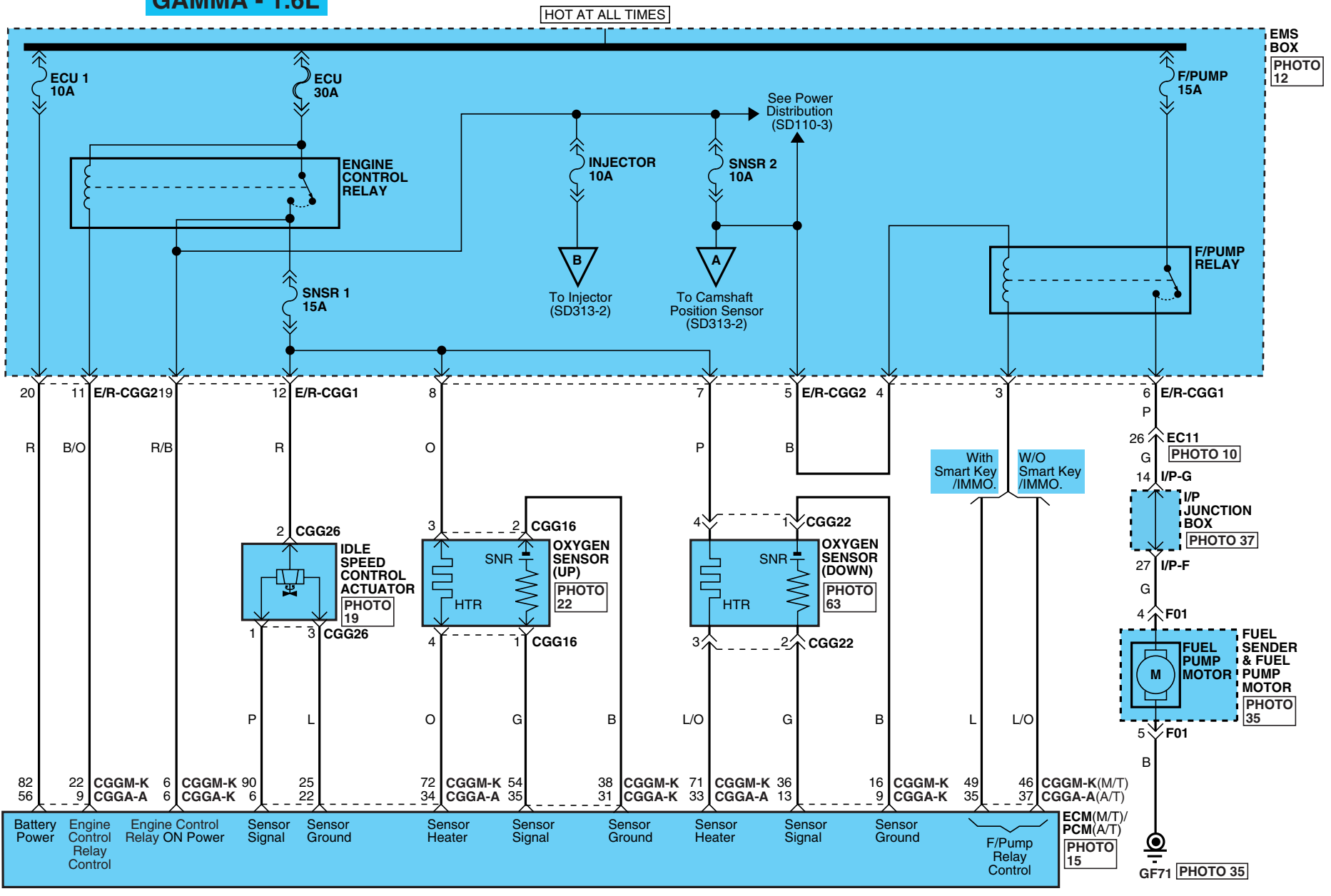

MFI CONTROL SYSTEM

MFI Control System (G4FC-GSL 1.6L) (2)

SD313-2

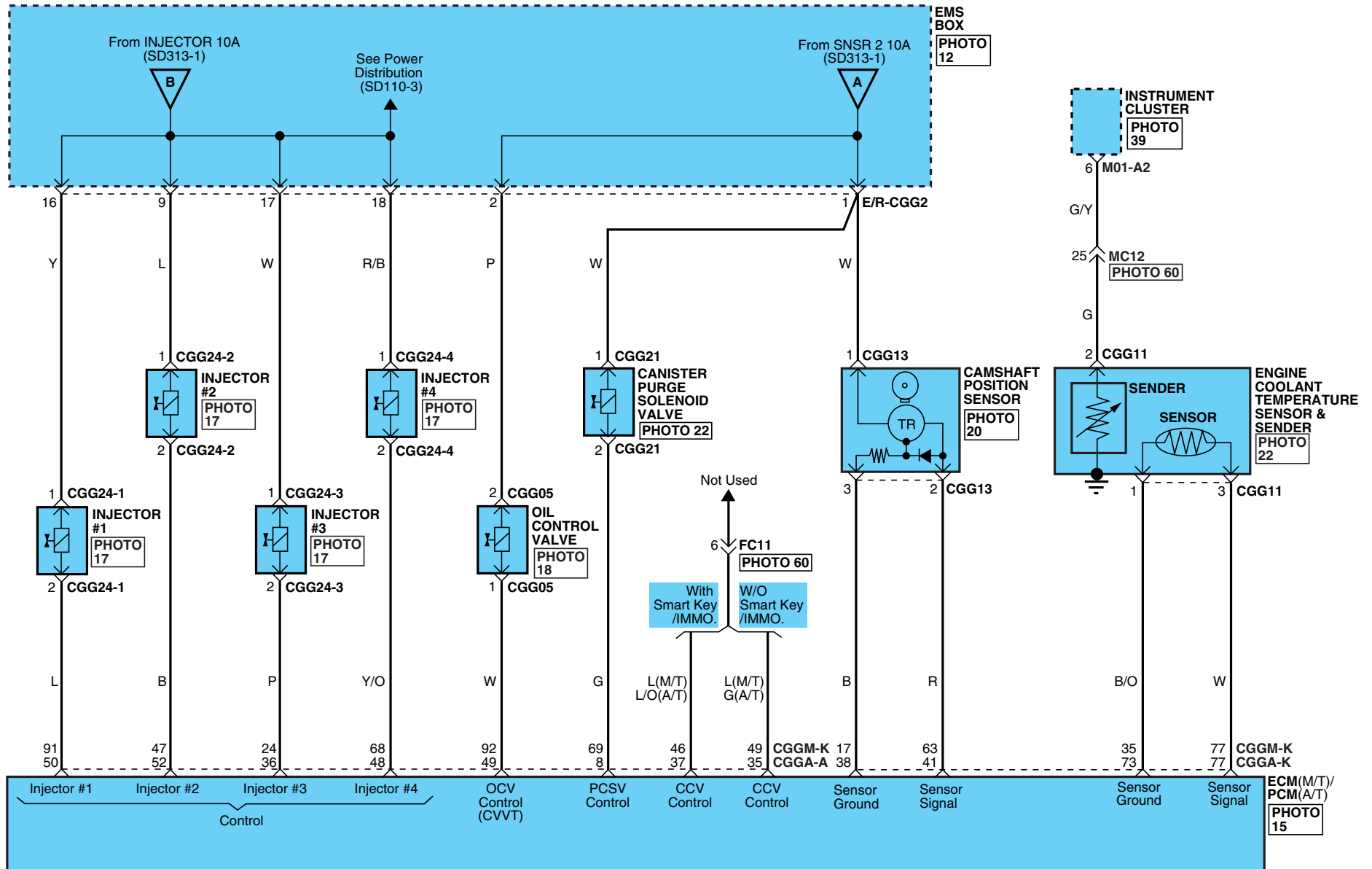

# MFI CONTROL SYSTEM

## MFI Control System (G4FC-GSL 1.6L) (3)

SD313-3

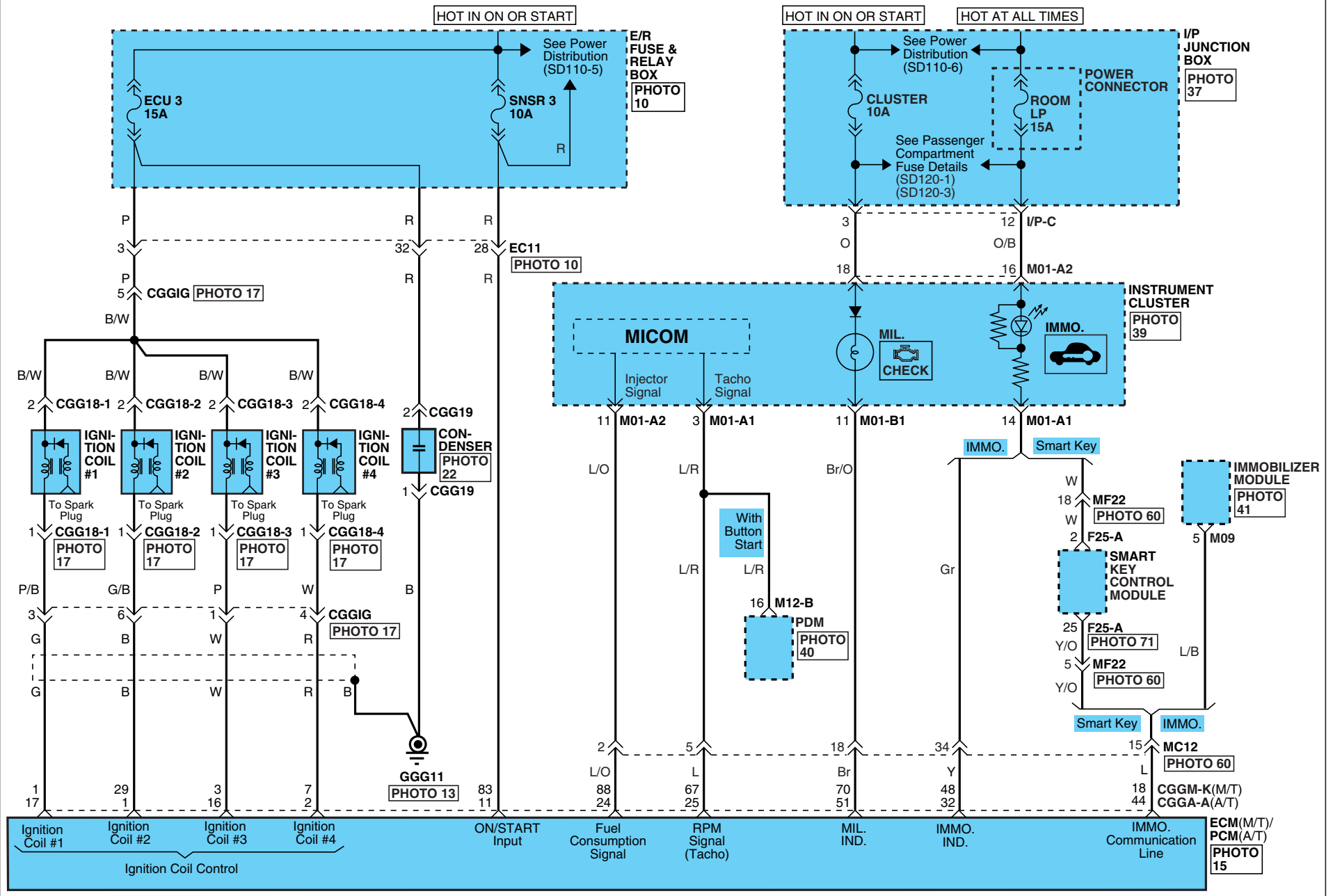

MFI CONTROL SYSTEM

MFI Control System (G4FC-GSL 1.6L) (4)

SD313-4

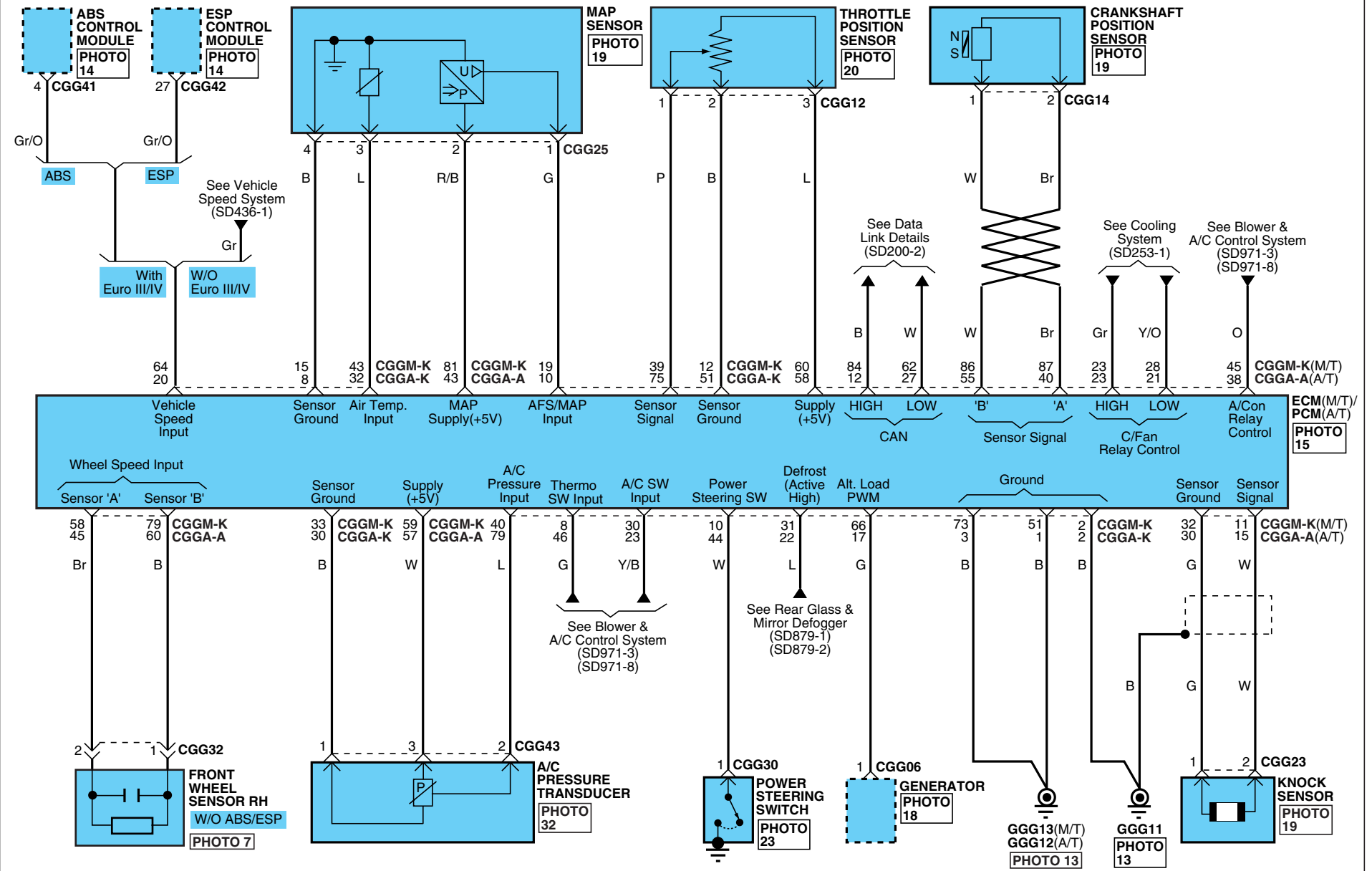

# MFI CONTROL SYSTEM

## MFI Control System (G4FC-GSL 1.6L) (5)

SD313-5

**CGGA-A**

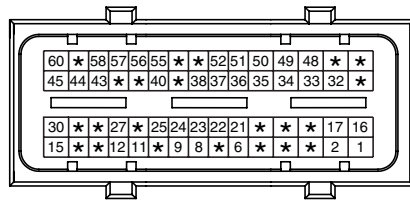

AMP\_ECU\_60F\_B

**CGGA-K**

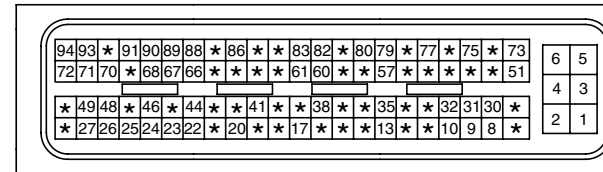

AMP\_ECU\_94F\_B

**CGGM-K**

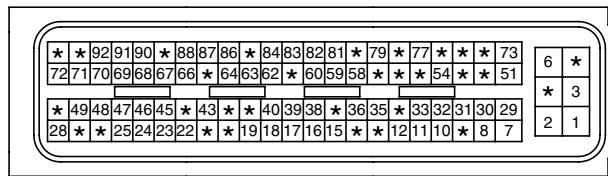

AMP\_ECU\_94F\_B

**CGG05**

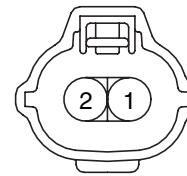

KET\_090WP\_02F\_B\_L

**CGG06**

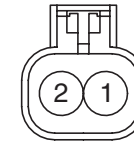

KET\_58X\_02F\_B

**CGG11**

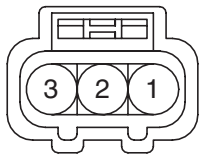

KUM\_62Z\_03F\_B\_WTS

**CGG12**

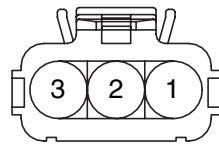

AMP\_JPT\_03F\_B\_BOSCH

**CGG13**

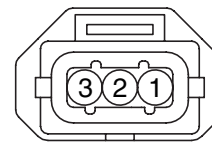

AMP\_JPT\_03F\_B\_BSH3

**CGG14**

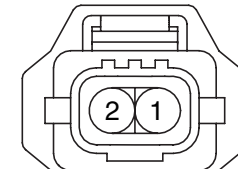

AMP\_JPT\_02F\_B\_BSH2

**CGG16**

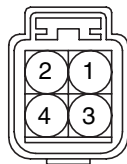

KUM\_NMWP\_04F\_B

**CGG18-1**

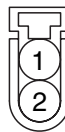

MLX\_090WP\_2F

**CGG18-2**

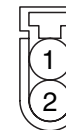

MLX\_090WP\_2F

**CGG18-3**

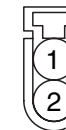

MLX\_090WP\_2F

**CGG18-4**

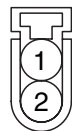

MLX\_090WP\_2F

**CGG19**



MLX\_090CIGAR\_02F\_B

**CGG21**

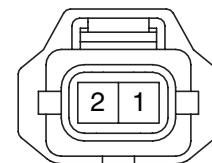

AMP\_JPT\_02F\_B\_BSH2

**CGG22**

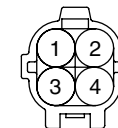



KET\_SWP\_04M\_B



# MFI CONTROL SYSTEM

## MFI Control System (G4FC-GSL 1.6L) (6)

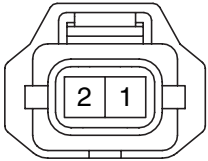
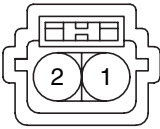
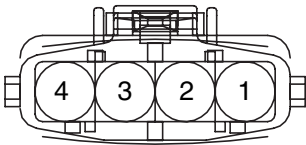
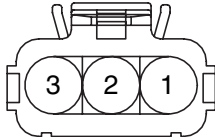
SD313-6

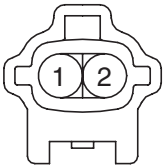
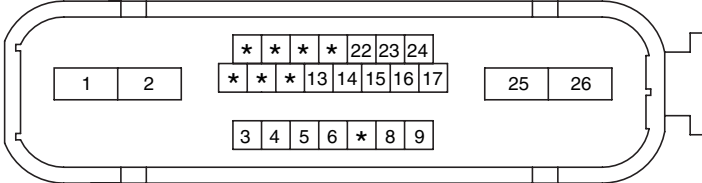
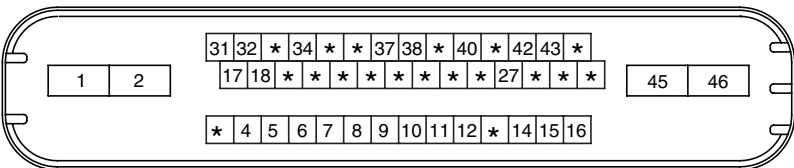
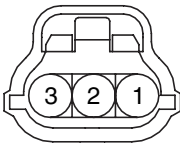
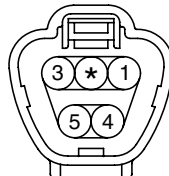
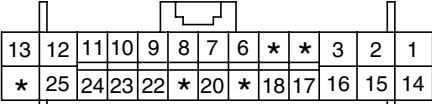
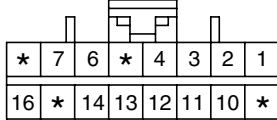
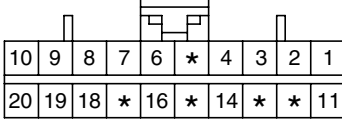
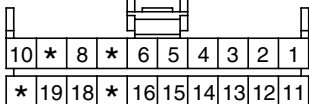
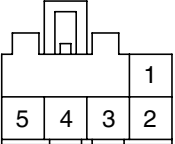
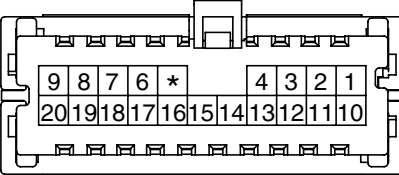
<p><b>CGG23</b></p>  <p>AMP_JPT_02F_BSH2</p>	<p><b>CGG24-1/2/3/4</b></p>  <p>KUM_NDWP_02F_Gr</p>	<p><b>CGG25</b></p>  <p>AMP_JPT_04F_B_BOSCH</p>	<p><b>CGG26</b></p>  <p>AMP_JPT_03F_B_BOSCH</p>
<p><b>CGG30</b></p>  <p>KUM_NMWP_01F_B</p>	<p><b>CGG32</b></p>  <p>KET_090IWP_02M_B</p>	<p><b>CGG41</b></p>  <p>AMP_ABS_26F_B</p>	
<p><b>CGG42</b></p>  <p>AMP_ESP_46F_B</p>		<p><b>CGG43</b></p>  <p>KET_040WP_03F_B</p>	<p><b>F01</b></p>  <p>KET_090IWP_05F_Gr_2</p>
<p><b>F25-A</b></p>  <p>AMP_0407_26F_W_HD</p>	<p><b>M01-A1</b></p>  <p>AMP_040M2_16F_W</p>	<p><b>M01-A2</b></p>  <p>AMP_040M2_20F_B</p>	<p><b>M01-B1</b></p>  <p>AMP_040M1_20F_B</p>
<p><b>M09</b></p>  <p>KUM_CDR_05F_W</p>	<p><b>M12-B</b></p>  <p>KET_040III_20F_W</p>	<p><b>BLANK</b></p>	<p><b>BLANK</b></p>

MFI CONTROL SYSTEM

MFI Control System (G4KD-GSL 2.0L) (1)

SD313-7

THETA II 2.0L

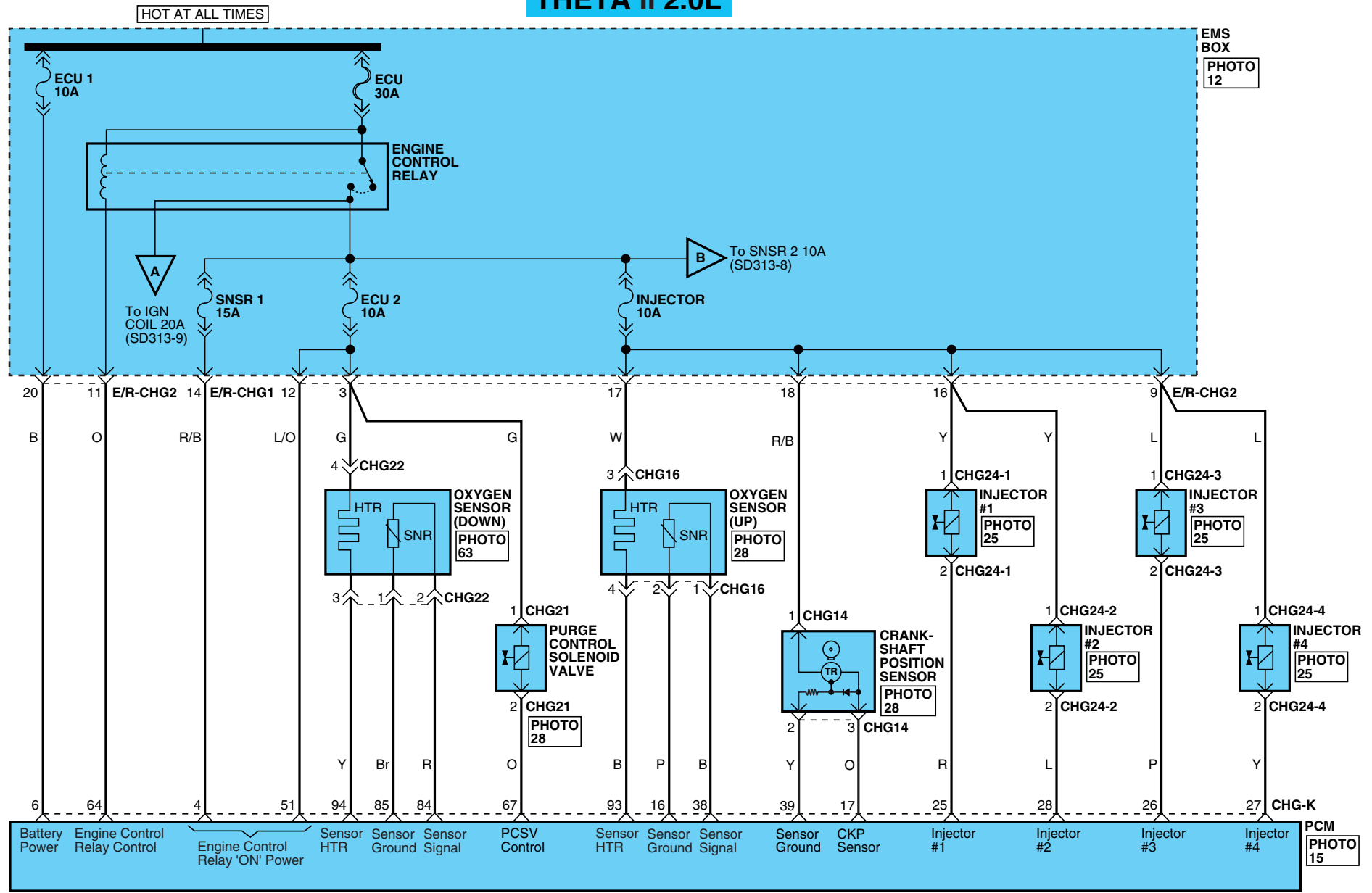

# MFI CONTROL SYSTEM

## MFI Control System (G4KD-GSL 2.0L) (2)

SD313-8

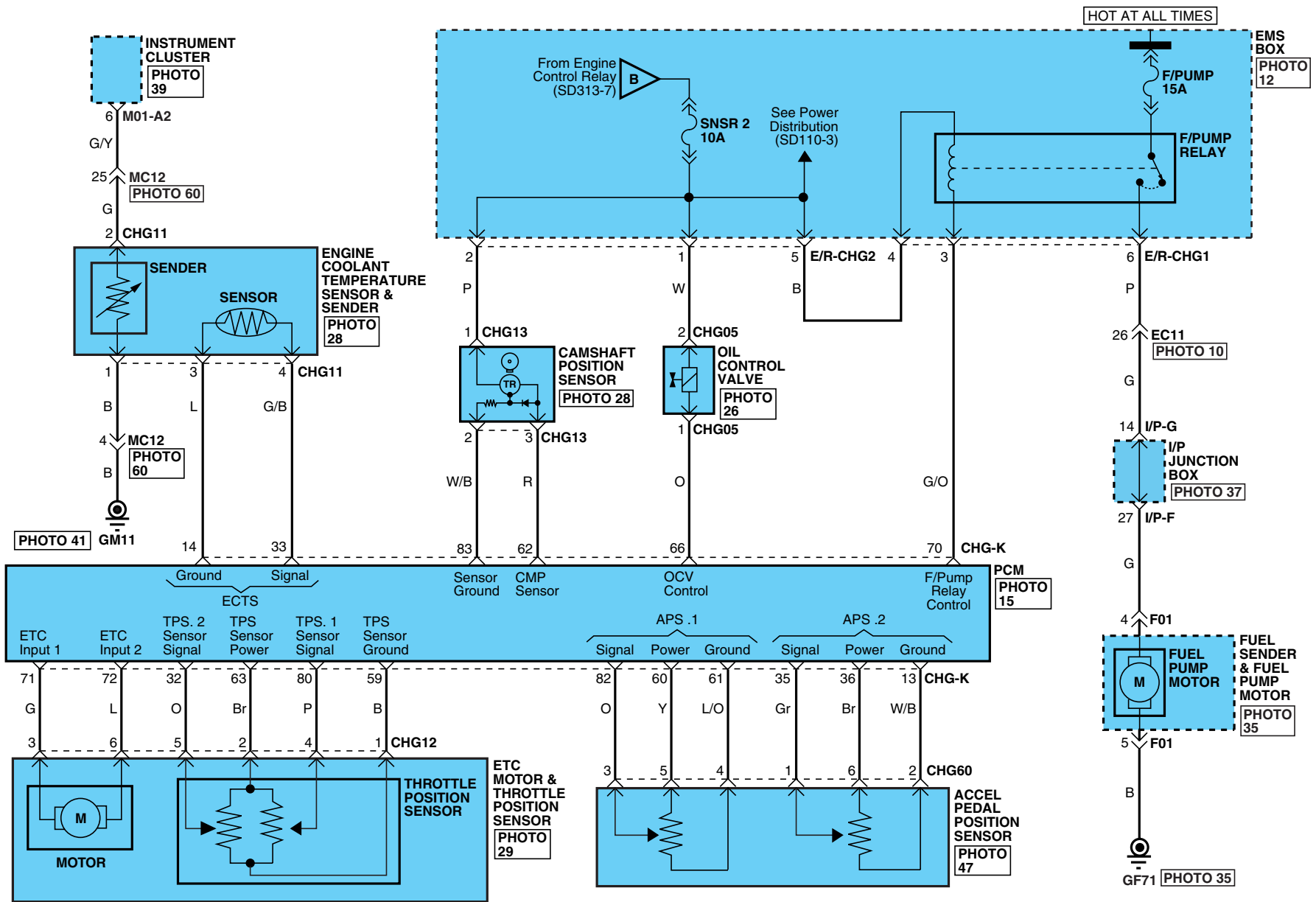

# MFI CONTROL SYSTEM

## MFI Control System (G4KD-GSL 2.0L) (3)

SD313-9

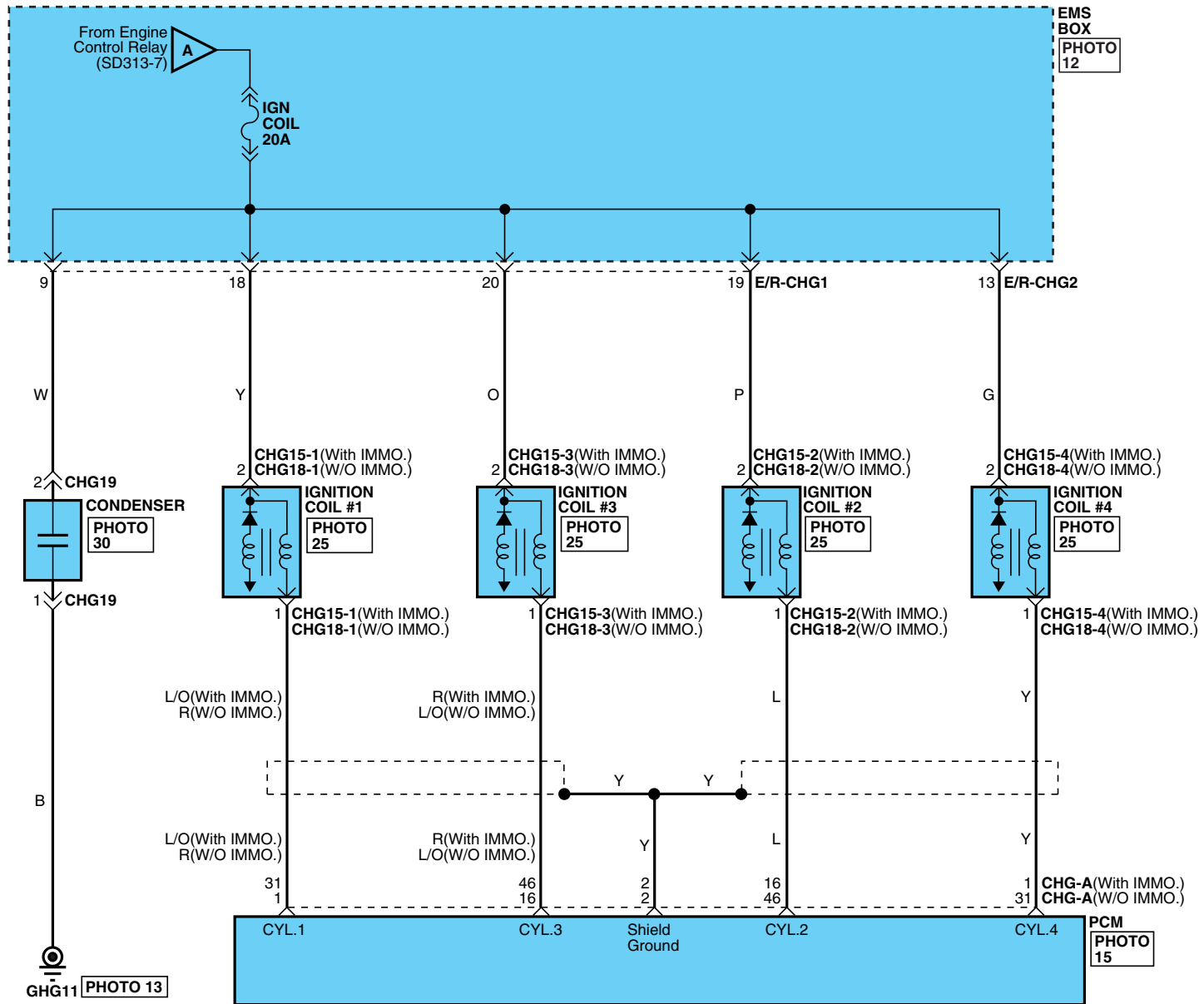

# MFI CONTROL SYSTEM

## MFI Control System (G4KD-GSL 2.0L) (4)

SD313-10

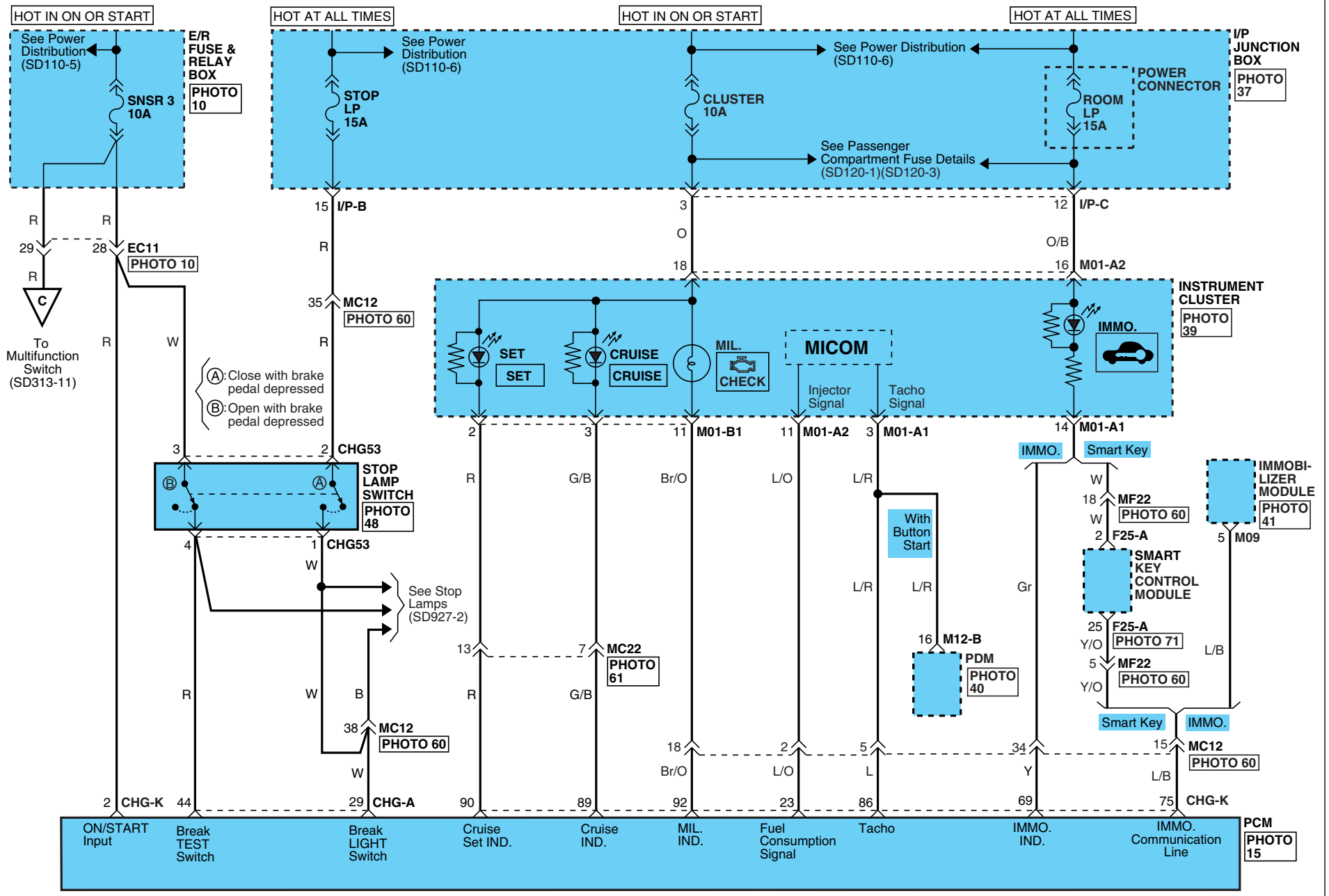

# MFI CONTROL SYSTEM

## MFI Control System (G4KD-GSL 2.0L) (5)

SD313-11

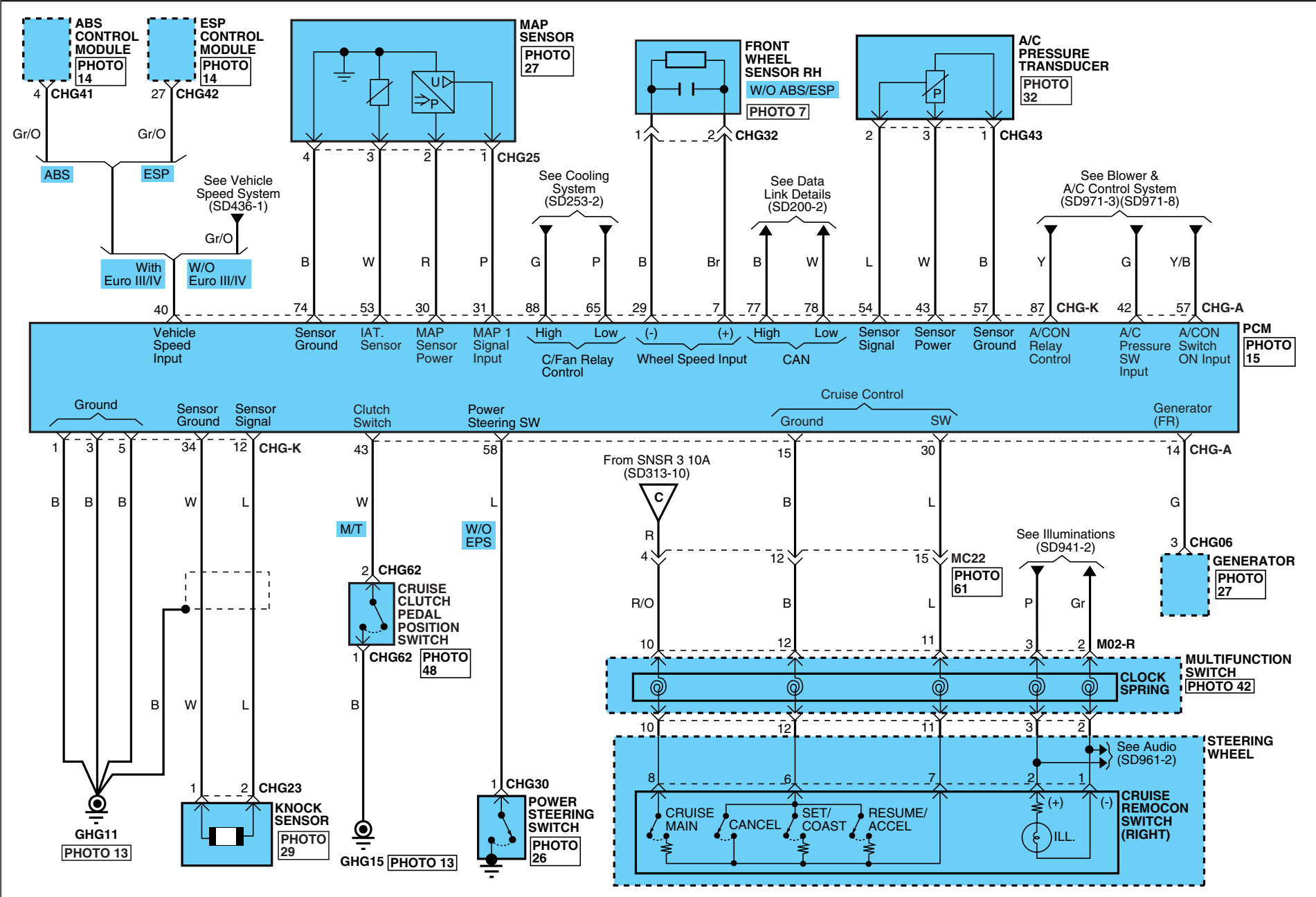

# MFI CONTROL SYSTEM

## MFI Control System (G4KD-GSL 2.0L) (6)

SD313-12

**CHG-A**

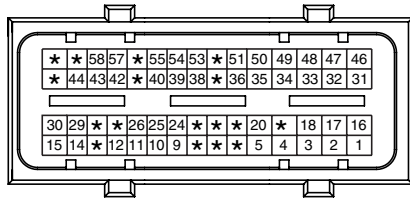

AMP\_ECU\_60F\_B\_A

**CHG-K**

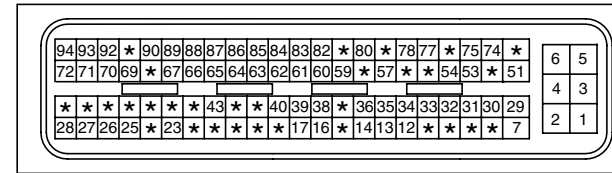

AMP\_ECU\_94F\_B

**CHG05**



KET\_090WP\_02F\_B\_L

**CHG06**

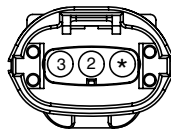

KET\_090IWP\_03F\_B

**CHG11**



AMP\_EJWP\_04F\_B

**CHG12**

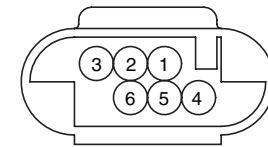

AMP\_MQSWP\_06F\_B\_1

**CHG13**



SUM\_090IWP\_03F\_GR\_R

**CHG14**

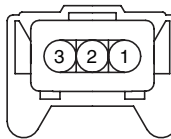

AMP\_JPT\_03F\_B\_S2

**CHG15-1**

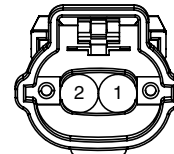

KET\_090WP\_02F\_B\_L3

**CHG15-2**

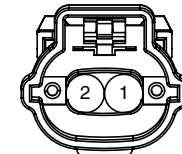

KET\_090WP\_02F\_B\_L3

**CHG15-3**

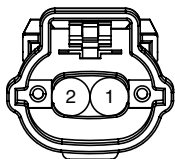

KET\_090WP\_02F\_B\_L3

**CHG15-4**

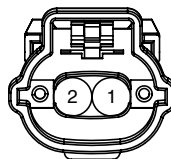

KET\_090WP\_02F\_B\_L3

**CHG16**



KET\_090IWP\_04F\_B

**CHG18-1**

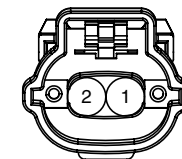

KET\_090WP\_02F\_B\_L3

**CHG18-2**

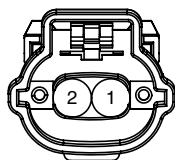

KET\_090WP\_02F\_B\_L3

**CHG18-3**

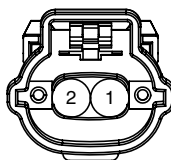

KET\_090WP\_02F\_B\_L3

**CHG18-4**

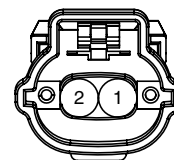

KET\_090WP\_02F\_B\_L3

**CHG19**









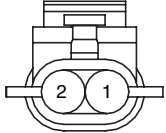
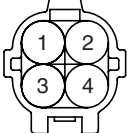
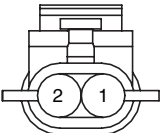

MLX\_090CIGAR\_02F\_B

**MFI CONTROL SYSTEM**

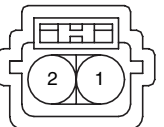
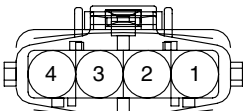
**MFI Control System (G4KD-GSL 2.0L) (7)**

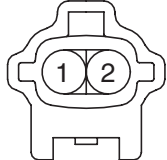
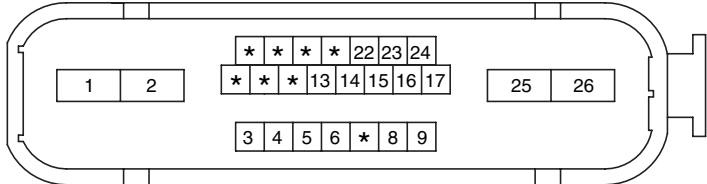
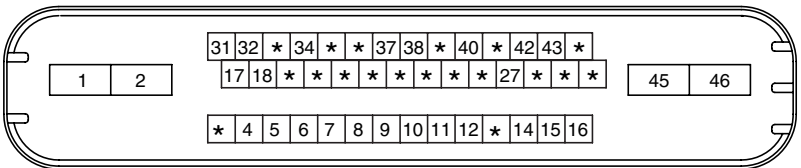
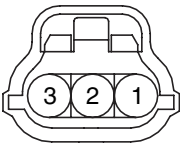
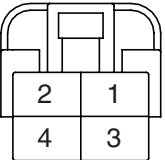
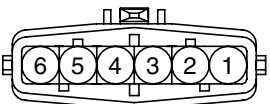
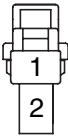
**SD313-13**

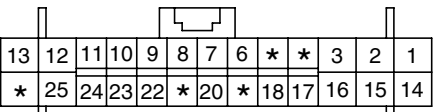
<p><b>CHG21</b></p>  <p>PKD_MP150_02F_B</p>	<p><b>CHG22</b></p>  <p>KET_SWP_04M_B</p>	<p><b>CHG23</b></p>  <p>PKD_150WP_02F_GR</p>	<p><b>CHG24-1</b></p>  <p>KUM_NDWP_02F_Gr</p>
<p><b>CHG24-2</b></p>  <p>KUM_NDWP_02F_Gr</p>	<p><b>CHG24-3</b></p>  <p>KUM_NDWP_02F_Gr</p>	<p><b>CHG24-4</b></p>  <p>KUM_NDWP_02F_Gr</p>	<p><b>CHG25</b></p>  <p>AMP_JPT_04F_B_BOSCH</p>
<p><b>CHG30</b></p>  <p>KUM_NMWP_01F_B</p>	<p><b>CHG32</b></p>  <p>KET_090IWP_02M_B</p>	<p><b>CHG41</b></p>  <p>AMP_ABS_26F_B</p>	
<p><b>CHG42</b></p>  <p>AMP_ESP_46F_B</p>		<p><b>CHG43</b></p>  <p>KET_040WP_03F_B</p>	<p><b>CHG53</b></p>  <p>KET_250DL_04F_W</p>
<p><b>CHG60</b></p>  <p>AMP_JPT_06F_B</p>	<p><b>CHG62</b></p>  <p>KET_250DL_02F_W</p>	<p><b>F01</b></p>  <p>KET_090IWP_05F_Gr_2</p>	<p><b>F25-A</b></p>  <p>AMP_0407_26F_W_HD</p>



# MFI CONTROL SYSTEM

## MFI Control System (G4KD-GSL 2.0L) (8)

SD313-14

**M01-A1**

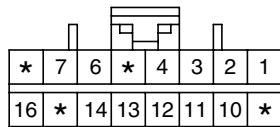

AMP\_040M2\_16F\_W

**M01-A2**

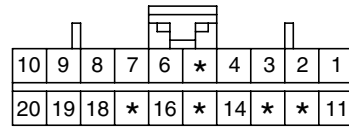

AMP\_040M2\_20F\_B

**M01-B1**

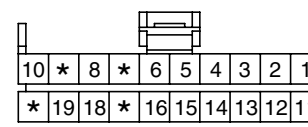

AMP\_040M1\_20F\_B

**M12-B**

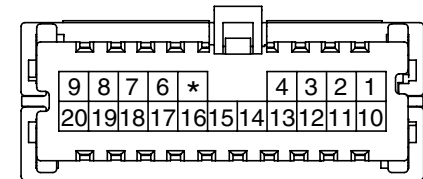

KET\_040III\_20F\_W

**M02-R**

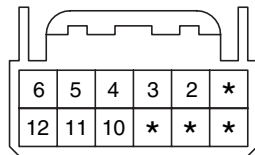

AMP\_025\_12F\_W

**M09**

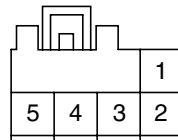

KUM\_CDR\_05F\_W

**BLANK**

**BLANK**

W/O Button Start

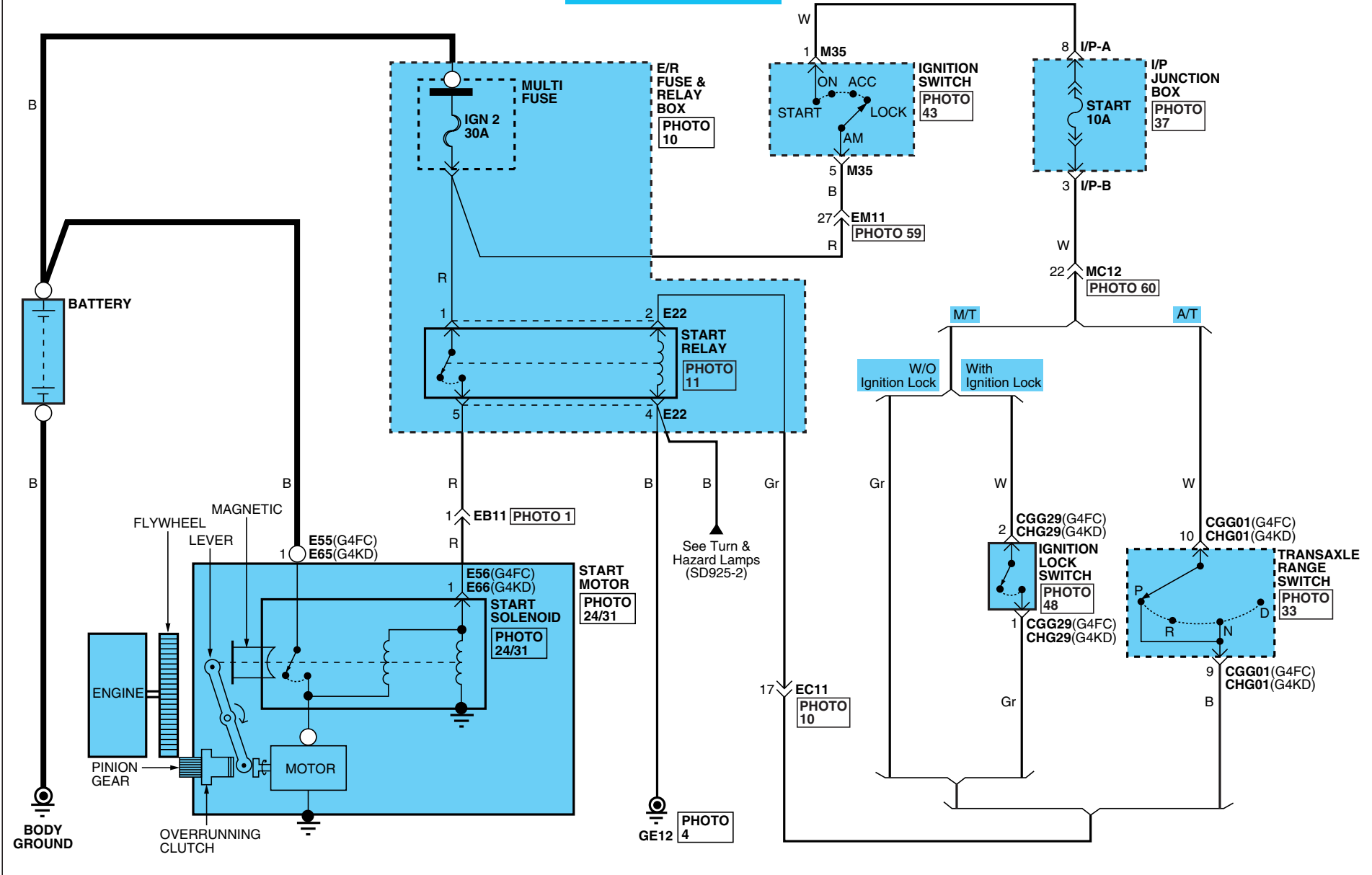

# STARTING SYSTEM

## Starting System (2)

SD360-2

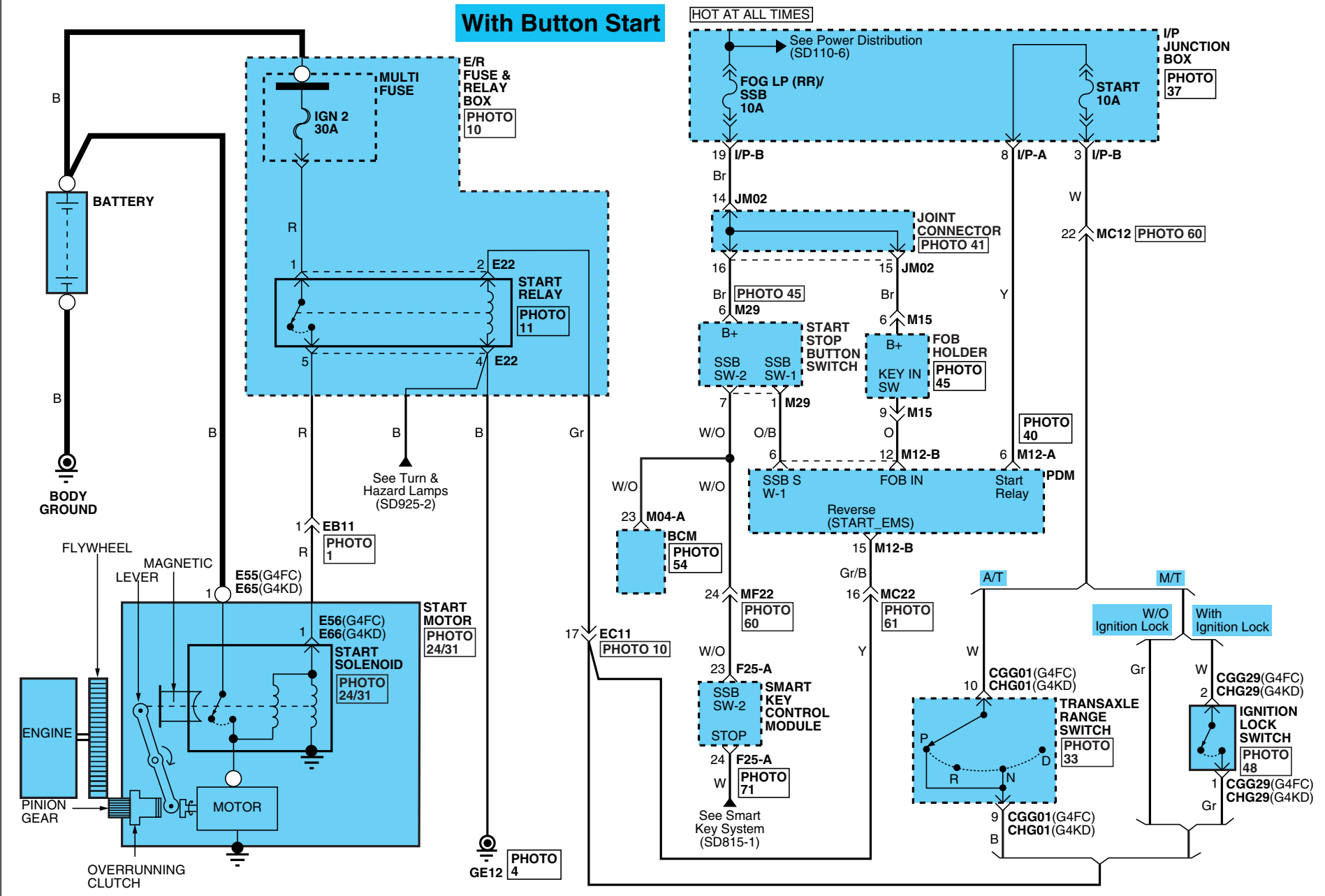

### With Button Start



# STARTING SYSTEM

## Starting System (3)

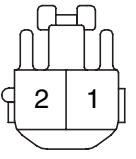
SD360-3

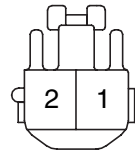
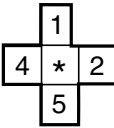
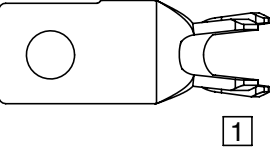
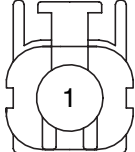
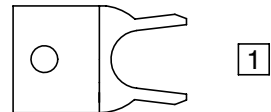
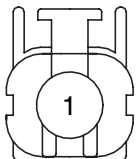
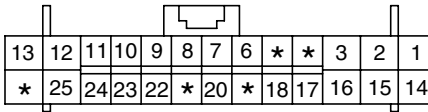
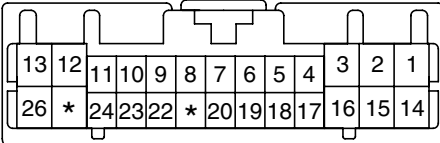
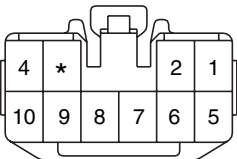
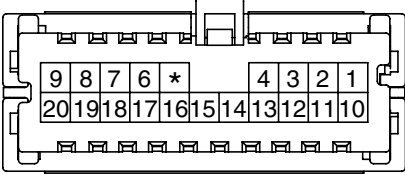
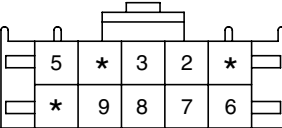
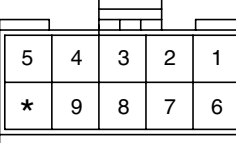
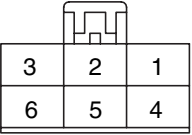
<p><b>CGG01</b></p>  <p>KET_SSD_10F_B_A</p>	<p><b>CGG29</b></p>  <p>KET_090II_02F_W_L</p>	<p><b>CHG01</b></p>  <p>KET_SSD_10F_B_A</p>	<p><b>CHG29</b></p>  <p>KET_090II_02F_W_L</p>
<p><b>E22</b></p>  <p>CR05F012</p>	<p><b>E55</b></p>  <p>CHT_STMTRTMLL_01F_N</p>	<p><b>E56</b></p>  <p>KET_58X_01F_B</p>	<p><b>E65</b></p>  <p>CHT_TMLSTMTR_01F_N</p>
<p><b>E66</b></p>  <p>KET_58X_01F_B</p>	<p><b>F25-A</b></p>  <p>AMP_0407_26F_W_HD</p>	<p><b>M04-A</b></p>  <p>KET_0407_26F_W</p>	<p><b>M12-A</b></p>  <p>KET_090II_10F_W</p>
<p><b>M12-B</b></p>  <p>KET_040III_20F_W</p>	<p><b>M15</b></p>  <p>YAZ_SP_10F_W</p>	<p><b>M29</b></p>  <p>MLX_025_10F_B</p>	<p><b>M35</b></p>  <p>KUM_DSD_06F_B</p>

**STARTING SYSTEM**

Starting System (4)

SD360-4

MEMO

Charging System (1)

SD373-1

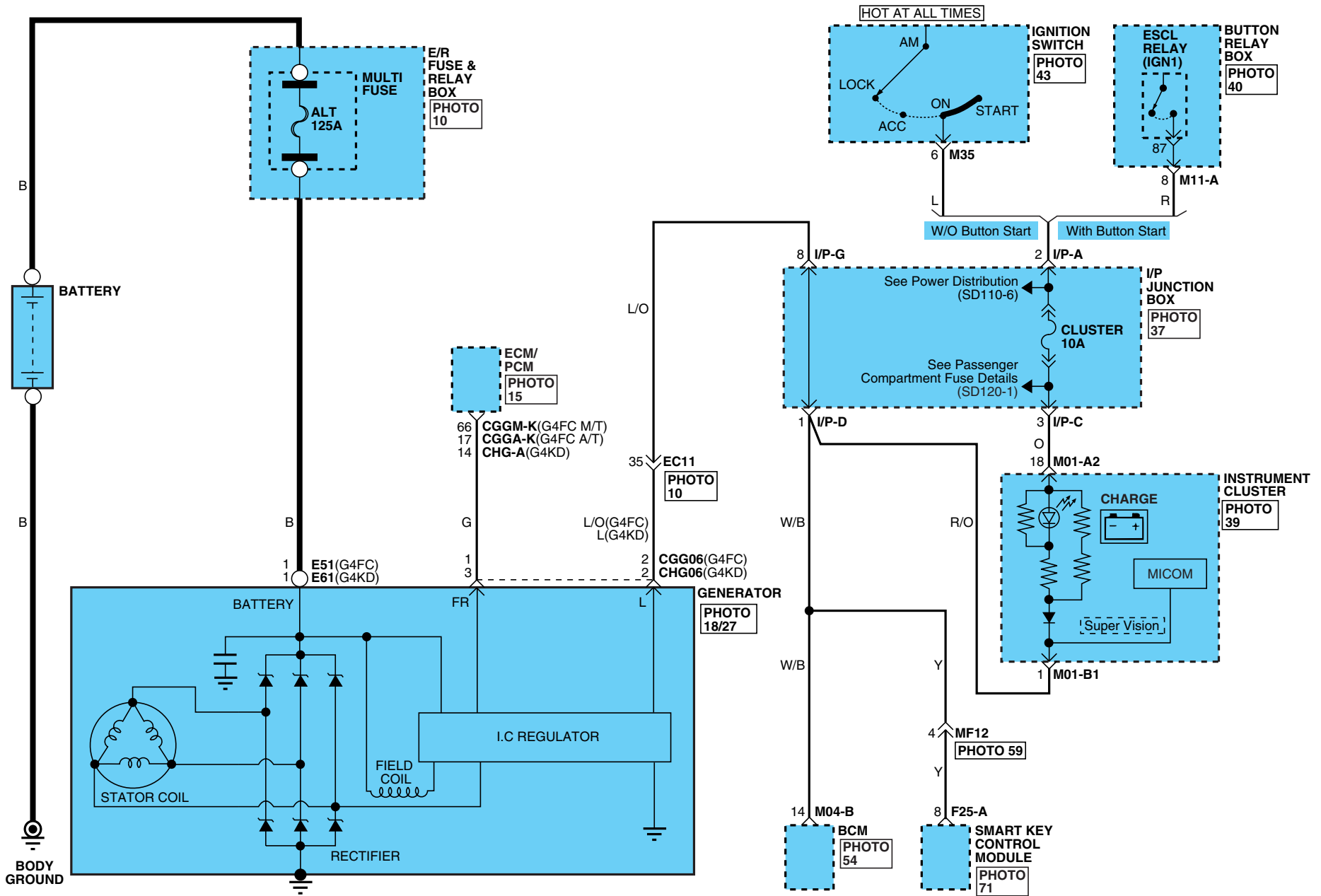

# CHARGING SYSTEM

## Charging System (2)

SD373-2

**CGGA-K**

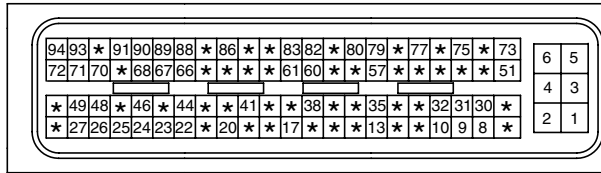

AMP\_ECU\_94F\_B

**CGGM-K**

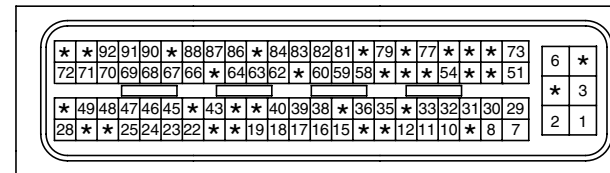

AMP\_ECU\_94F\_B

**CGG06**

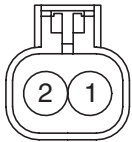

KET\_58X\_02F\_B

**CHG-A**

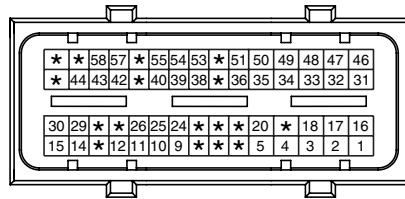

AMP\_ECU\_60F\_B\_A

**CHG06**

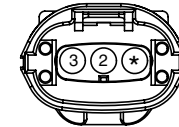

KET\_090IWP\_03F\_B

**E51**

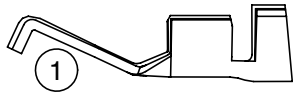

TML\_ALT\_GSL\_HD

**E61**

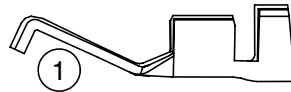

TML\_ALT\_GSL\_HD

**F25-A**

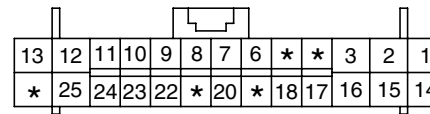

AMP\_0407\_26F\_W\_HD

**M01-A2**

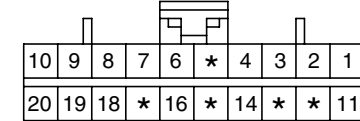

AMP\_040M2\_20F\_B

**M01-B1**

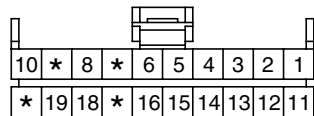

AMP\_040M1\_20F\_B

**M04-B**

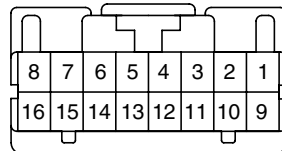

KET\_0407\_16F\_W

**M11-A**

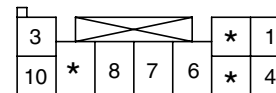

AMP\_0925\_10F\_W

**M35**

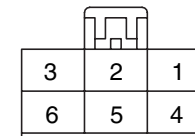

KUM\_DSD\_06F\_B

Vehicle Speed System (1)

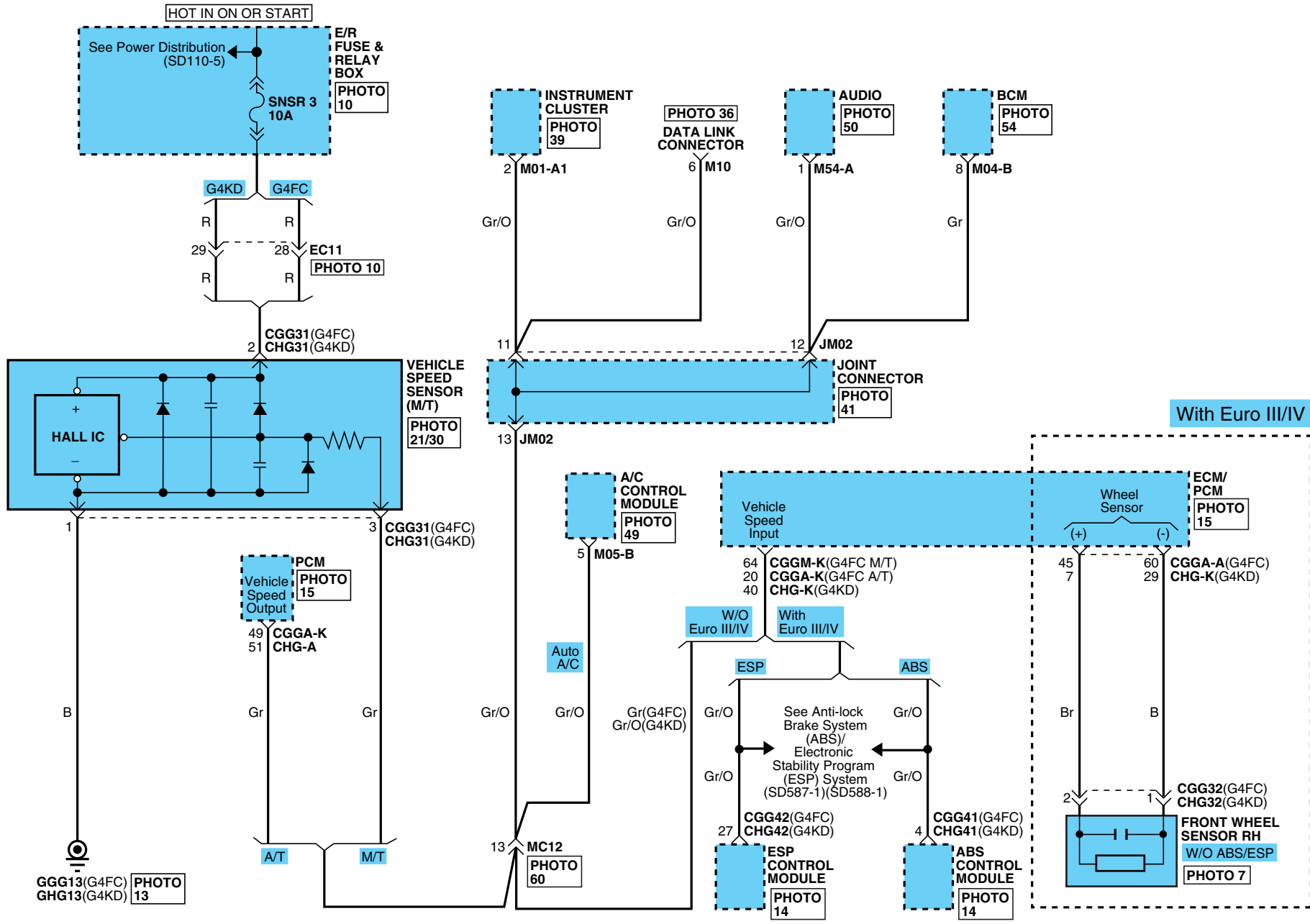



# VEHICLE SPEED SYSTEM

## Vehicle Speed System (2)

SD436-2

**CGGA-A**

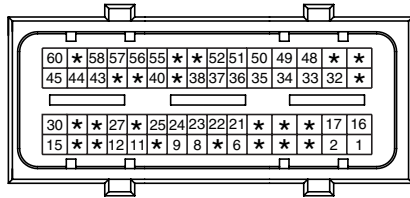

AMP\_ECU\_60F\_B

**CGGA-K**

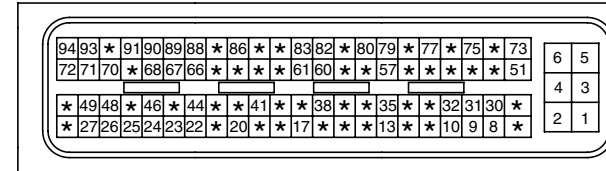

AMP\_ECU\_94F\_B

**CGGM-K**

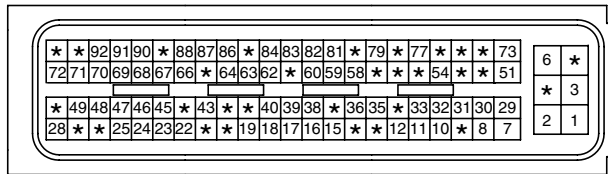

AMP\_ECU\_94F\_B

**CGG31**

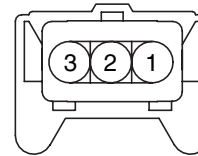

AMP\_JPT\_03F\_B\_S1

**CGG32**

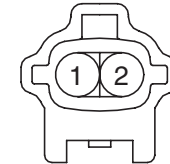

KET\_090IWP\_02M\_B

**CGG41**

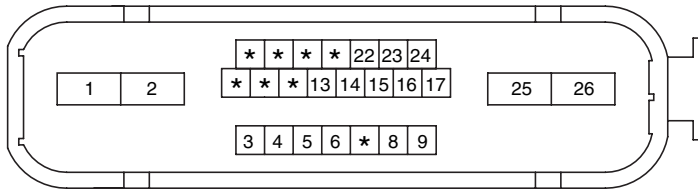

AMP\_ABS\_26F\_B

**CGG42**

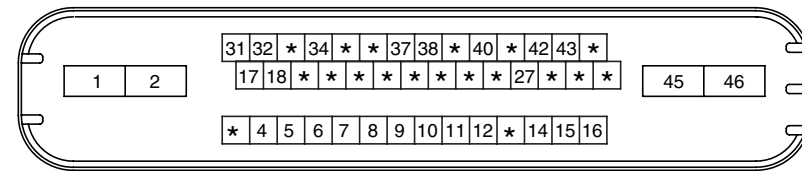

AMP\_ESP\_46F\_B

**CHG-K**

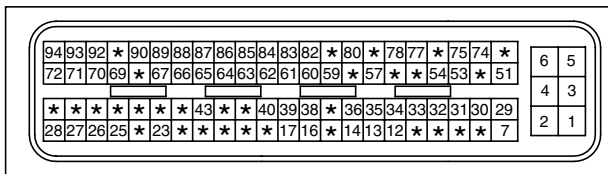

AMP\_ECU\_94F\_B

**CHG31**

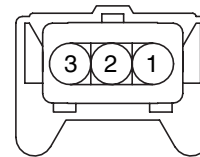

AMP\_JPT\_03F\_B\_S1

**CHG32**

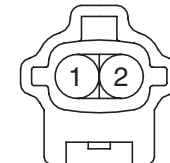

KET\_090IWP\_02M\_B

**CHG41**

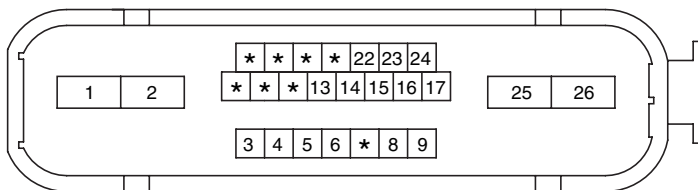

AMP\_ABS\_26F\_B

**CHG42**

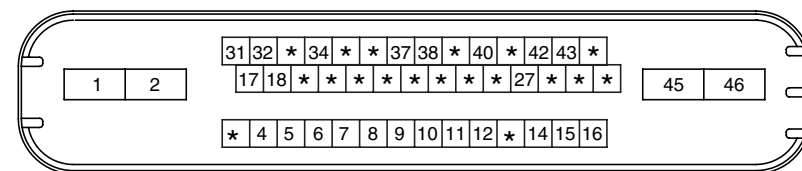

AMP\_ESP\_46F\_B

# VEHICLE SPEED SYSTEM

## Vehicle Speed System (3)

SD436-3

M01-A1

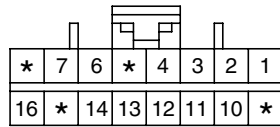

AMP\_040M2\_16F\_W

M04-B

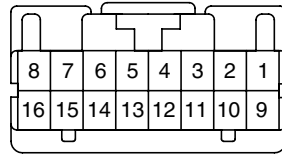

KET\_0407\_16F\_W

M05-B

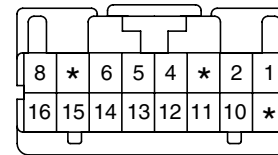

KET\_0407\_16F\_W

M10

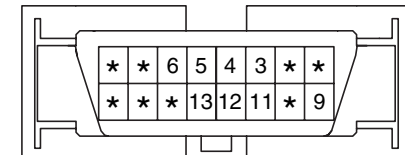

MLX\_OBDII\_16F\_B\_SIN

M54-A



AMP\_AUDIO\_08F\_GR\_D2

BLANK

BLANK

BLANK

**VEHICLE SPEED SYSTEM**

Vehicle Speed System (4)

**SD436-4**

**MEMO**

**Automatic Transaxle Control System (G4FC-GSL 1.6L) (1)**

**SD450-1**

**GAMMA 1.6L**

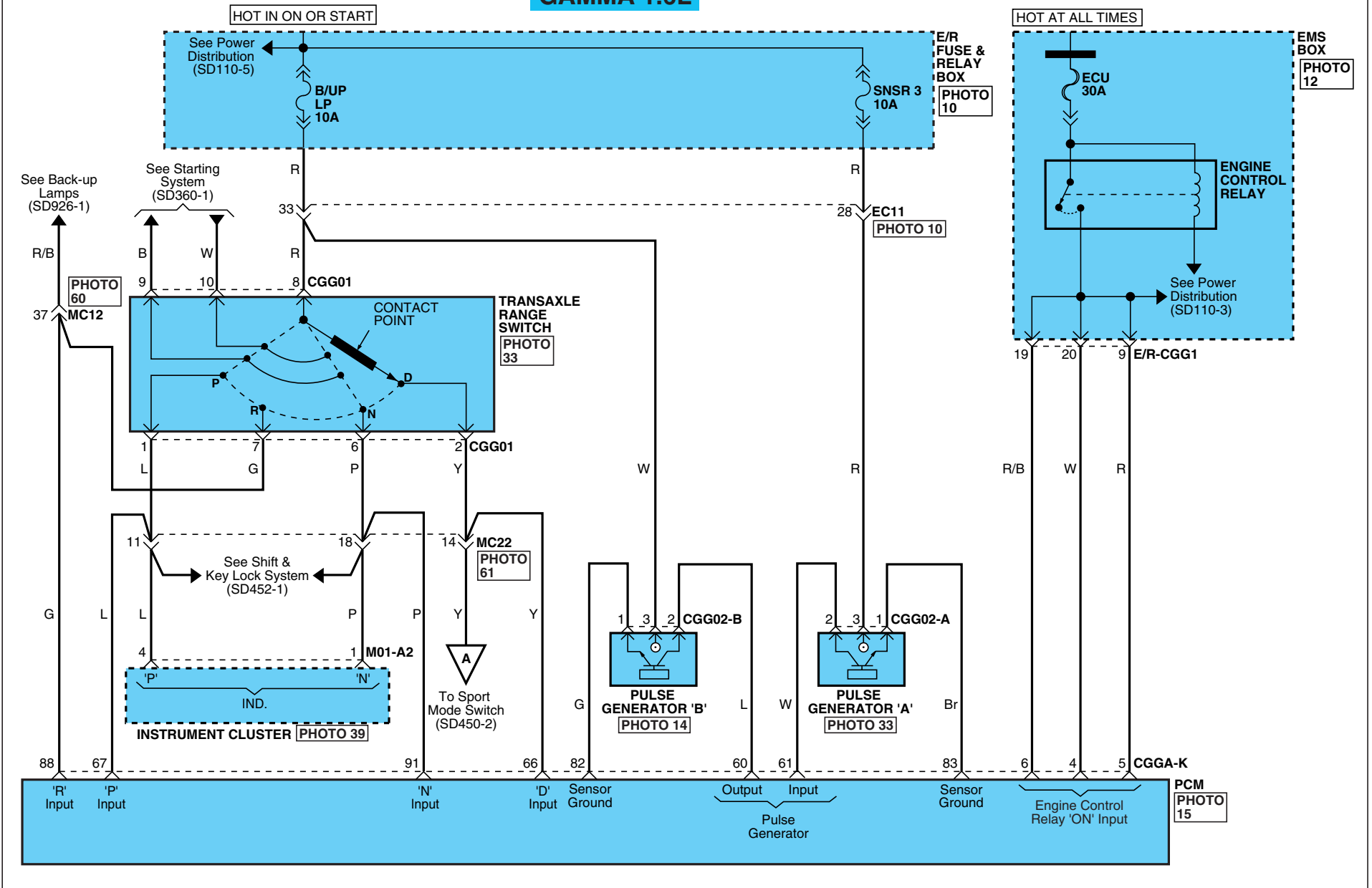

# AUTOMATIC TRANSAXLE CONTROL SYSTEM

## Automatic Transaxle Control System (G4FC-GSL 1.6L) (2)

SD450-2

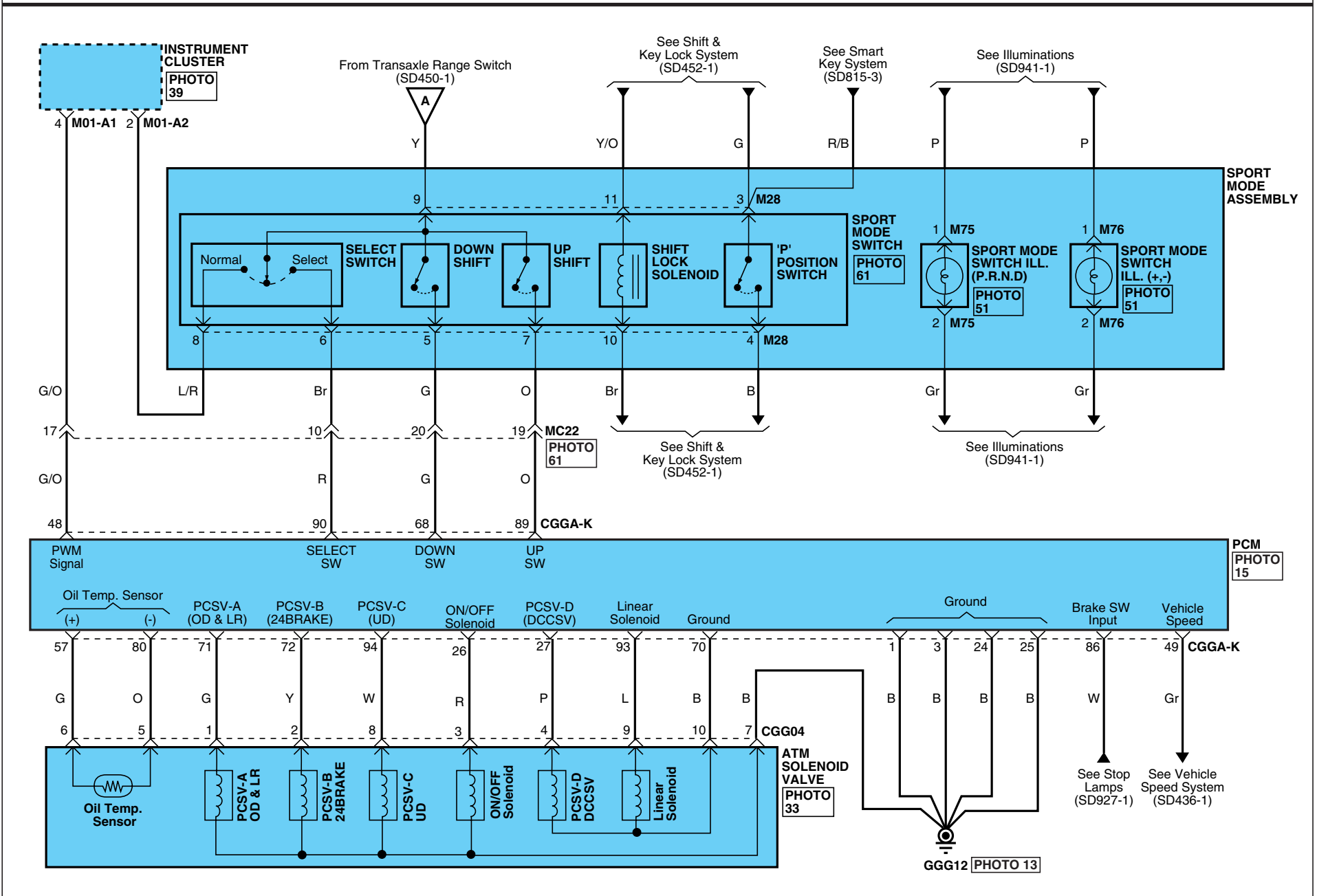

# AUTOMATIC TRANSAXLE CONTROL SYSTEM

## Automatic Transaxle Control System (G4FC-GSL 1.6L) (3)

SD450-3

**CGGA-K**

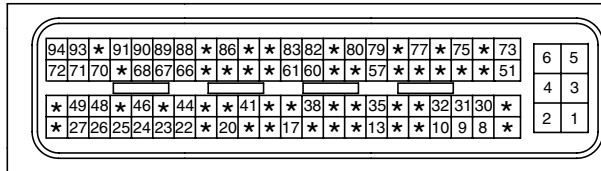

AMP\_ECU\_94F\_B

**CGG01**



KET\_SSD\_10F\_B\_A

**CGG02-A**

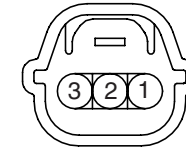

KET\_SSD\_03F\_Gr\_B

**CGG02-B**

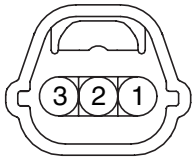

KET\_SSD\_03F\_B\_A

**CGG04**

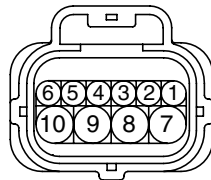

FCI\_FPC\_10F\_B

**M01-A1**

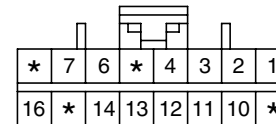

AMP\_040M2\_16F\_W

**M01-A2**

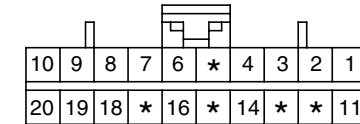

AMP\_040M2\_20F\_B

**M28**

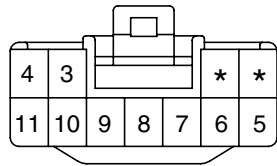

KET\_090II\_11F\_W

**M75**

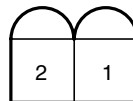

5264\_02\_MOLEX

**M76**

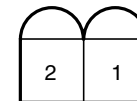

5264\_02\_MOLEX

**BLANK**

**AUTOMATIC TRANSAXLE CONTROL SYSTEM**

Automatic Transaxle Control System (G4FC-GSL 1.6L) (4)

**SD450-4**

**MEMO**

# AUTOMATIC TRANSAXLE CONTROL SYSTEM

## Automatic Transaxle Control System (G4KD-GSL 2.0L) (1)

SD450-5

### THETA II 2.0L

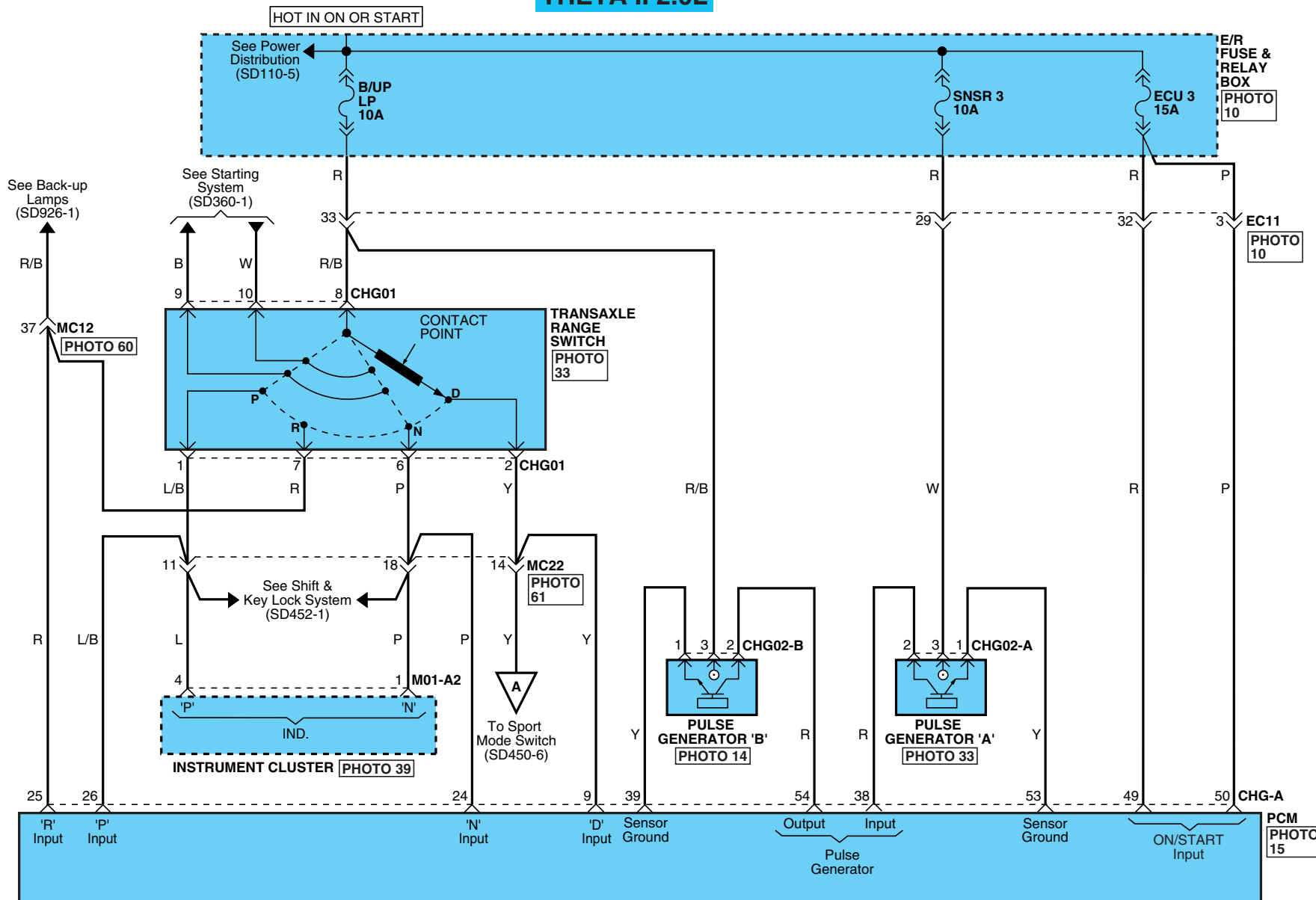



# AUTOMATIC TRANSAXLE CONTROL SYSTEM

## Automatic Transaxle Control System (G4KD-GSL 2.0L) (2)

SD450-6

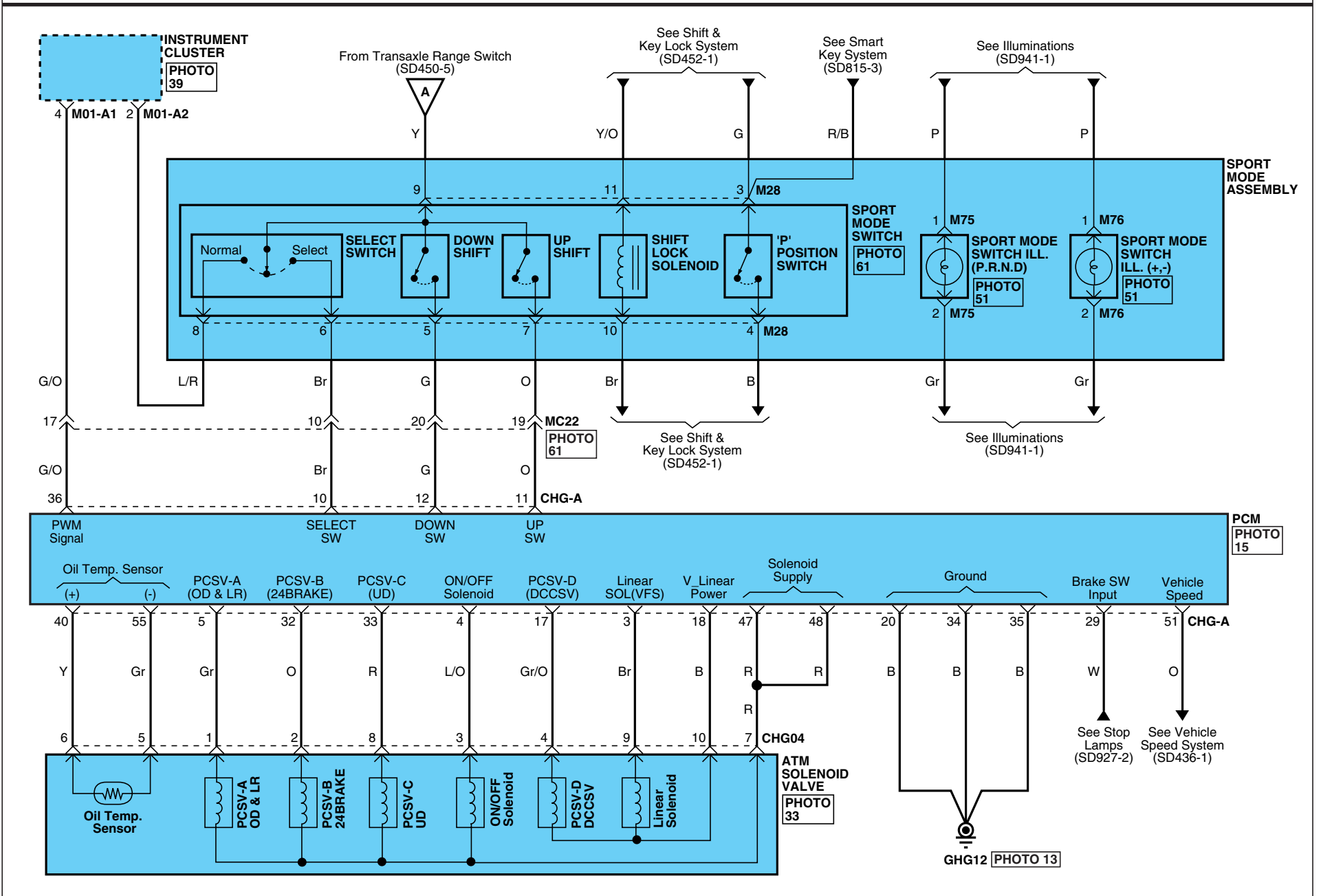

# AUTOMATIC TRANSAXLE CONTROL SYSTEM

## Automatic Transaxle Control System (G4KD-GSL 2.0L) (3)

SD450-7

**CHG-A**

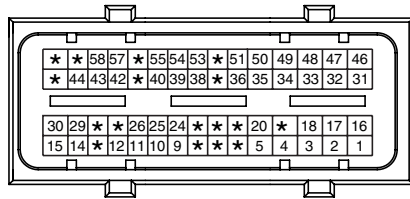

AMP\_ECU\_60F\_B\_A

**CHG01**



KET\_SSD\_10F\_B\_A

**CHG02-A**



KET\_SSD\_03F\_Gr\_B

**CHG02-B**

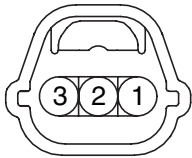

KET\_SSD\_03F\_B\_A

**CHG04**

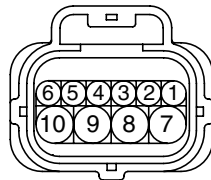

FCI\_FPC\_10F\_B

**M01-A1**

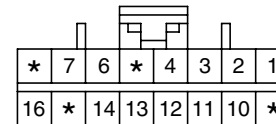

AMP\_040M2\_16F\_W

**M01-A2**

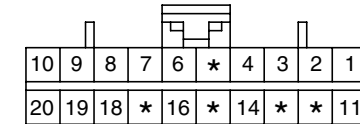

AMP\_040M2\_20F\_B

**M28**

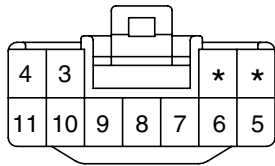

KET\_090II\_11F\_W

**M75**

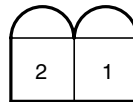

5264\_02\_MOLEX

**M76**

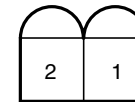

5264\_02\_MOLEX

**BLANK**

**AUTOMATIC TRANSAXLE CONTROL SYSTEM**

**Automatic Transaxle Control System (G4KD-GSL 2.0L) (4)**

**SD450-8**

**MEMO**

Shift & Key Lock System (1)

SD452-1

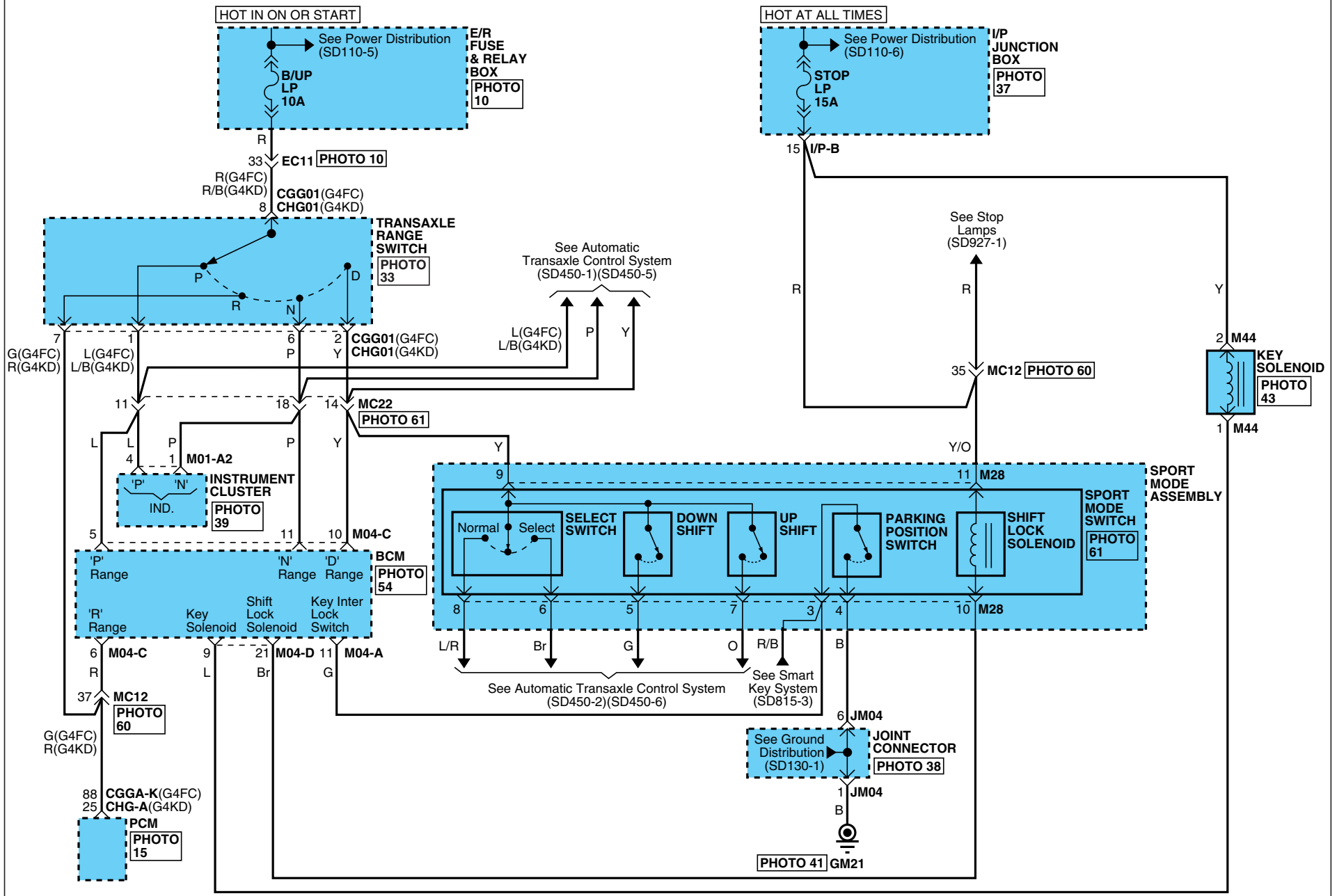

# SHIFT & KEY LOCK SYSTEM

## Shift & Key Lock System (2)

SD452-2

**CGGA-K**

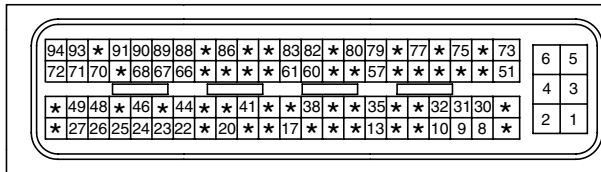

AMP\_ECU\_94F\_B

**CHG-A**

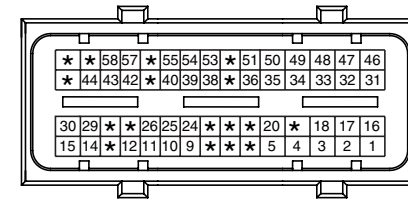

AMP\_ECU\_60F\_B\_A

**CGG01**



KET\_SSD\_10F\_B\_A

**CHG01**



KET\_SSD\_10F\_B\_A

**M01-A2**

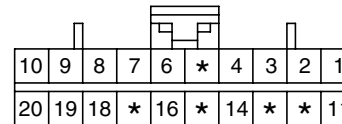

AMP\_040M2\_20F\_B

**M04-A**

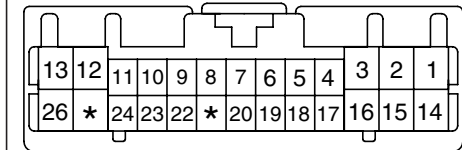

KET\_0407\_26F\_W

**M04-C**

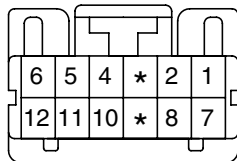

KET\_0407\_12F\_W

**M04-D**

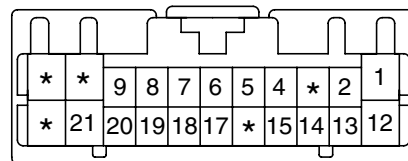

KET\_0407\_22F\_W

**M28**

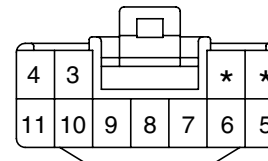

KET\_090II\_11F\_W

**M44**

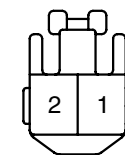

KET\_090II1\_02F\_B\_R

Motor Driven Power Steering (MDPS) System (1)

SD563-1

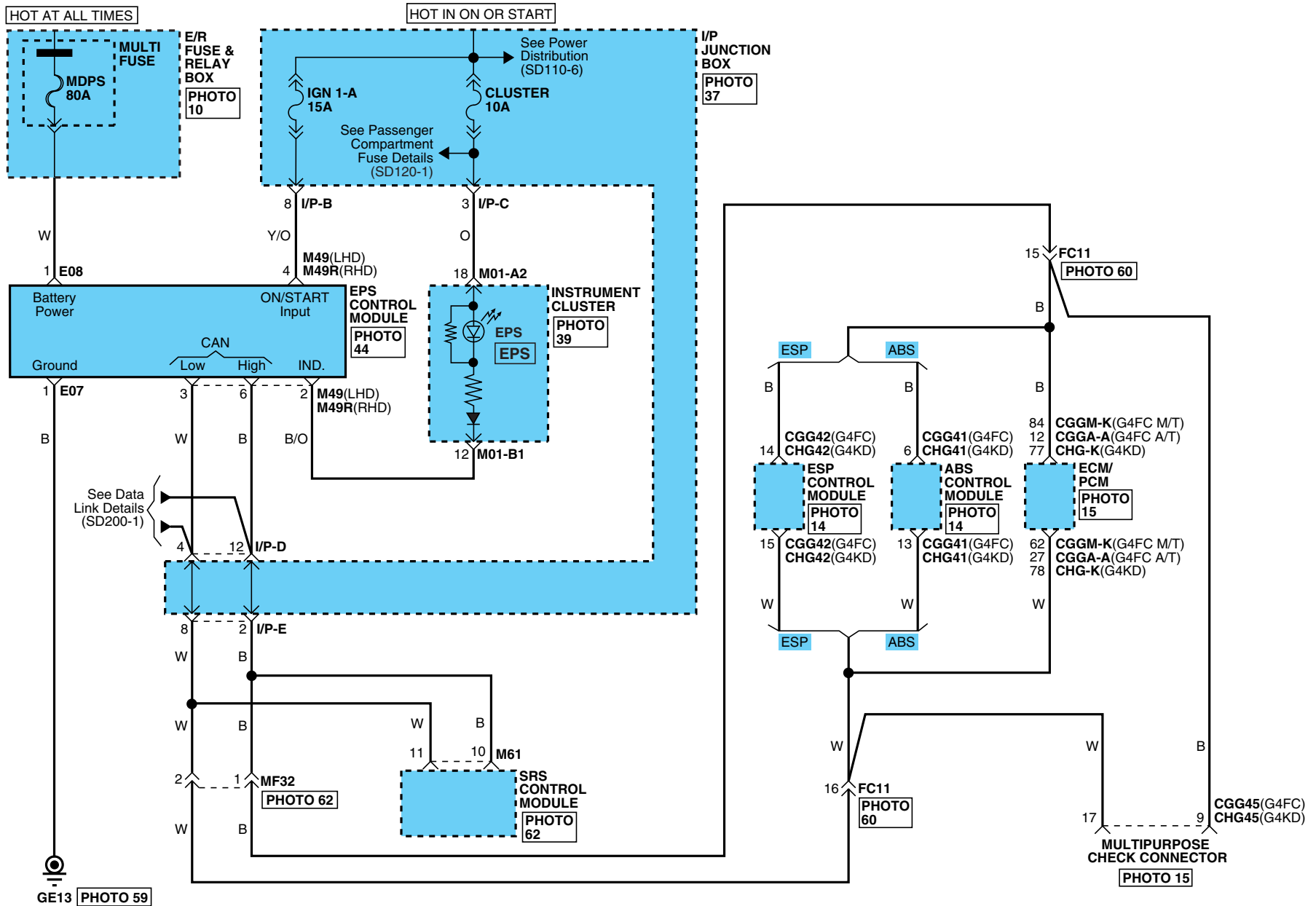

# MOTOR DRIVEN POWER STEERING (MDPS) SYSTEM

## Motor Driven Power Steering (MDPS) System (2)

SD563-2

**CGGA-A**

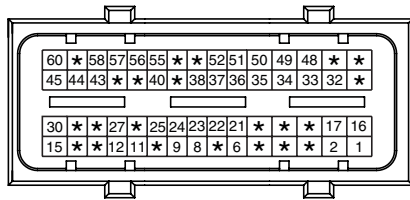

AMP\_ECU\_60F\_B

**CGGM-K**

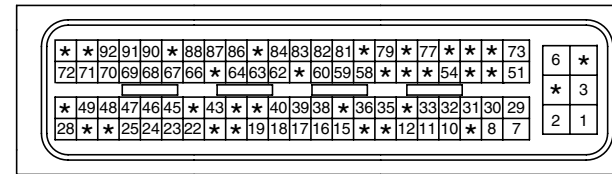

AMP\_ECU\_94F\_B

**CGG41/CHG41**

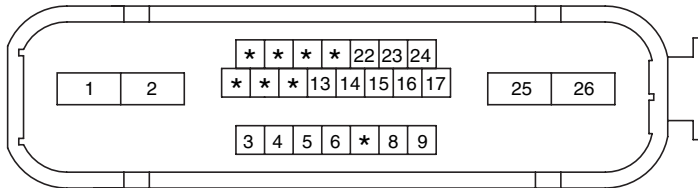

AMP\_ABS\_26F\_B

**CGG42/CHG42**

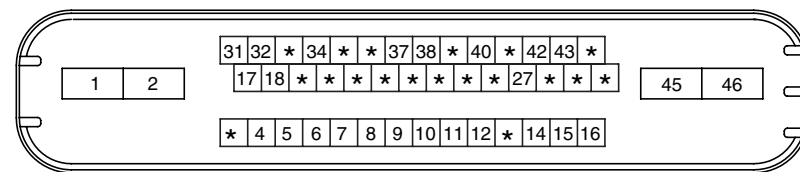

AMP\_ESP\_46F\_B

**CGG45**

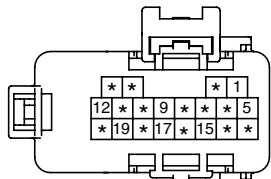

KET\_DIAG\_20F\_B\_BRK\_C

**CHG45**

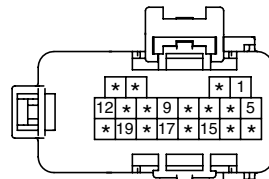

KET\_DIAG\_20F\_B\_BRK\_C

**CHG-K**

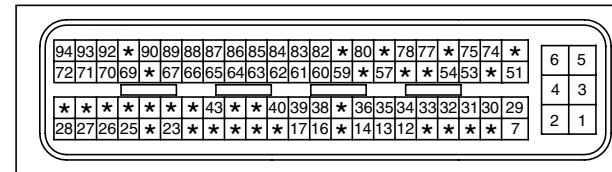

AMP\_ECU\_94F\_B

**E07**

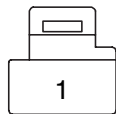

KET\_58L\_01F\_W

**E08**

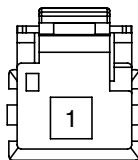

KET\_375\_01F\_B

**M01-A2**

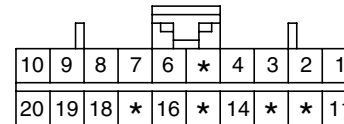

AMP\_040M2\_20F\_B

**M01-B1**

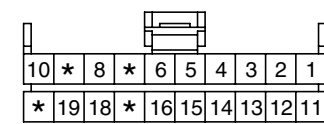

AMP\_040M1\_20F\_B

**M49**

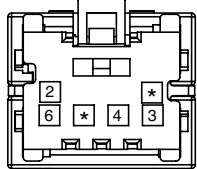

KET\_040III\_06F\_W

**M49R**

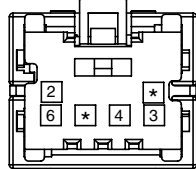

KET\_040III\_06F\_W

**M61**

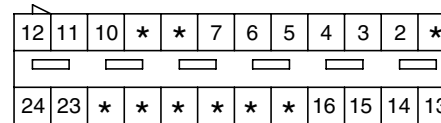

AMP\_ABG\_24F\_Y\_ECU\_TD

**BLANK**

Supplemental Restraint System (SRS) (1)

SD569-1

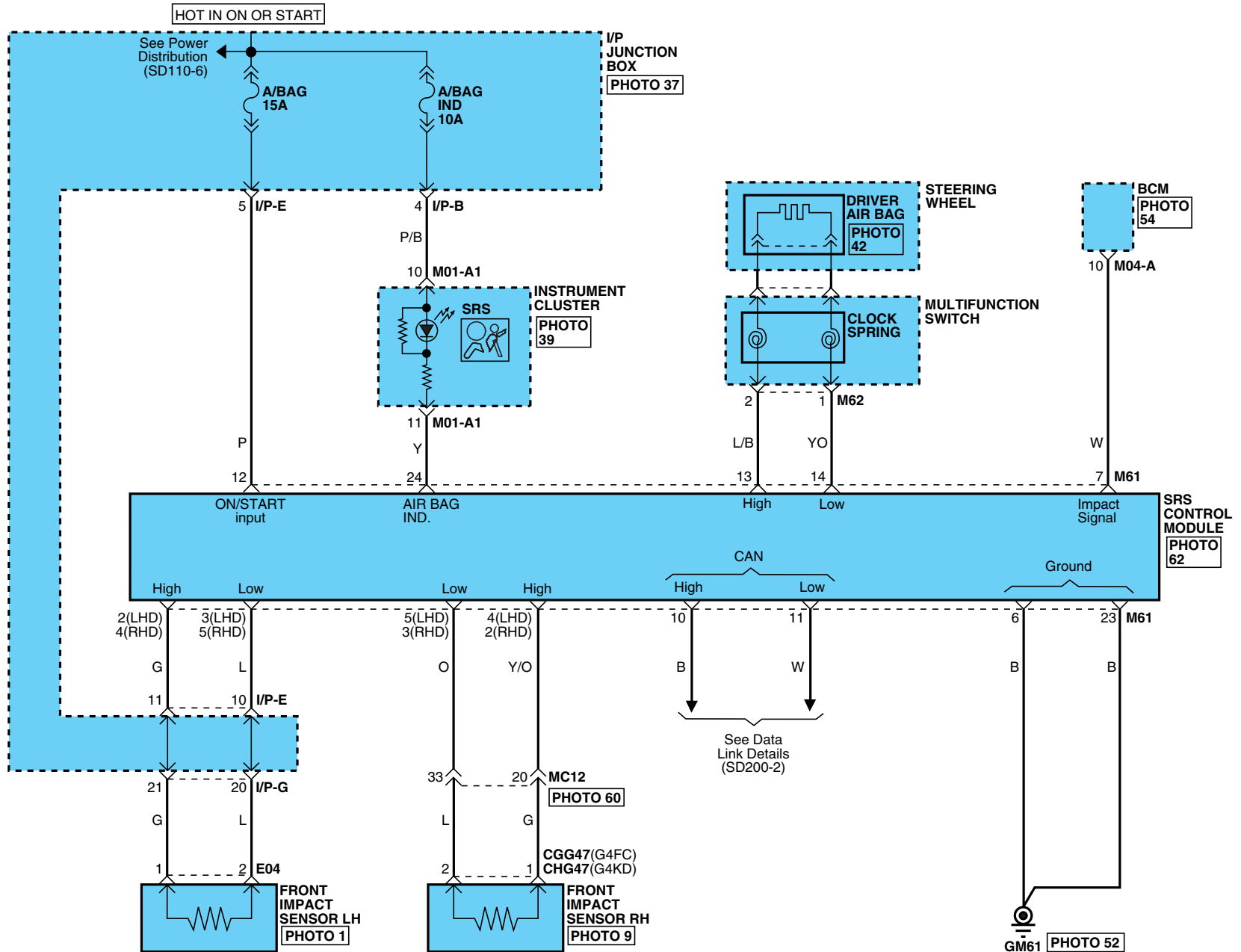





# SUPPLEMENTAL RESTRAINT SYSTEM (SRS)

## Supplemental Restraint System (SRS) (2)

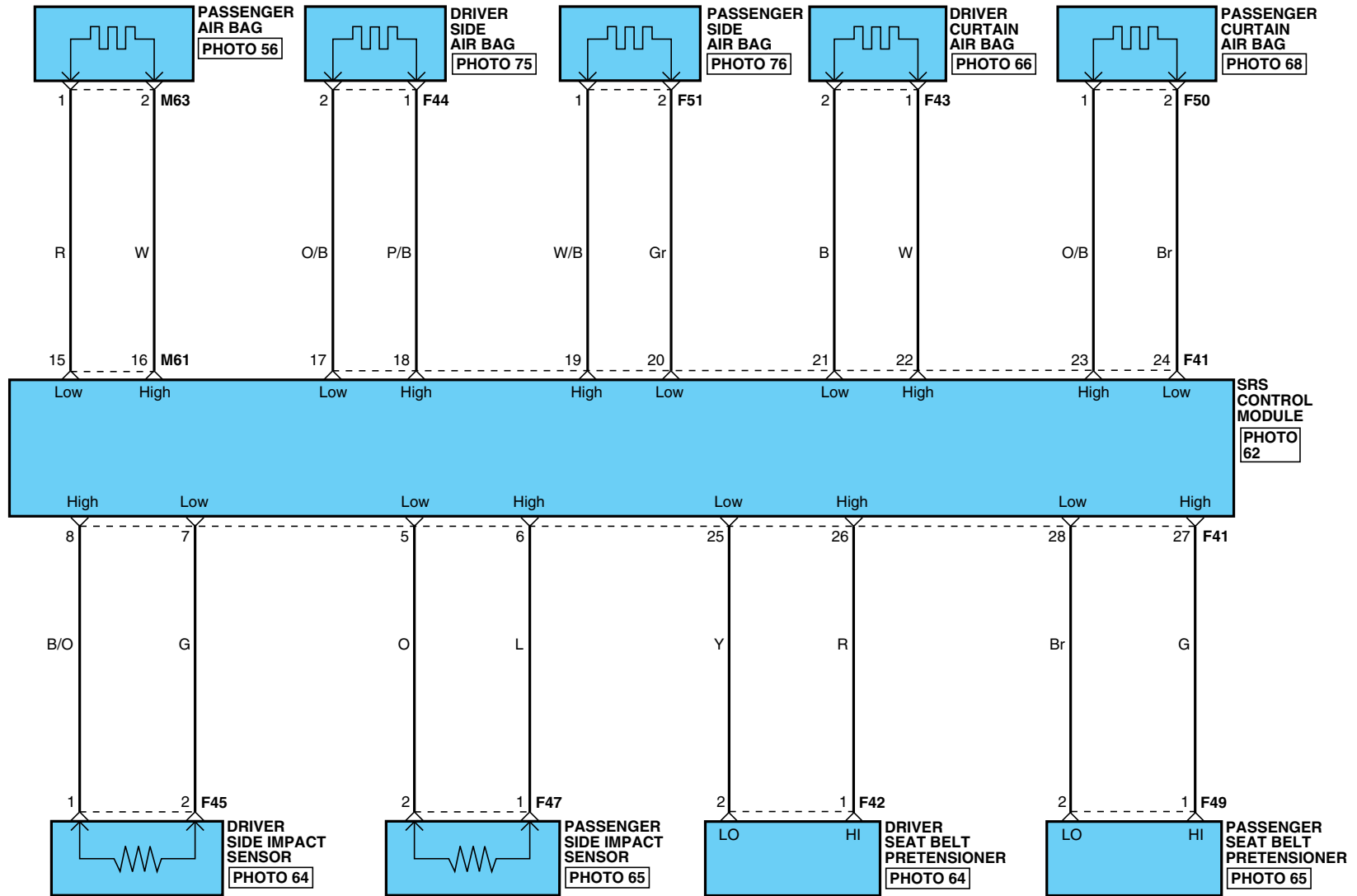
SD569-2

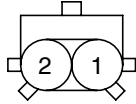
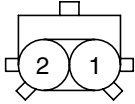
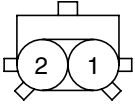
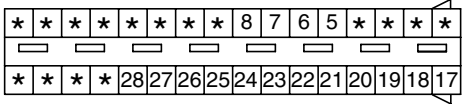
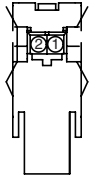
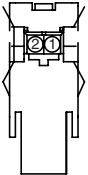
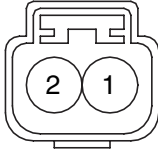
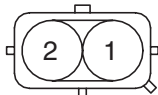
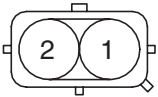
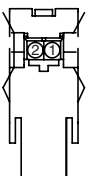
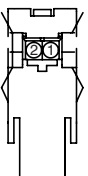

# SUPPLEMENTAL RESTRAINT SYSTEM (SRS)

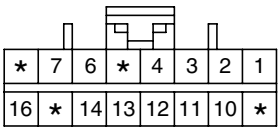
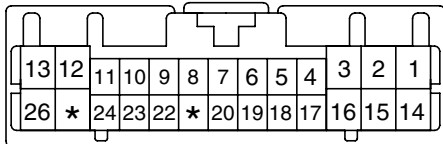
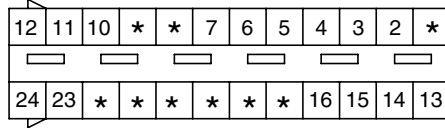
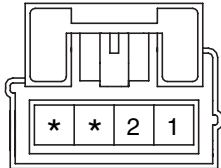
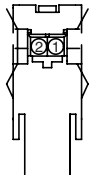
Supplemental Restraint System (SRS) (3)			SD569-3
<p><b>CGG47</b></p>  <p>YAZ_ABG_02F_Y_GH</p>	<p><b>CHG47</b></p>  <p>YAZ_ABG_02F_Y_GH</p>	<p><b>E04</b></p>  <p>YAZ_ABG_02F_Y_GH</p>	<p><b>F41</b></p>  <p>AMP_ABG_32F_Y_ECU_TD</p>
<p><b>F42</b></p>  <p>JST_SQH_02F_B</p>	<p><b>F43</b></p>  <p>JST_SQH_02F_B</p>	<p><b>F44</b></p>  <p>YAZ_040WP_02F_Y_GH</p>	<p><b>F45</b></p>  <p>YAZ_040_02F_Y</p>
<p><b>F47</b></p>  <p>YAZ_040_02F_Y</p>	<p><b>F49</b></p>  <p>JST_SQH_02F_B</p>	<p><b>F50</b></p>  <p>JST_SQH_02F_B</p>	<p><b>F51</b></p>  <p>YAZ_040WP_02F_Y_GH</p>
<p><b>M01-A1</b></p>  <p>AMP_040M2_16F_W</p>	<p><b>M04-A</b></p>  <p>KET_0407_26F_W</p>	<p><b>M61</b></p>  <p>AMP_ABG_24F_Y_ECU_TD</p>	<p><b>M62</b></p>  <p>YAZ_040_04F_Y</p>
<p><b>M63</b></p>  <p>JST_SQH_02F_B</p>	<p><b>BLANK</b></p>	<p><b>BLANK</b></p>	<p><b>BLANK</b></p>

**SUPPLEMENTAL RESTRAINT SYSTEM (SRS)**

**Supplemental Restraint System (SRS) (4)**

**SD569-4**

**MEMO**

# ANTI-LOCK BRAKE SYSTEM (ABS)

E474D339

## Anti-Lock Brake System (ABS) (1)

SD587-1

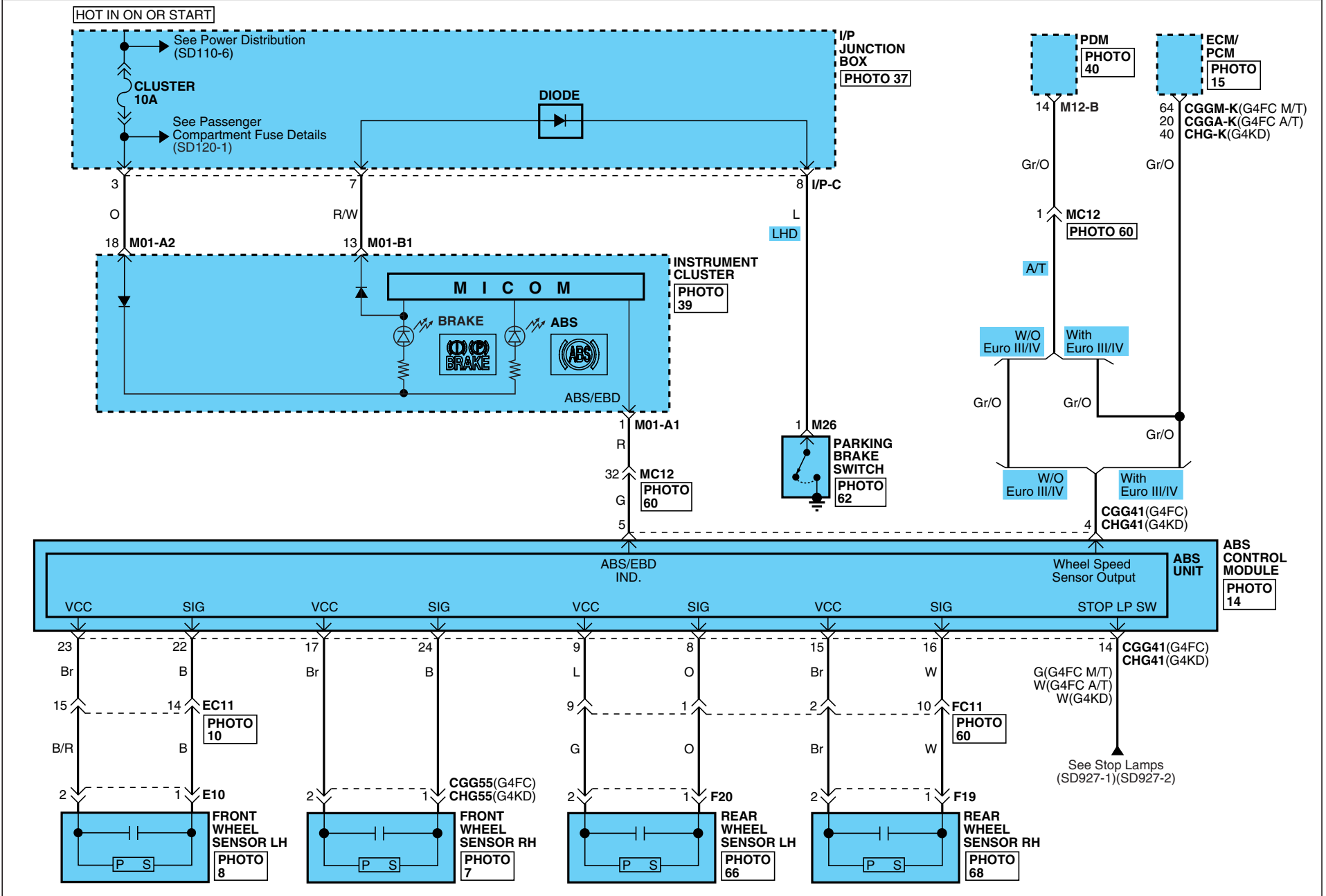

# ANTI-LOCK BRAKE SYSTEM (ABS)

## Anti-Lock Brake System (ABS) (2)

SD587-2

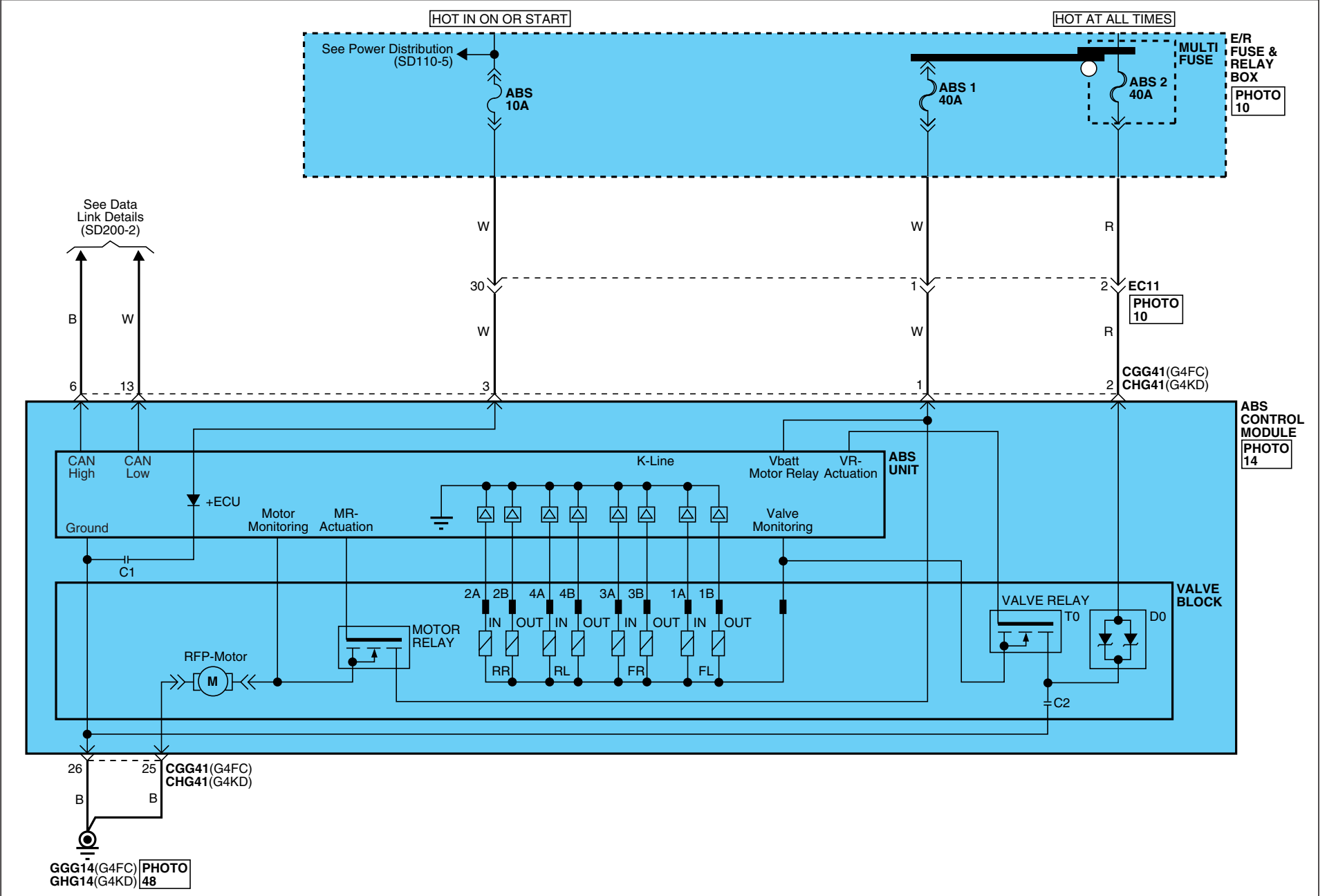

# ANTI-LOCK BRAKE SYSTEM (ABS)

## Anti-Lock Brake System (ABS) (3)

SD587-3

**CGGA-K**

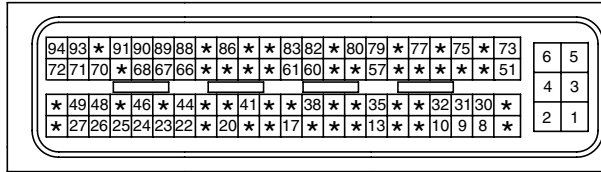

AMP\_ECU\_94F\_B

**CGGM-K**

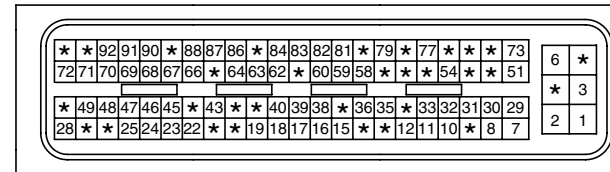

AMP\_ECU\_94F\_B

**CGG41**

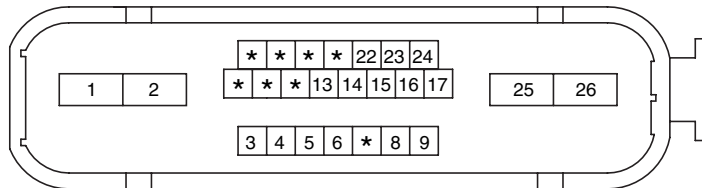

AMP\_ABS\_26F\_B

**CGG55**

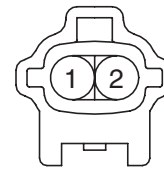

KET\_090IWP\_02M\_Gr

**BLANK**

**CHG-K**

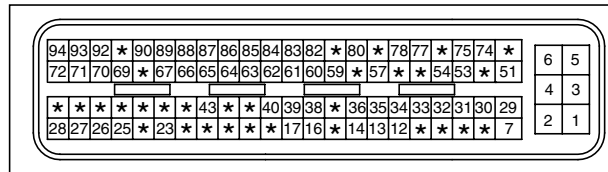

AMP\_ECU\_94F\_B

**CHG41**

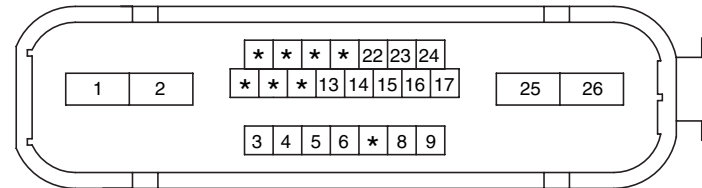

AMP\_ABS\_26F\_B

**CHG55**

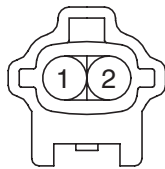

KET\_090IWP\_02M\_Gr

**E10**

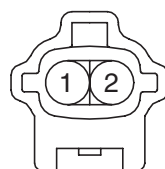

KET\_090IWP\_02M\_Gr

**F19**

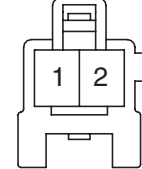

KET\_090III\_02M\_W\_L\_1

**F20**

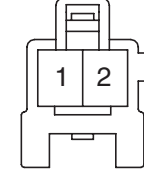

KET\_090III\_02M\_W\_L\_1

**M01-A1**

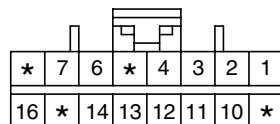

AMP\_040M2\_16F\_W

**M01-A2**

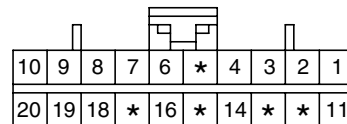

AMP\_040M2\_20F\_B

**M01-B1**

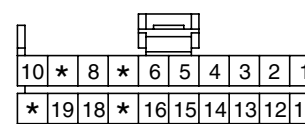

AMP\_040M1\_20F\_B

**M12-B**

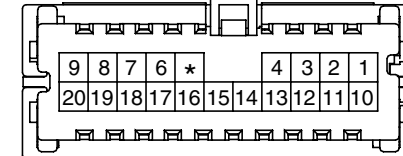

KET\_040III\_20F\_W

# ANTI-LOCK BRAKE SYSTEM (ABS)

Anti-Lock Brake System (ABS) (4) SD587-4

M26

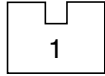

AMP\_250DL\_01F\_B

BLANK

BLANK

BLANK

# ELECTRONIC STABILITY PROGRAM (ESP) SYSTEM

EB53DC54

## Electronic Stability Program (ESP) System (1)

SD588-1

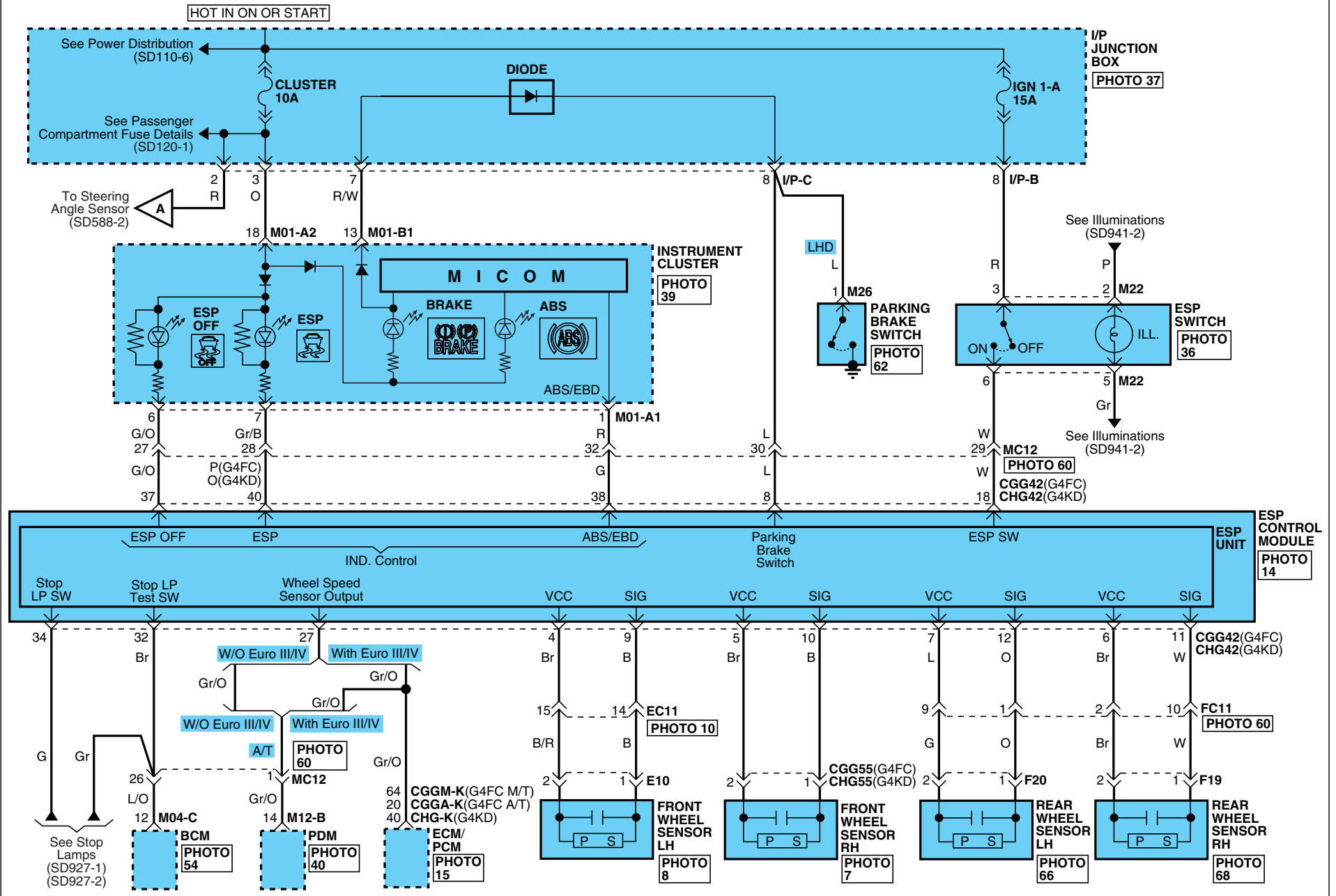



# ELECTRONIC STABILITY PROGRAM (ESP) SYSTEM

## Electronic Stability Program (ESP) System (2)

SD588-2

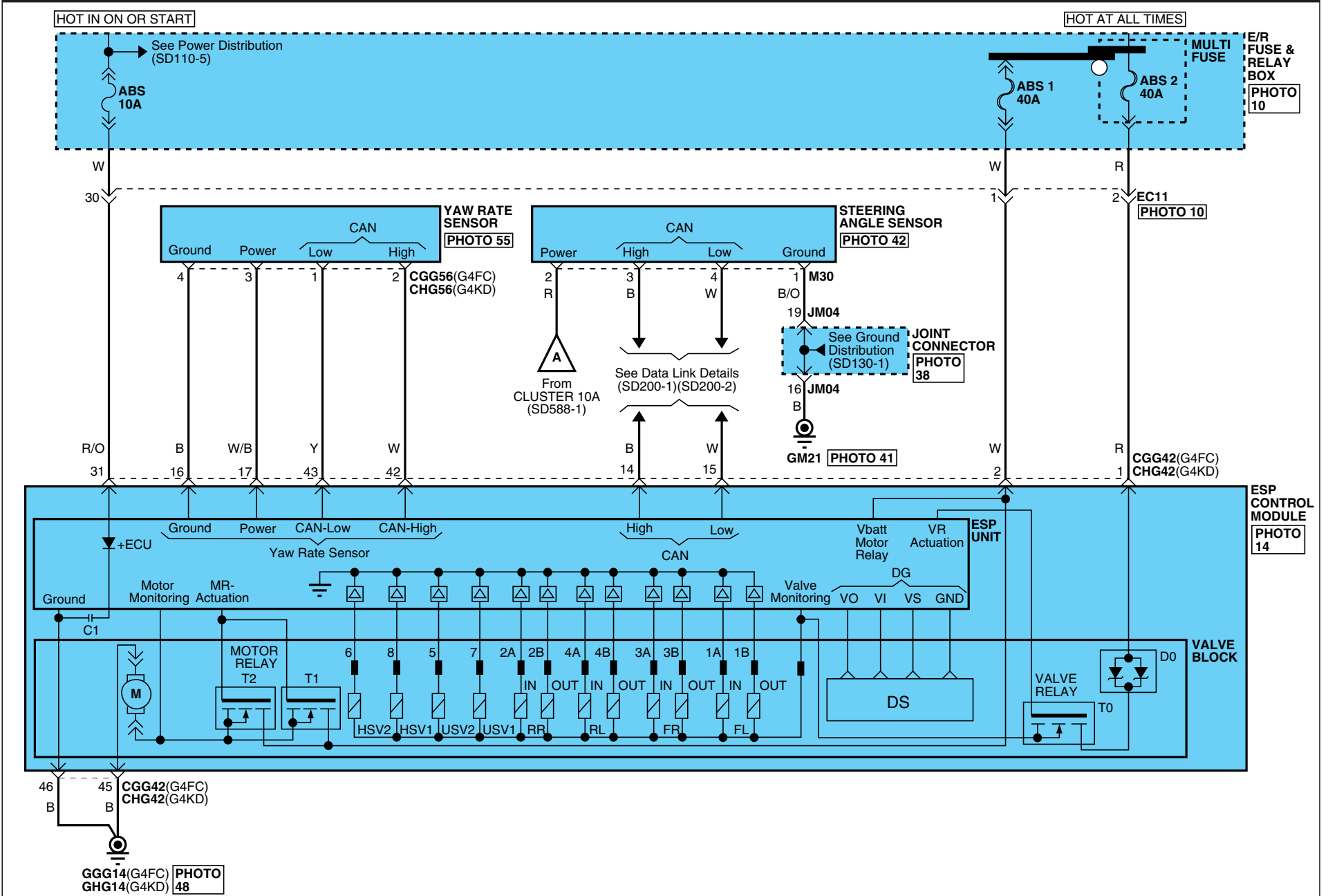

# ELECTRONIC STABILITY PROGRAM (ESP) SYSTEM

## Electronic Stability Program (ESP) System (3)

SD588-3

**CGGA-K**

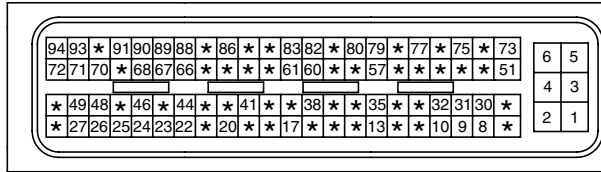

AMP\_ECU\_94F\_B

**CGGM-K**

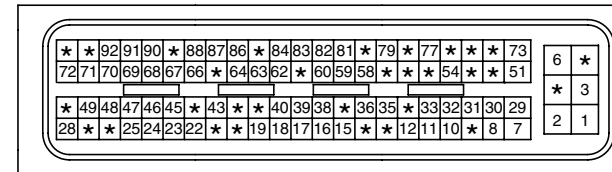

AMP\_ECU\_94F\_B

**CGG42**

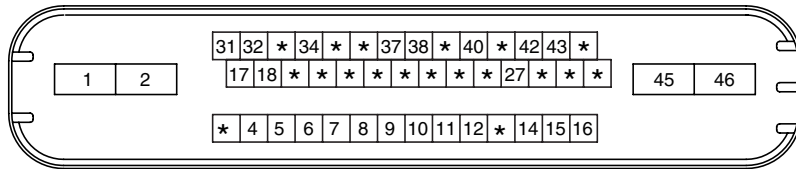

AMP\_ESP\_46F\_B

**CGG55**

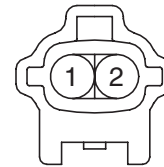

KET\_090IWP\_02M\_Gr

**CGG56**

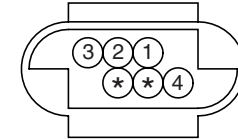

AMP\_MQSWP\_06F\_B\_1

**CHG-K**

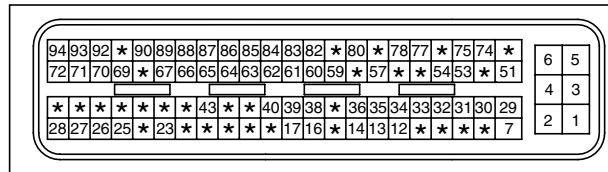

AMP\_ECU\_94F\_B

**CHG42**

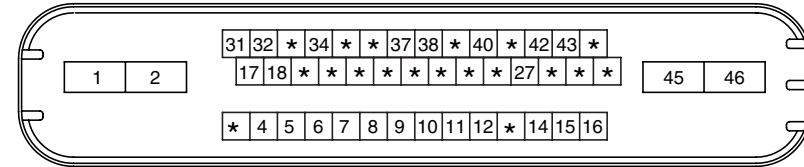

AMP\_ESP\_46F\_B

**CHG55**

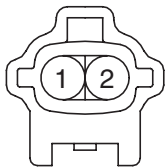

KET\_090IWP\_02M\_Gr

**CHG56**

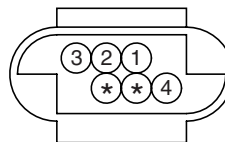

AMP\_MQSWP\_06F\_B\_1

**E10**

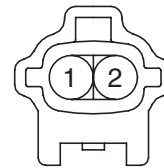

KET\_090IWP\_02M\_Gr

**F19**

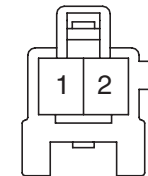

KET\_090III\_02M\_W\_L\_1

**F20**

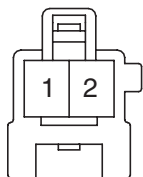

KET\_090III\_02M\_W\_L\_1

**M01-A1**

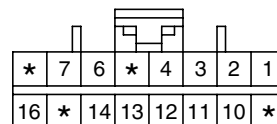

AMP\_040M2\_16F\_W

**M01-A2**

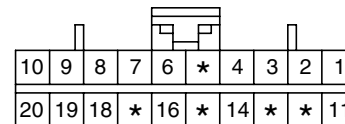

AMP\_040M2\_20F\_B

**M01-B1**

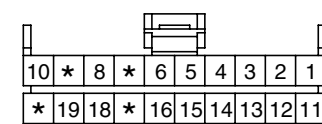

AMP\_040M1\_20F\_B

# ELECTRONIC STABILITY PROGRAM (ESP) SYSTEM

## Electronic Stability Program (ESP) System (4)

SD588-4

**M04-C**

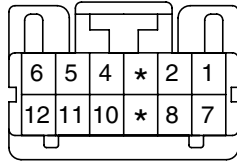

KET\_0407\_12F\_W

**M12-B**

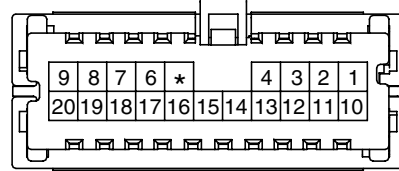

KET\_040III\_20F\_W

**M22**

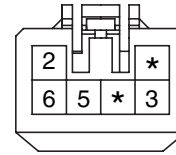

AMP\_090III\_06F\_Y

**M26**

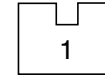

AMP\_250DL\_01F\_B

**M30**

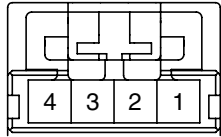

AMP\_MQS\_04F\_Y\_040

**BLANK**

**BLANK**

**BLANK**

Power Door Locks (1)

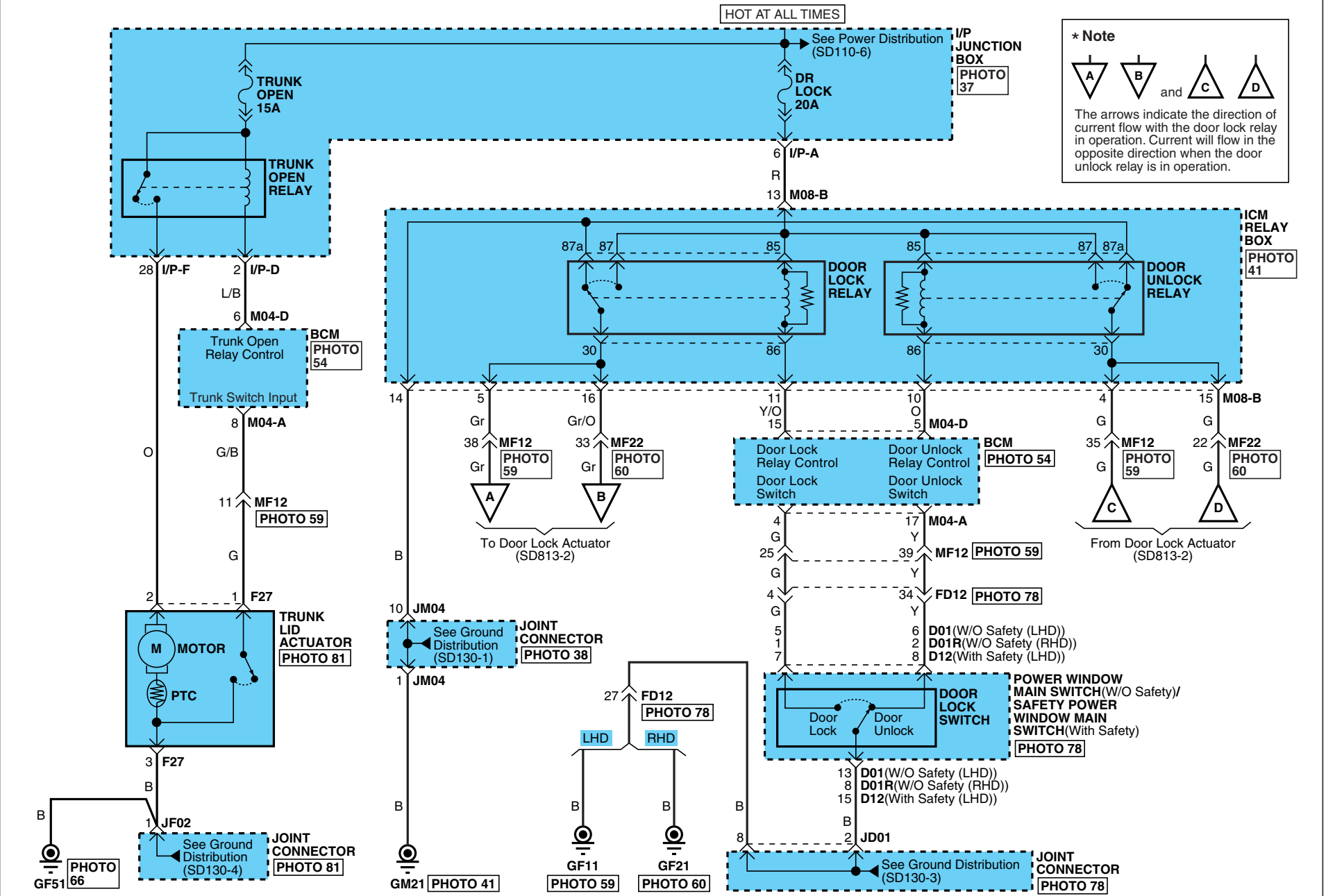

# POWER DOOR LOCKS

## Power Door Locks (2)

SD813-2

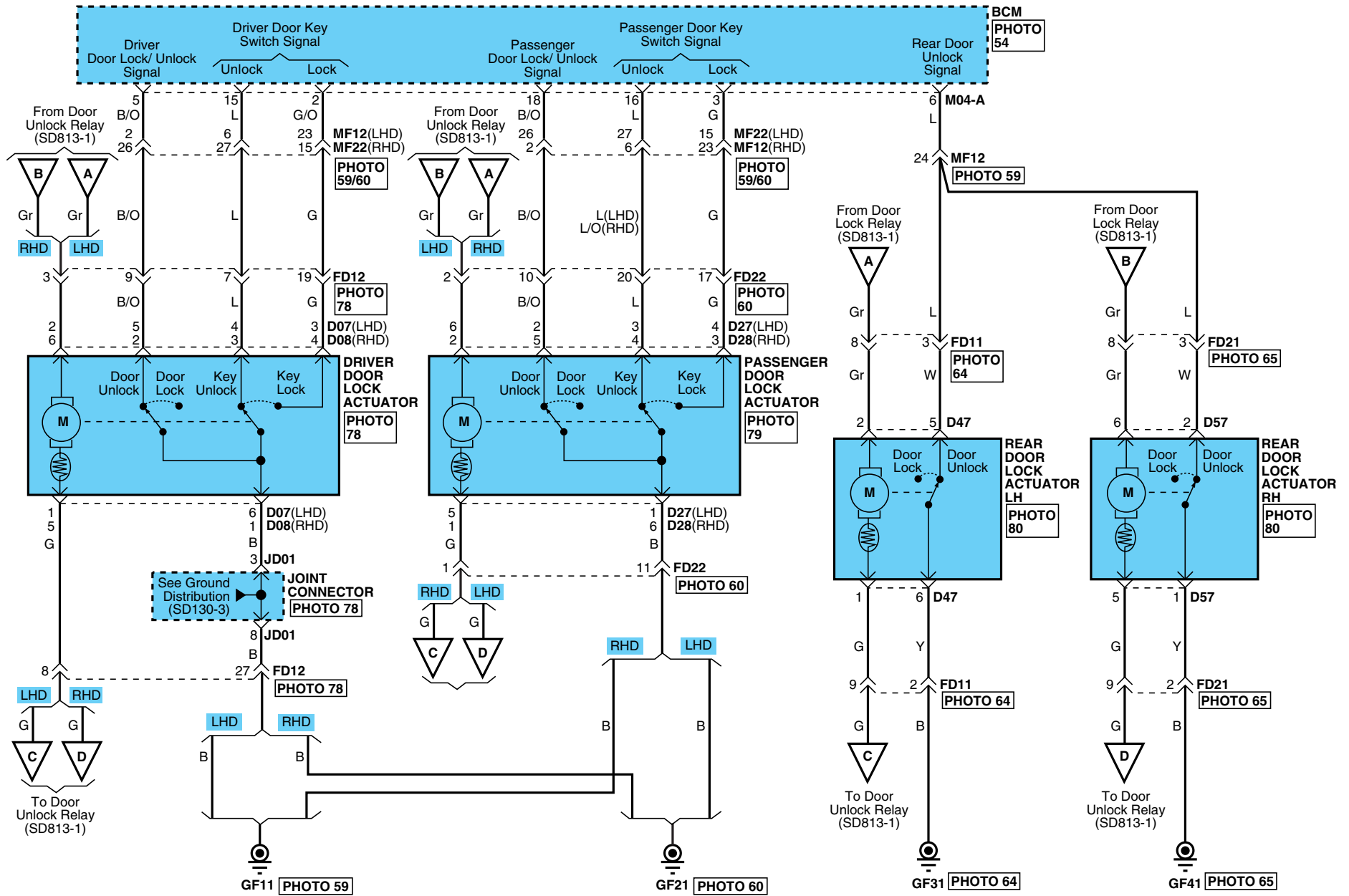

# POWER DOOR LOCKS

## Power Door Locks (3)

SD813-3

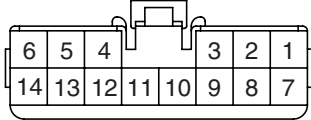
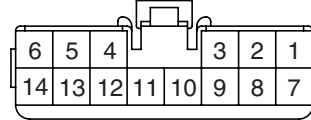
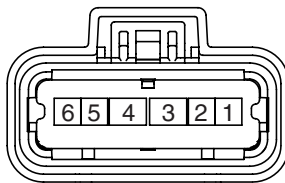
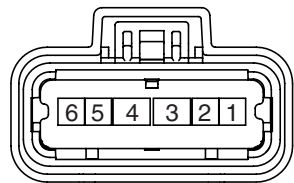
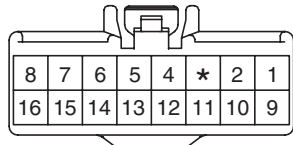
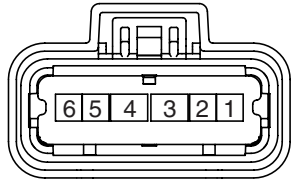
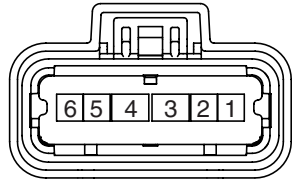
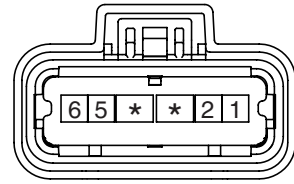
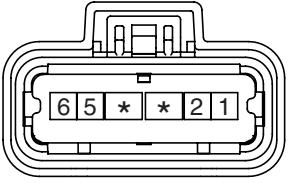
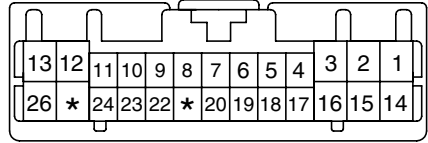
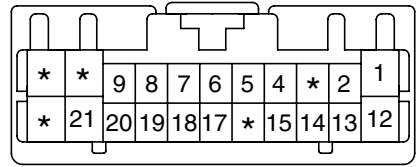
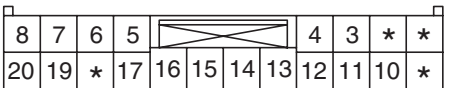
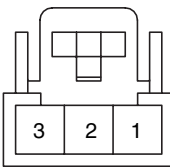
<p style="text-align: center;"><b>D01</b></p>  <p style="text-align: center;">KET_090II_14F_W</p>	<p style="text-align: center;"><b>D01R</b></p>  <p style="text-align: center;">KET_090II_14F_W</p>	<p style="text-align: center;"><b>D07</b></p>  <p style="text-align: center;">FCI_MINIWP_06F_B</p>	<p style="text-align: center;"><b>D08</b></p>  <p style="text-align: center;">FCI_MINIWP_06F_B</p>
<p style="text-align: center;"><b>D12</b></p>  <p style="text-align: center;">KET_090III_16F_W</p>	<p style="text-align: center;"><b>D27</b></p>  <p style="text-align: center;">FCI_MINIWP_06F_B</p>	<p style="text-align: center;"><b>D28</b></p>  <p style="text-align: center;">FCI_MINIWP_06F_B</p>	<p style="text-align: center;"><b>D47</b></p>  <p style="text-align: center;">FCI_MINIWP_06F_B</p>
<p style="text-align: center;"><b>D57</b></p>  <p style="text-align: center;">FCI_MINIWP_06F_B</p>	<p style="text-align: center;"><b>M04-A</b></p>  <p style="text-align: center;">KET_0407_26F_W</p>	<p style="text-align: center;"><b>M04-D</b></p>  <p style="text-align: center;">KET_0407_22F_W</p>	<p style="text-align: center;"><b>M08-B</b></p>  <p style="text-align: center;">AMP_0925_20F_W</p>
<p style="text-align: center;"><b>F27</b></p>  <p style="text-align: center;">AMP_070_03F_W_HOR</p>	<p style="text-align: center;"><b>BLANK</b></p>	<p style="text-align: center;"><b>BLANK</b></p>	<p style="text-align: center;"><b>BLANK</b></p>

**POWER DOOR LOCKS**

**Power Door Locks (4)**

**SD813-4**

**MEMO**

Smart Key System (1)

SD815-1

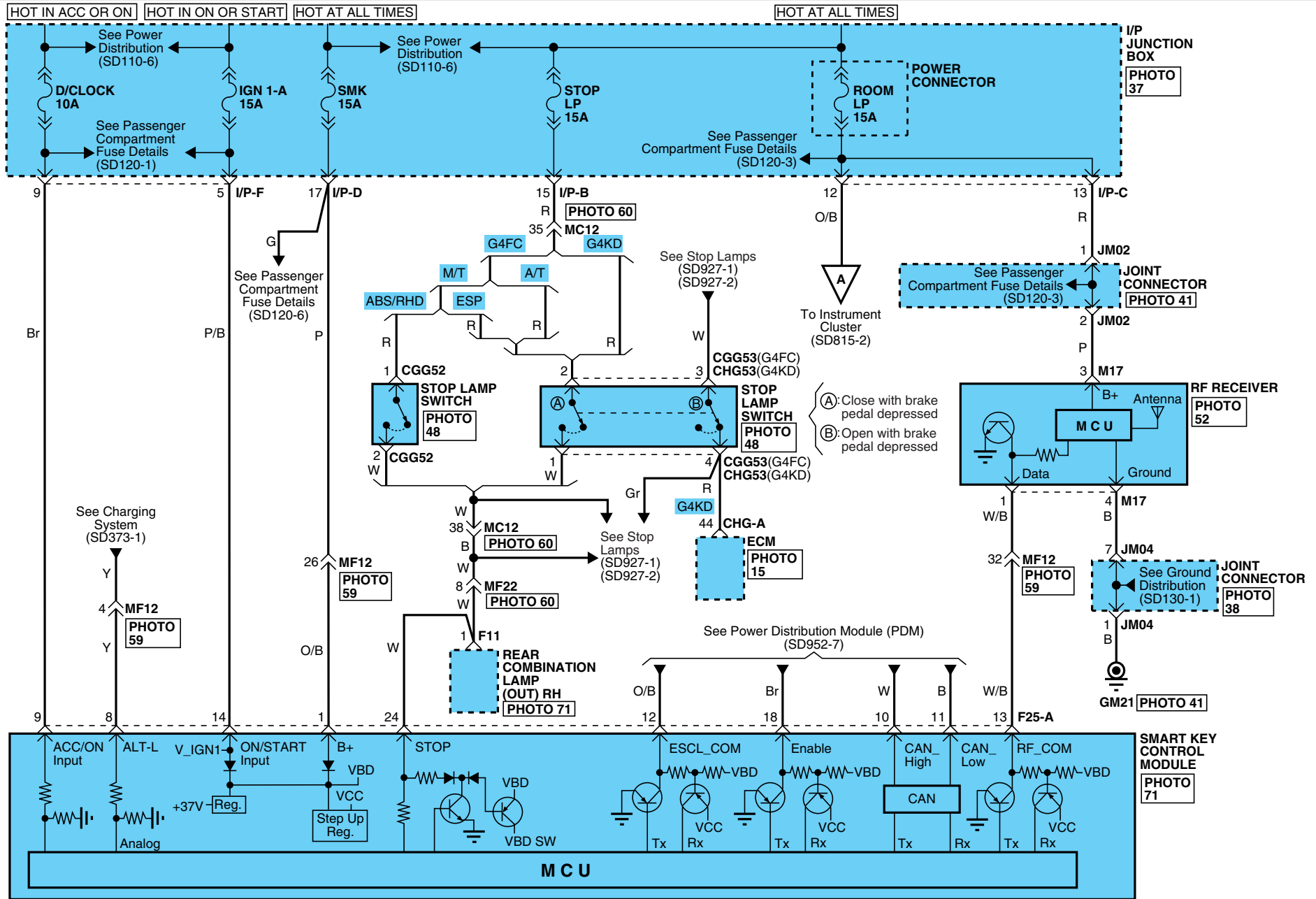



# SMART KEY SYSTEM

## Smart Key System (2)

SD815-2

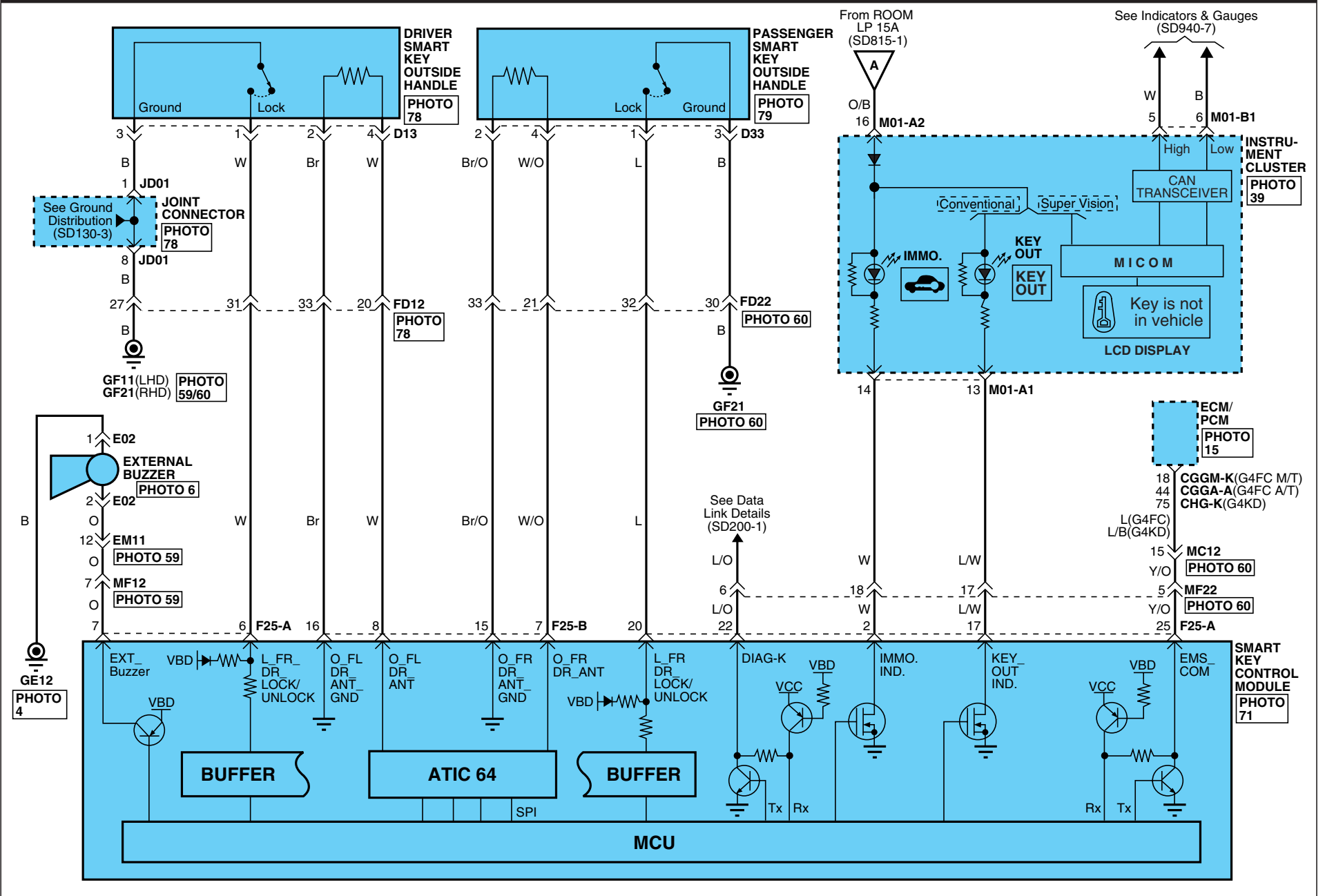

# SMART KEY SYSTEM

## Smart Key System (3)

SD815-3

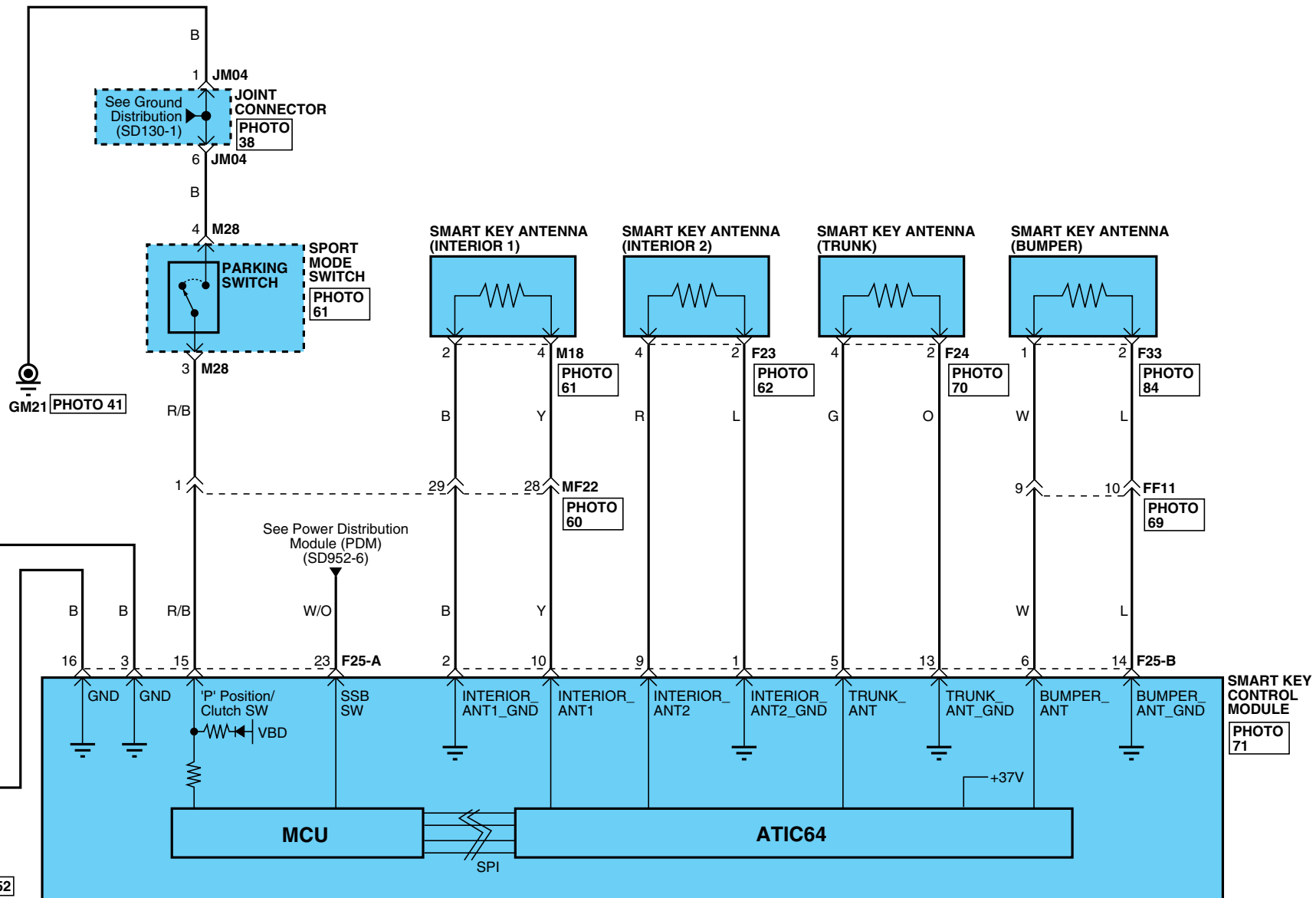

# SMART KEY SYSTEM

## Smart Key System (4)

SD815-4

**CGGA-A**

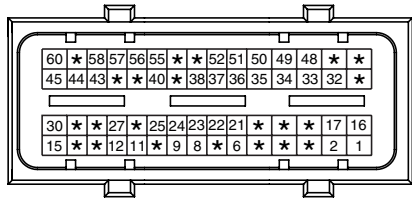

AMP\_ECU\_60F\_B

**CGGM-K**

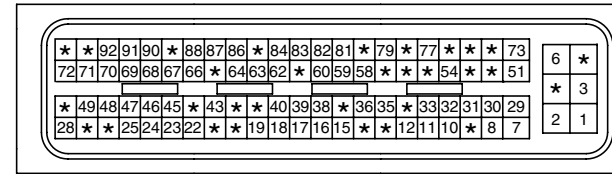

AMP\_ECU\_94F\_B

**CGG52**

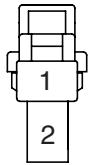

KET\_250DL\_02F\_B

**CGG53**

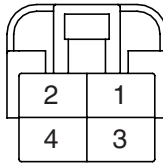

KET\_250DL\_04F\_W

**CHG-A**

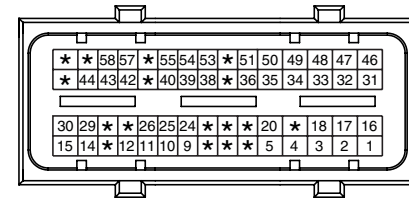

AMP\_ECU\_60F\_B\_A

**CHG-K**

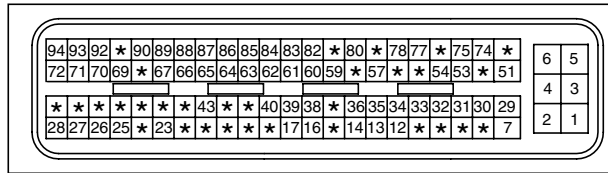

AMP\_ECU\_94F\_B

**CHG53**

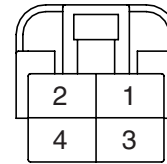

KET\_250DL\_04F\_W

**D13**

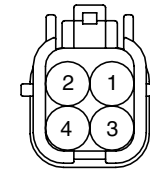

KET\_SWP\_04F\_B

**D33**

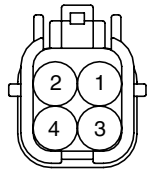

KET\_SWP\_04F\_B

**E02**

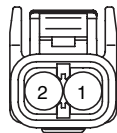

KET\_090IWP\_02F\_B\_ASM

**F11**

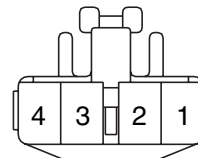

KET\_090I\_04F\_W

**F23**

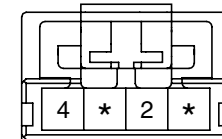

AMP\_MQS\_04F\_B\_040

**F24**

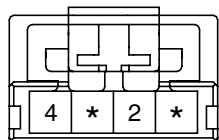

AMP\_MQS\_04F\_B\_040

**F25-A**

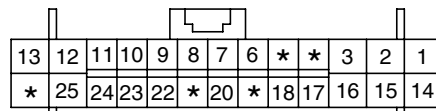

AMP\_0407\_26F\_W\_HD

**F25-B**

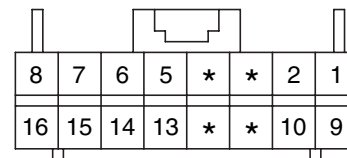

AMP\_0407\_16F\_W\_040

**F33**

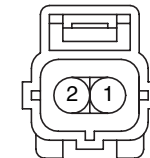

AMP\_EJWP\_02F\_B

# SMART KEY SYSTEM

## Smart Key System (5)

SD815-5

**M01-A1**

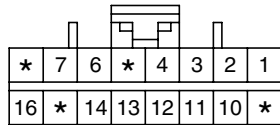

AMP\_040M2\_16F\_W

**M01-B1**

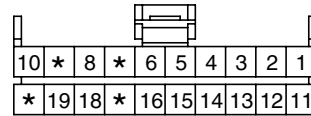

AMP\_040M1\_20F\_B

**M01-A2**

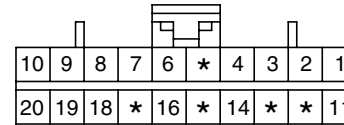

AMP\_040M2\_20F\_B

**M17**

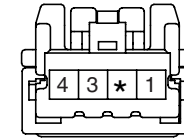

KET\_040III\_04F\_W

**M18**

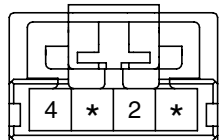

AMP\_MQS\_04F\_B\_040

**M28**

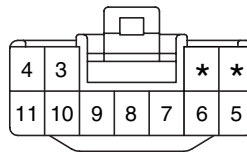

KET\_090II\_11F\_W

**BLANK**

**BLANK**

**SMART KEY SYSTEM**

**Smart Key System (6)**

**SD815-6**

**MEMO**

Sunroof (1)

SD816-1

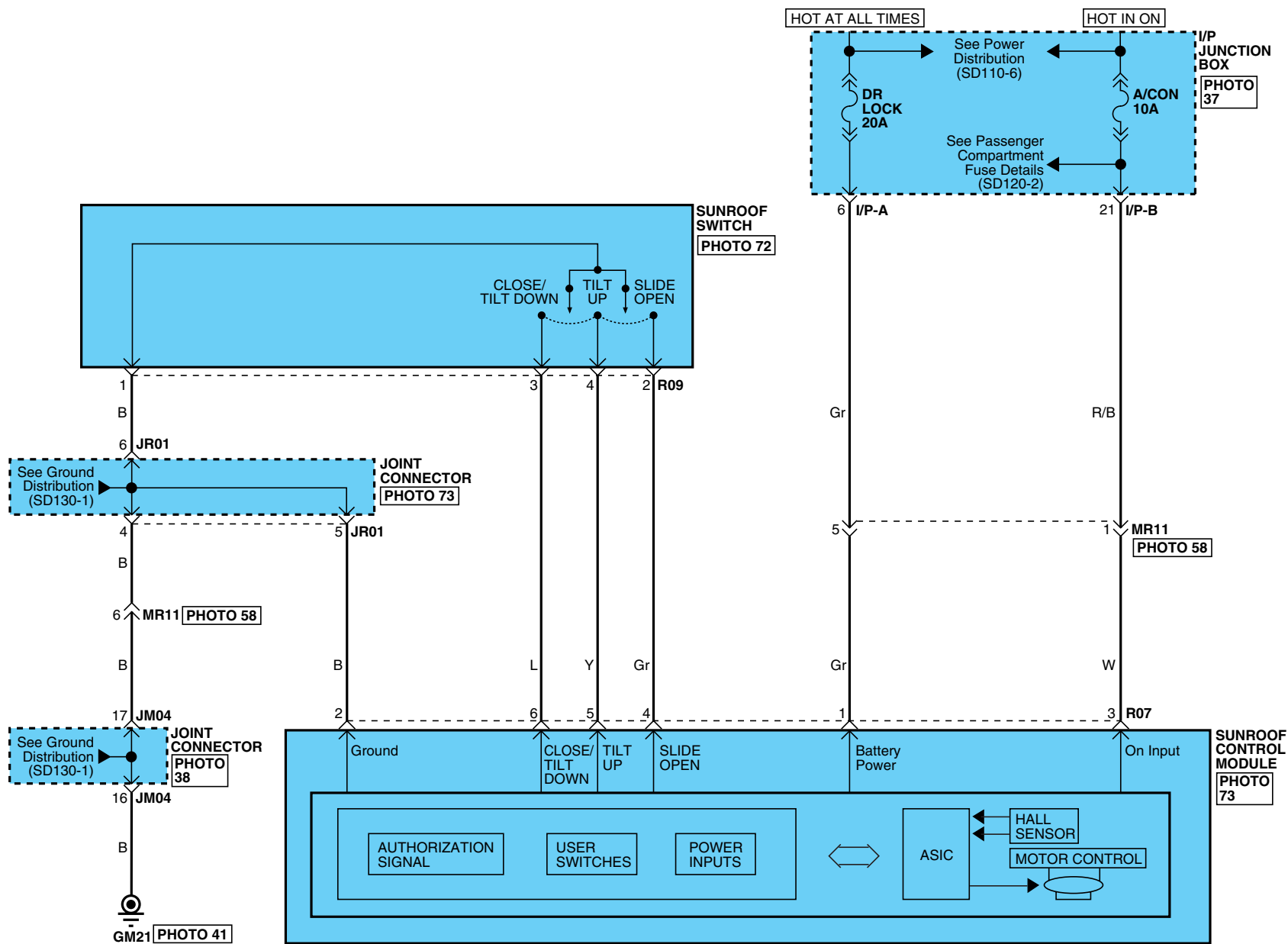

# SUNROOF

Sunroof (2)

SD816-2

R07

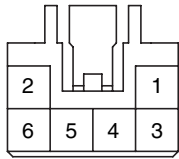

KET\_ASC\_06F\_W

R09

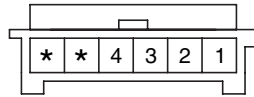

AMP\_MQS\_06F\_B

BLANK

BLANK

Power Windows (1)

SD824-1

With Safety Power Window & LHD

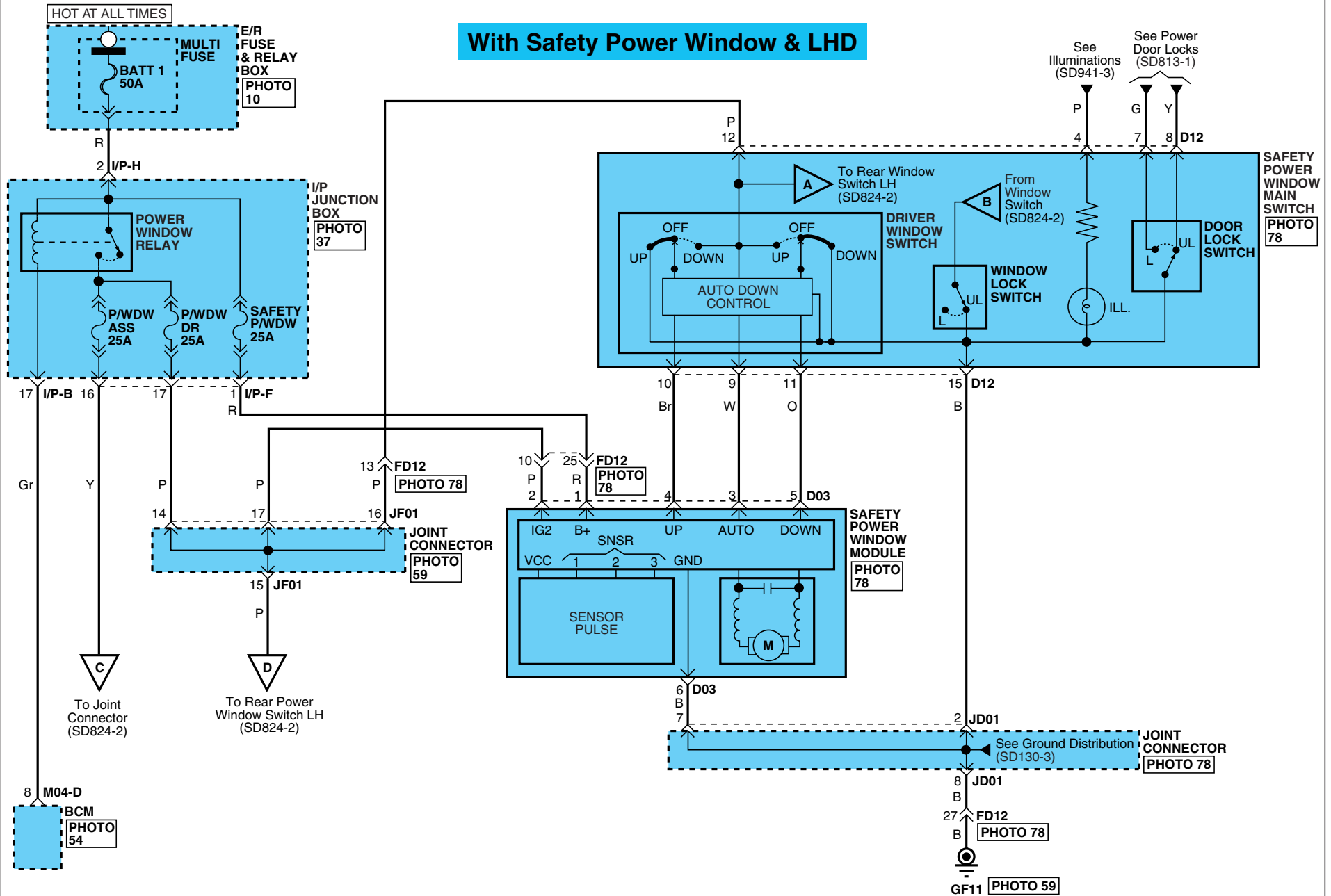



# POWER WINDOWS

## Power Windows (2)

SD824-2

### With Safety Power Window & LHD

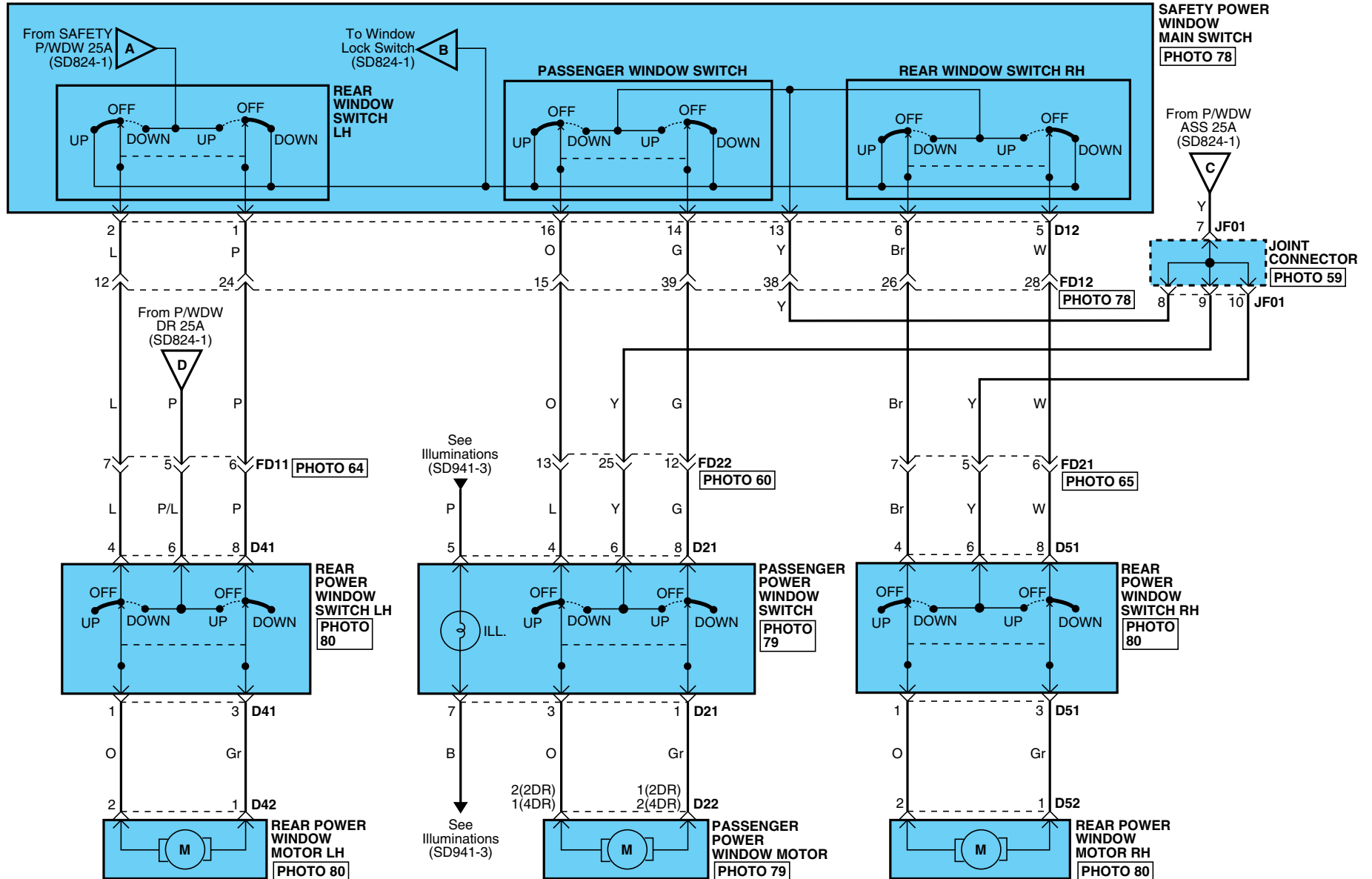

# POWER WINDOWS

## Power Windows (3)

SD824-3

### W/O Safety Power Window

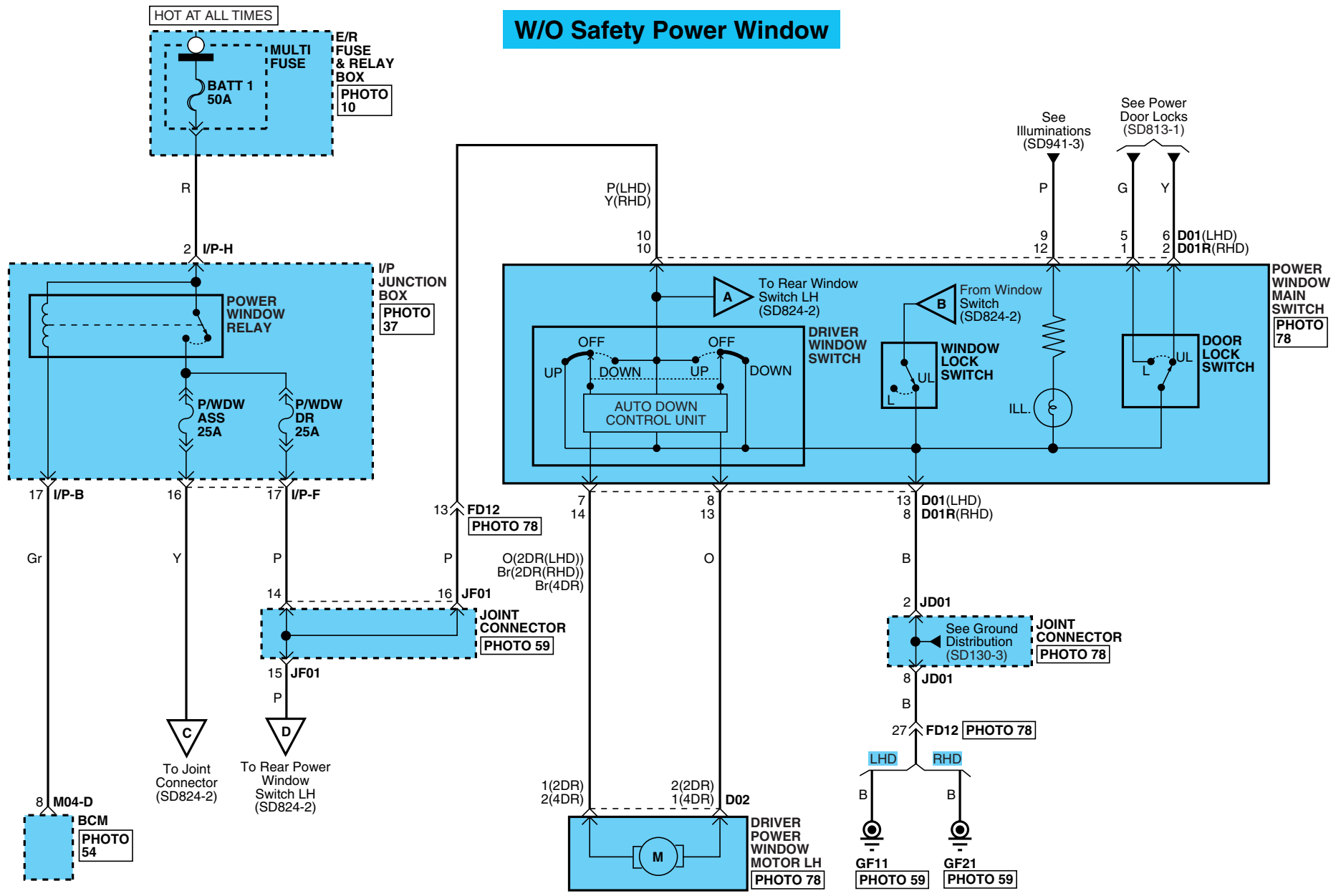

# POWER WINDOWS

## Power Windows (4)

SD824-4

### W/O Safety Power Window

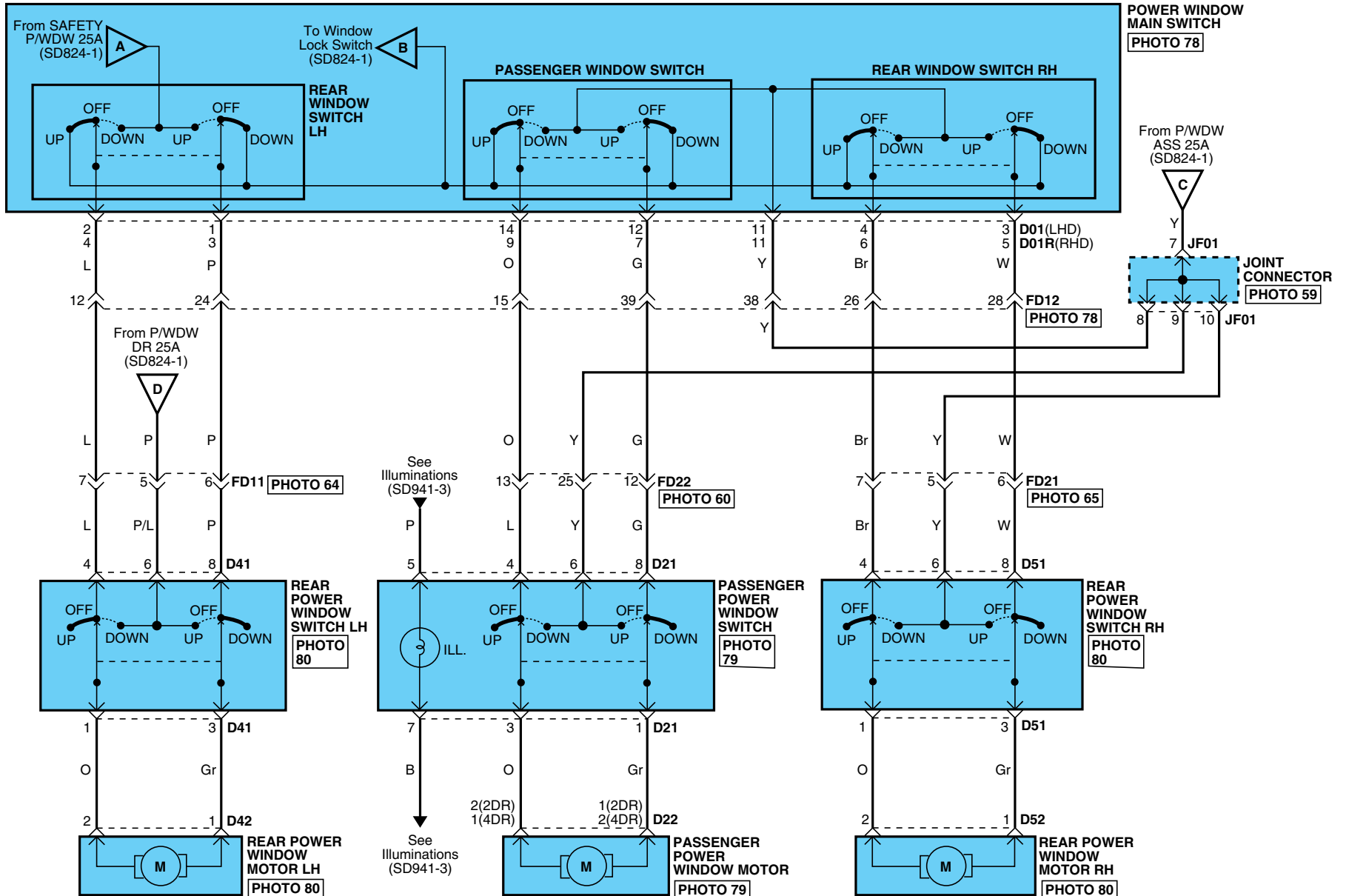

# POWER WINDOWS

## Power Windows (5)

SD824-5

**D01**

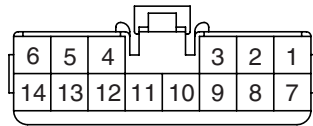

KET\_090II\_14F\_W

**D01R**

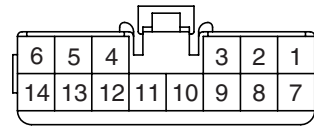

KET\_090II\_14F\_W

**D02**

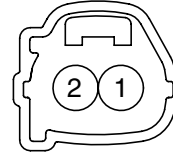

KET\_090IWP\_02F\_B\_L

**D03**

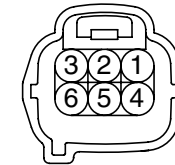

KET\_090IWP\_06F\_B

**D12**

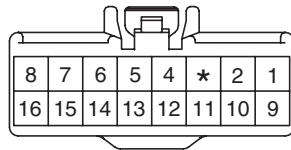

KET\_090III\_16F\_W

**D21**

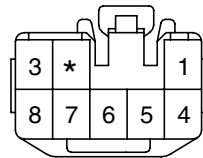

KET\_090II\_08F\_W

**D22**

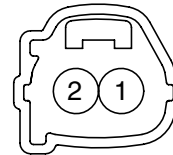

KET\_090IWP\_02F\_B\_L

**D41**

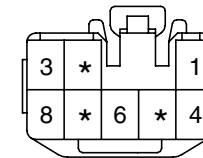

KET\_090II\_08F\_W

**D42**

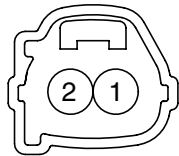

KET\_090IWP\_02F\_B\_L

**D51**

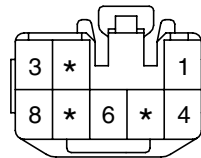

KET\_090II\_08F\_W

**D52**

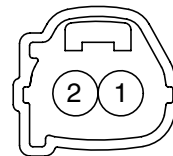

KET\_090IWP\_02F\_B\_L

**M04-D**

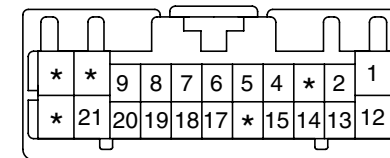

KET\_0407\_22F\_W

**POWER WINDOWS**

Power Windows (6)

SD824-6

MEMO

Electro Chromic Mirror (1)

SD851-1

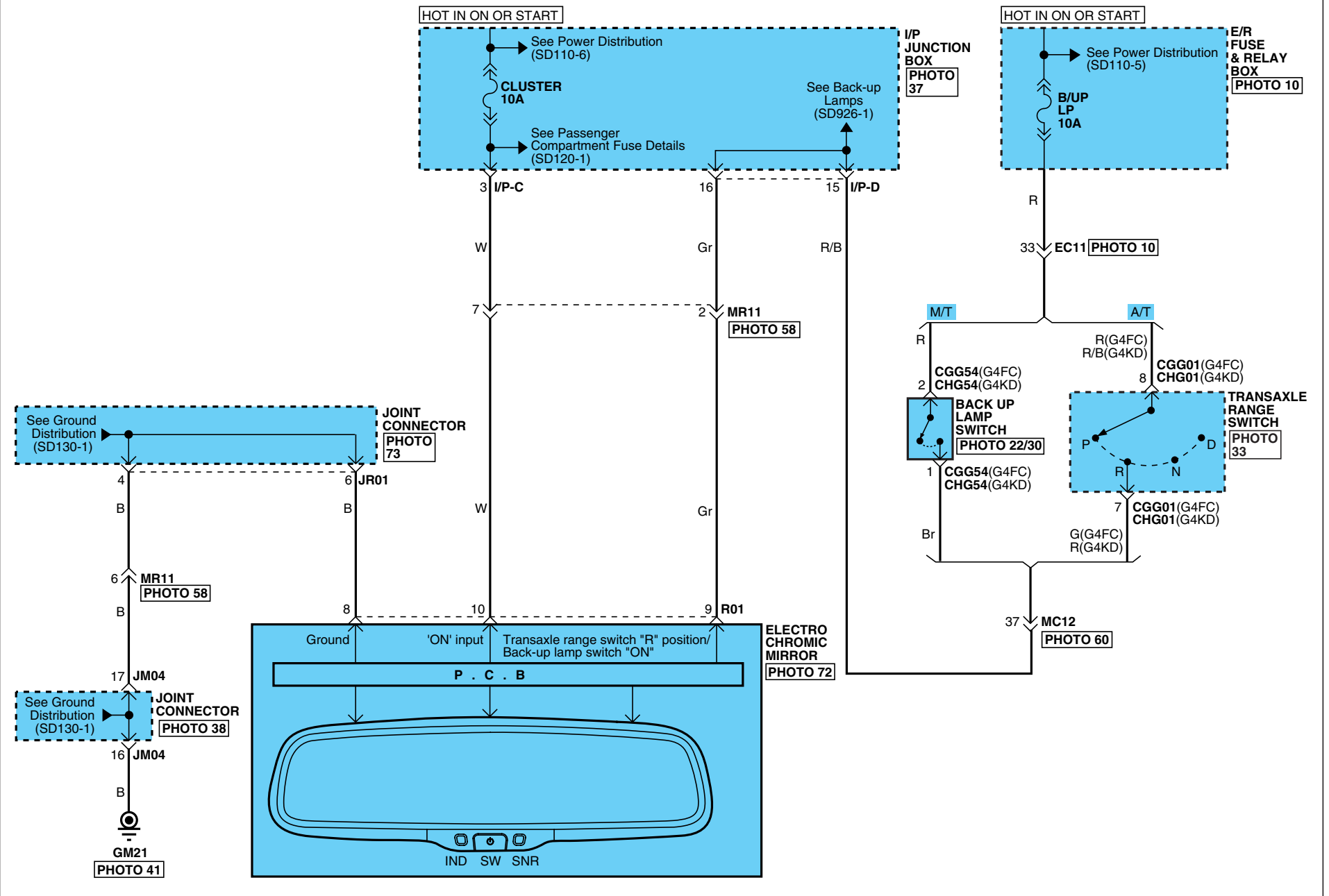

# ELECTRO CHROMIC MIRROR

## Electro Chromic Mirror (2)

SD851-2

**CGG01**



KET\_SSD\_10F\_B\_A

**CGG54**

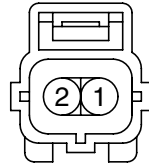

AMP\_EJWP\_02F\_B

**CHG01**



KET\_SSD\_10F\_B\_A

**CHG54**

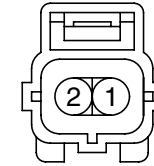

AMP\_EJWP\_02F\_B

**R01**

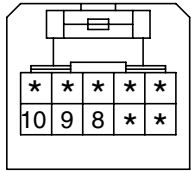

SUM\_025\_10F\_B

**BLANK**

**BLANK**

**BLANK**

Windshield Defogger System (1)

SD861-1

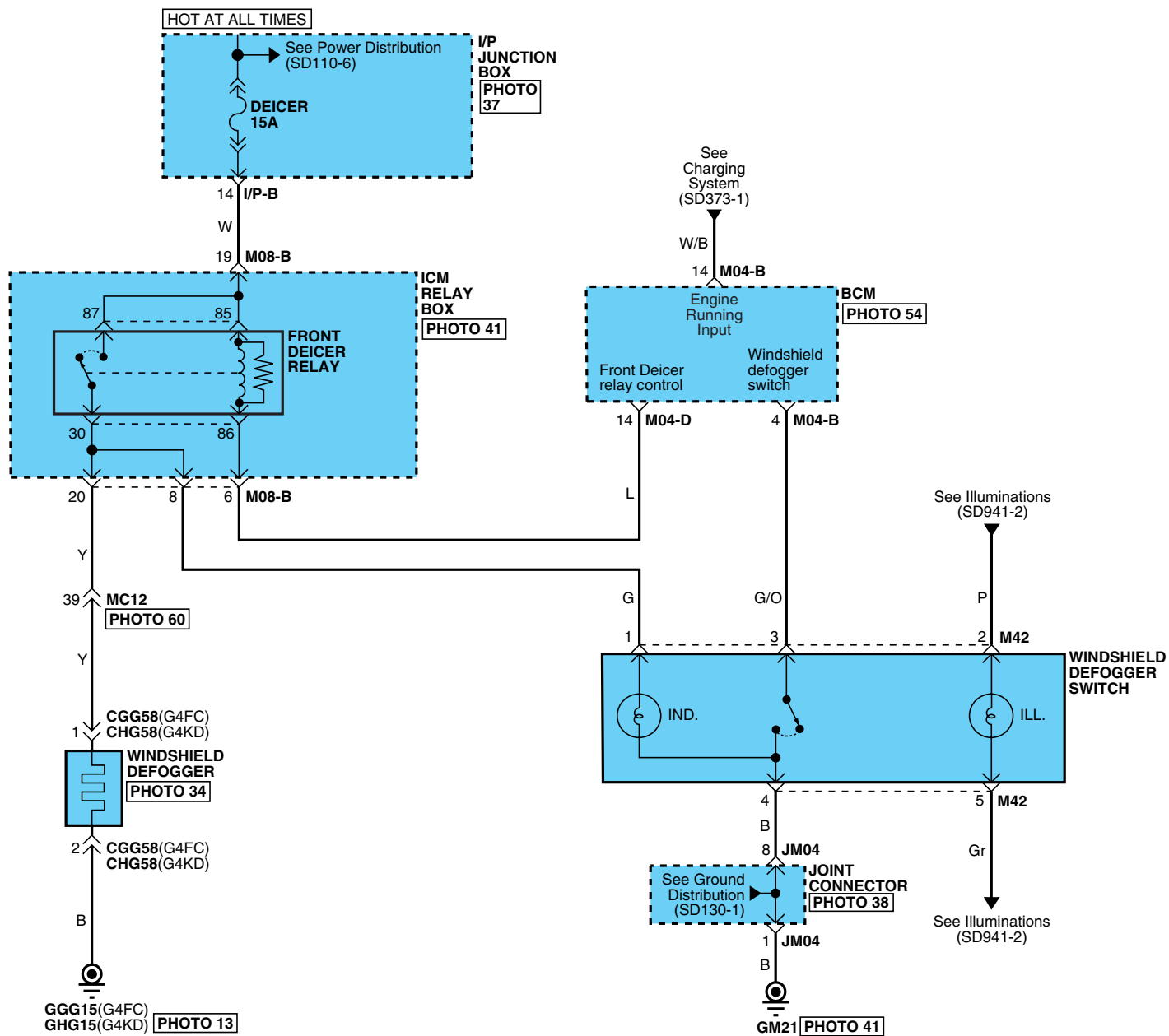



# WINDSHIELD DEFOGGER SYSTEM

## Windshield Defogger System (2)

SD861-2

**CGG58**

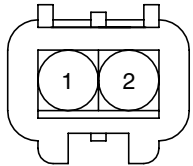

KUM\_NMWP\_02M\_B

**CHG58**

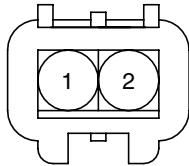

KUM\_NMWP\_02M\_B

**M04-B**

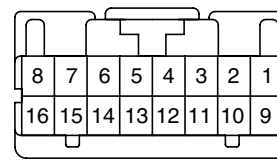

KET\_0407\_16F\_W

**M04-D**

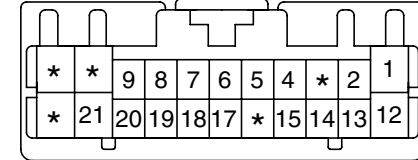

KET\_0407\_22F\_W

**M08-B**

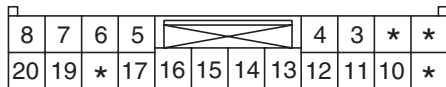

AMP\_0925\_20F\_W

**M42**

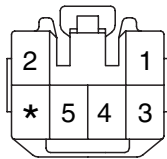

KET\_09011\_06F\_R

**BLANK**

**BLANK**

# POWER OUTSIDE MIRRORS

E835FFA4

## Power Outside Mirrors (1)

SD876-1

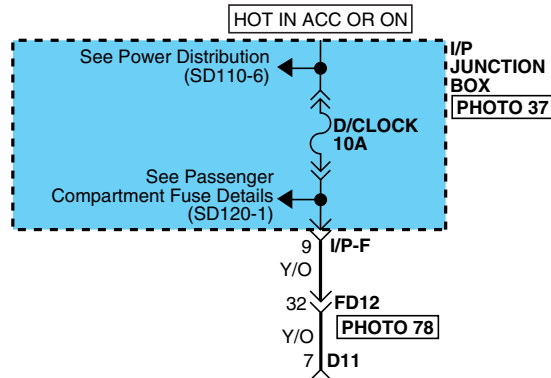

TABLE

MIRROR SELECT SWITCH	SELECTOR SWITCH POSITION	POSITION	PIN NO. (RHD)						
			7 (7)	10 (10)	4 (3)	6 (1)	12 (12)	1 (6)	3 (4)
LEFT	UP	UP	○	○	○	○	○		
	DOWN	DOWN	○	○	○	○	○		
	OFF	OFF	○	○	○	○	○	○	○
	LEFT	LEFT	○	○	○	○	○	○	○
RIGHT	UP	UP	○	○	○	○	○	○	○
	DOWN	DOWN	○	○	○	○	○	○	○
	OFF	OFF	○	○	○	○	○	○	○
	LEFT	LEFT	○	○	○	○	○	○	○
		RIGHT	○	○	○	○	○	○	○

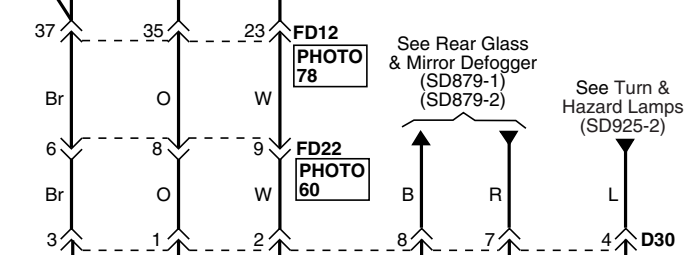
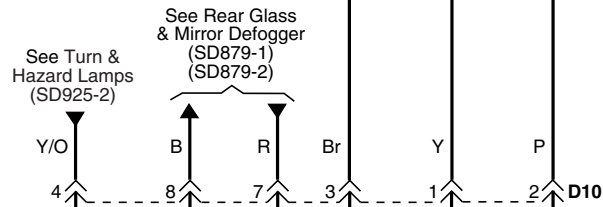
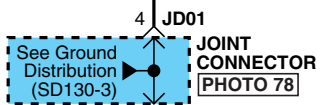
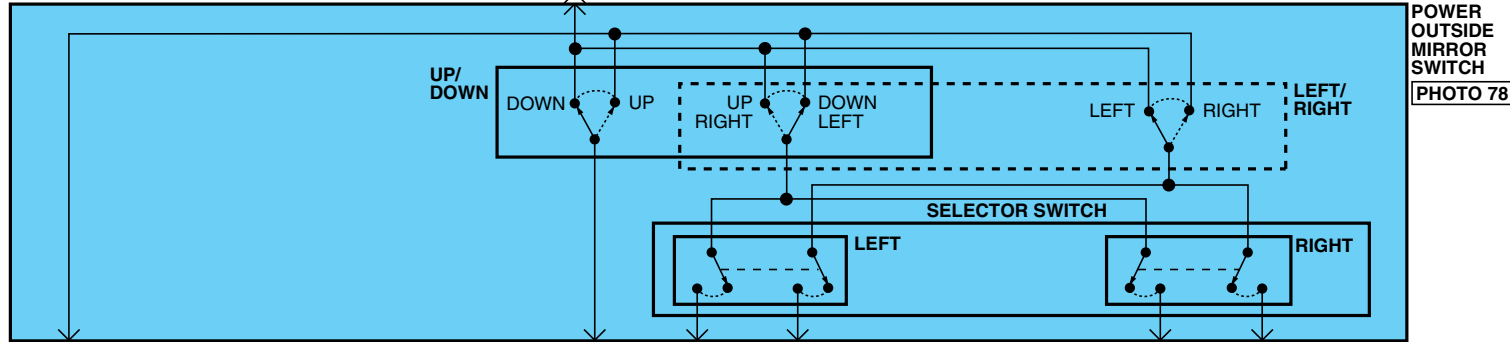

# POWER OUTSIDE MIRRORS

## Power Outside Mirrors (2)

SD876-2

D10

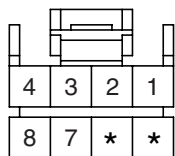

AMP\_040M1\_08F\_B

D11

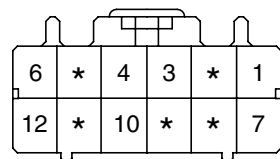

AMP\_0407\_12F\_W\_070

D30

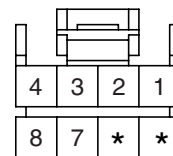

AMP\_040M1\_08F\_B

**BLANK**

Rear Glass & Mirror Defogger (1)

SD879-1

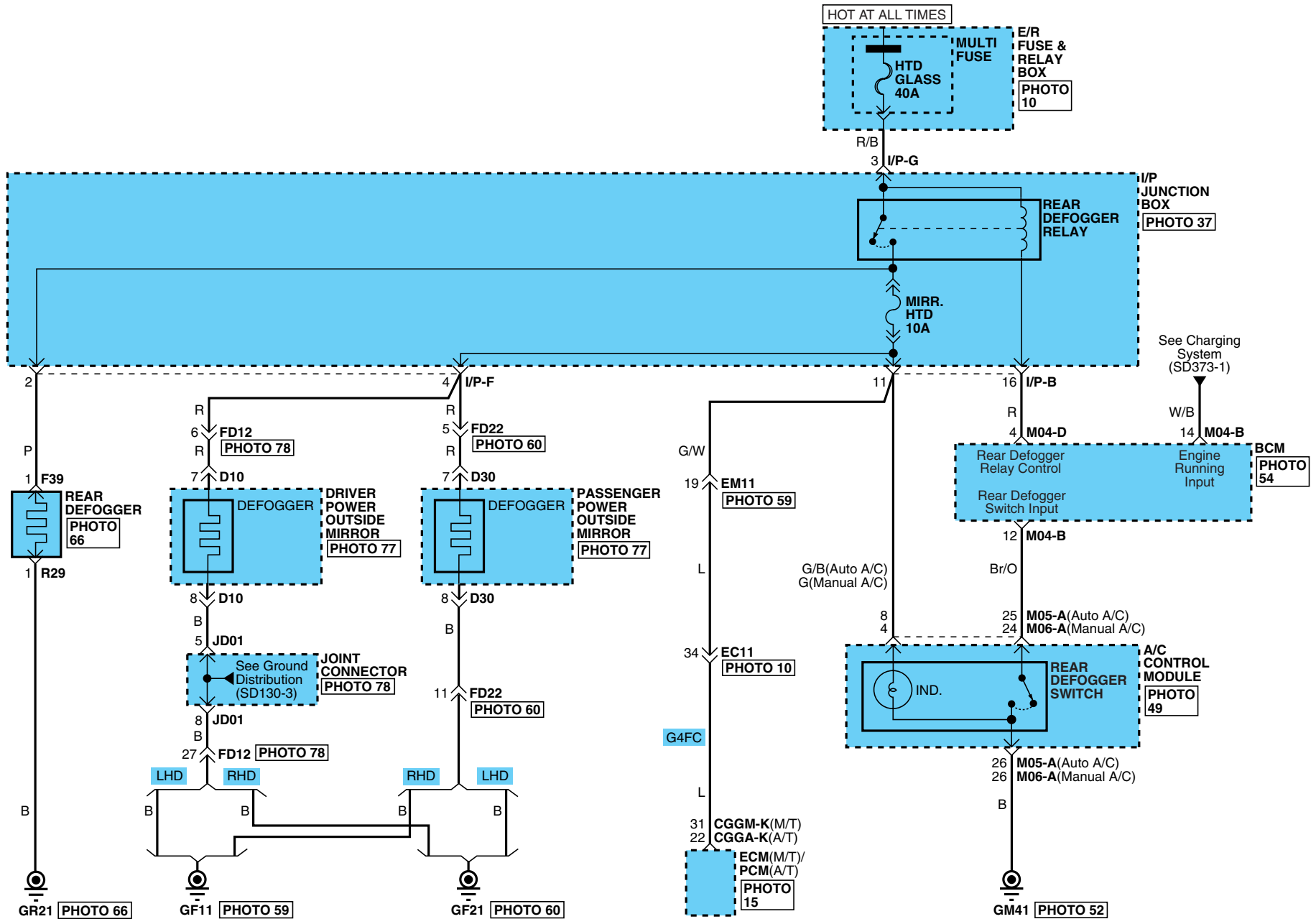

# REAR GLASS & MIRROR DEFOGGER

## Rear Glass & Mirror Defogger (2)

SD879-2

**CGGA-K**

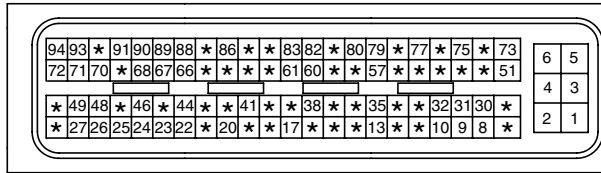

AMP\_ECU\_94F\_B

**CGGM-K**

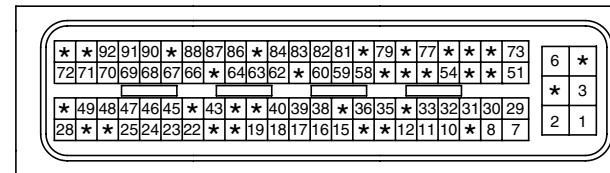

AMP\_ECU\_94F\_B

**D10**

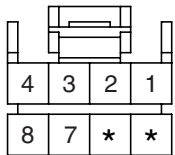

AMP\_040M1\_08F\_B

**D30**

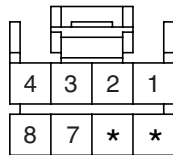

AMP\_040M1\_08F\_B

**F39**



AMP\_PLM1\_01F\_B

**M04-B**

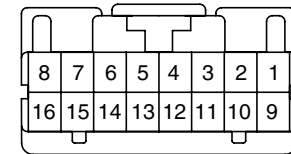

KET\_0407\_16F\_W

**M04-D**

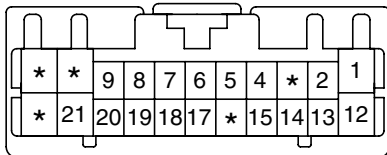

KET\_0407\_22F\_W

**M05-A**

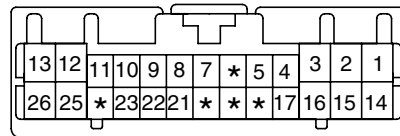

KET\_0407\_26F\_W

**M06-A**

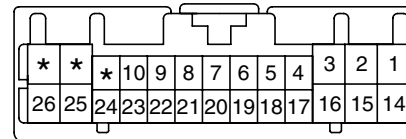

KET\_0407\_26F\_W

**R29**



AMP\_PLM1\_01F\_B

Seat Warmer (1)

SD889-1

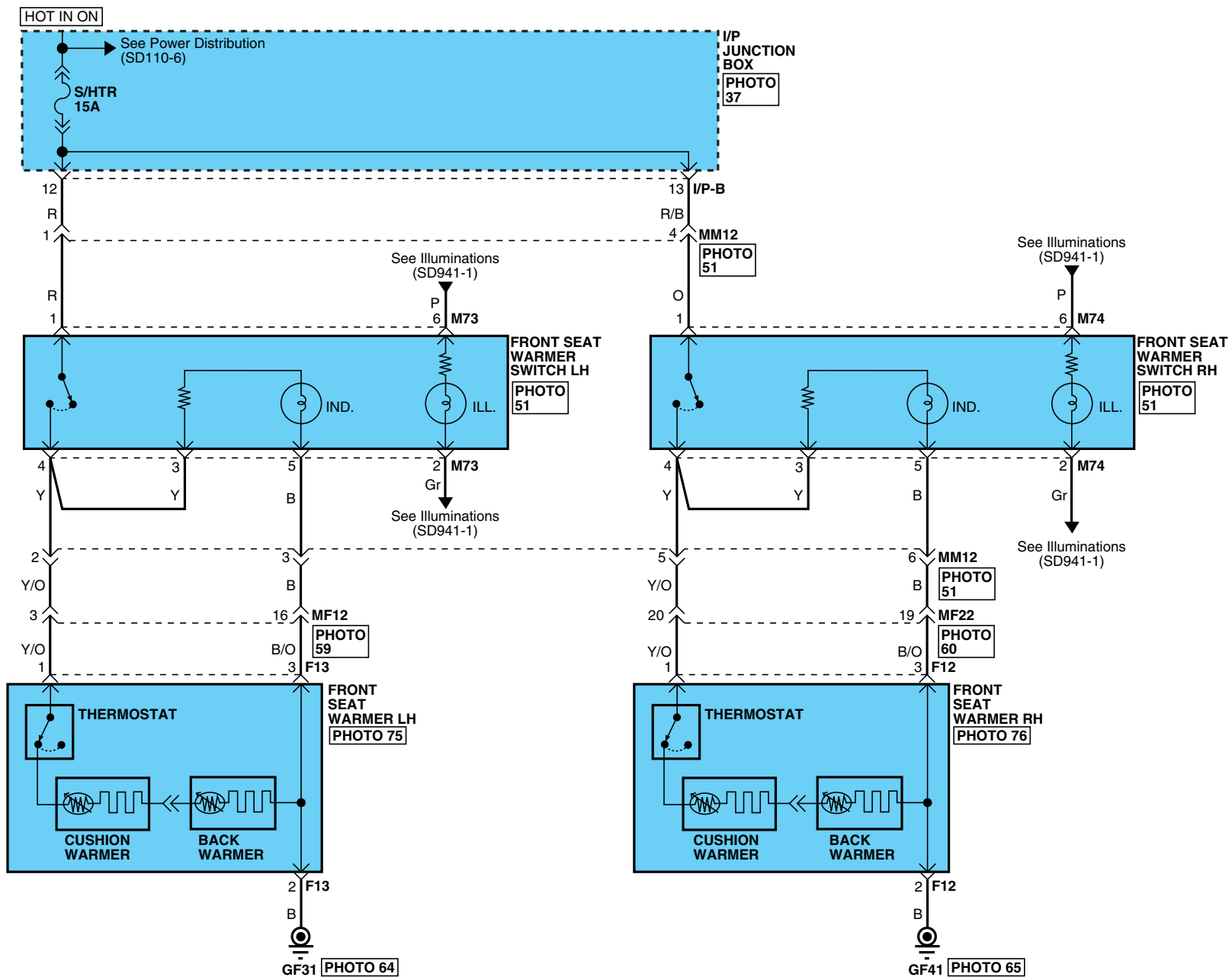

# SEAT WARMER

## Seat Warmer (2)

SD889-2

F12

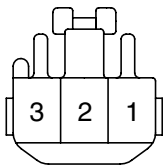

KET\_090II\_03F\_W

F13

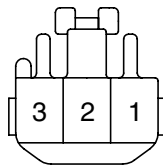

KET\_090II\_03F\_W

M73

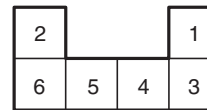

MG651044(KET)\_F

M74

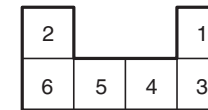

1743184(AMP)\_F

Head Lamps (1)

SD921-1

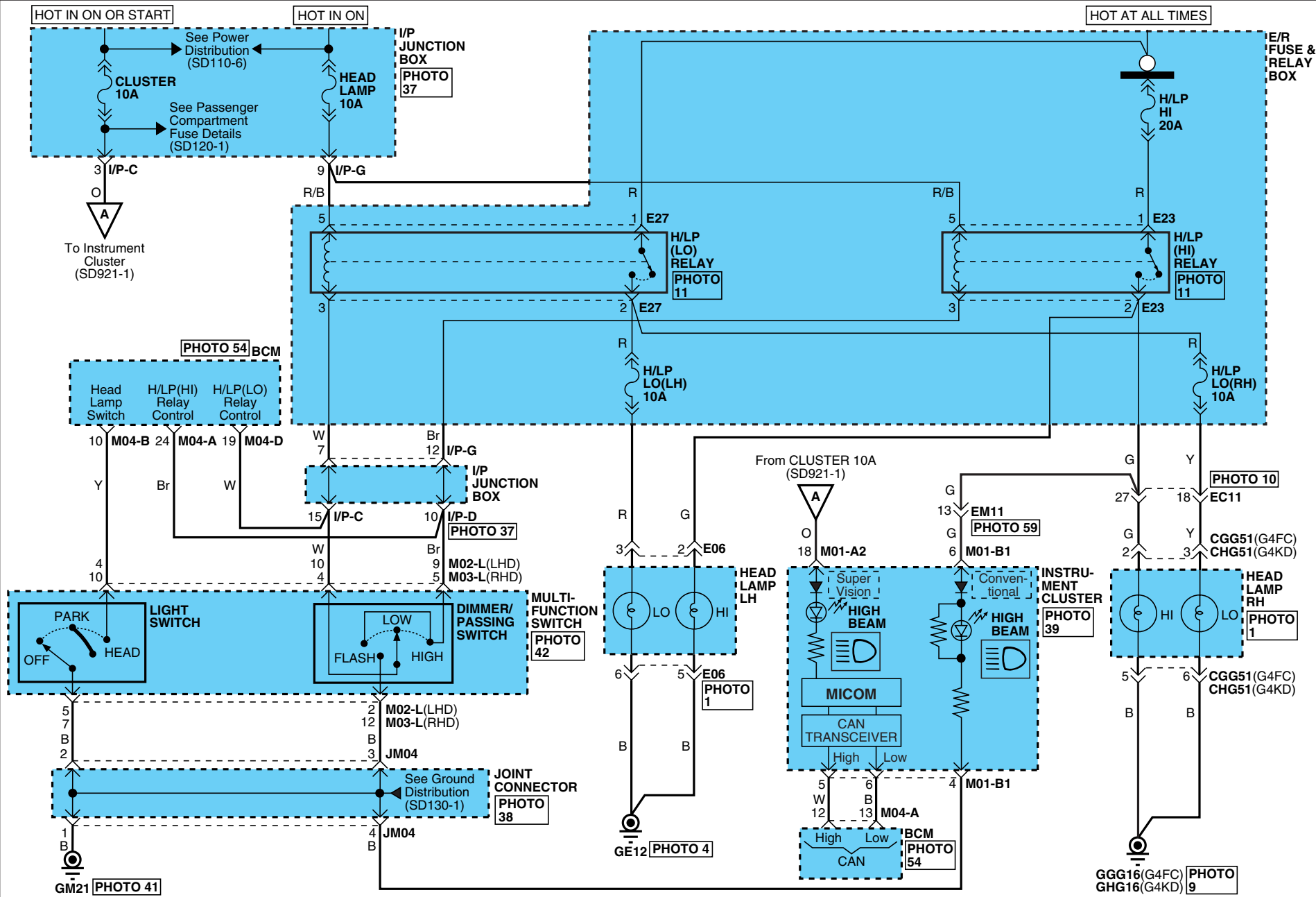



# HEAD LAMPS

## Head Lamps (2)

SD921-2

**CGG51**

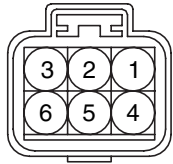

KUM\_NMWP\_06F\_B

**CHG51**

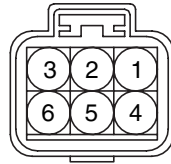

KUM\_NMWP\_06F\_B

**E06**

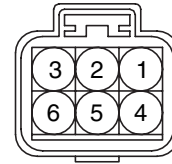

KUM\_NMWP\_06F\_B

**E23**

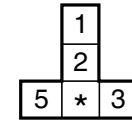

CR05F011

**E27**

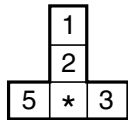

CR05F011

**M01-A2**

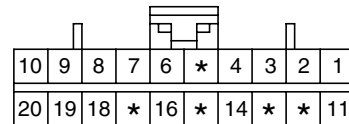

AMP\_040M2\_20F\_B

**M01-B1**

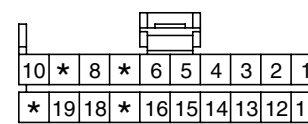

AMP\_040M1\_20F\_B

**M02-L**

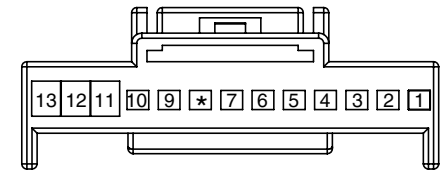

KET\_0409\_13F\_W

**M03-L**

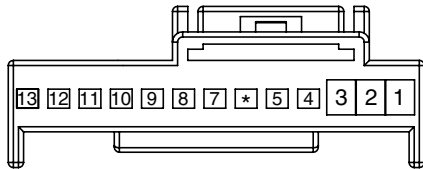

KET\_0409\_13F\_B

**M04-A**

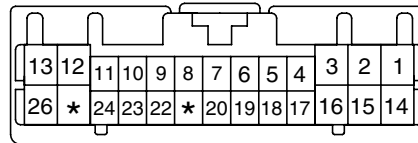

KET\_0407\_26F\_W

**M04-B**

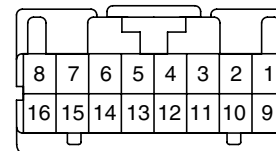

KET\_0407\_16F\_W

**M04-D**

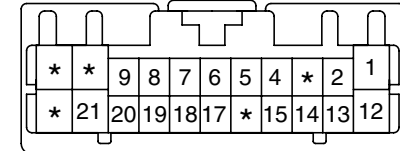

KET\_0407\_22F\_W

Head Lamp Leveling Device (1)

SD922-1

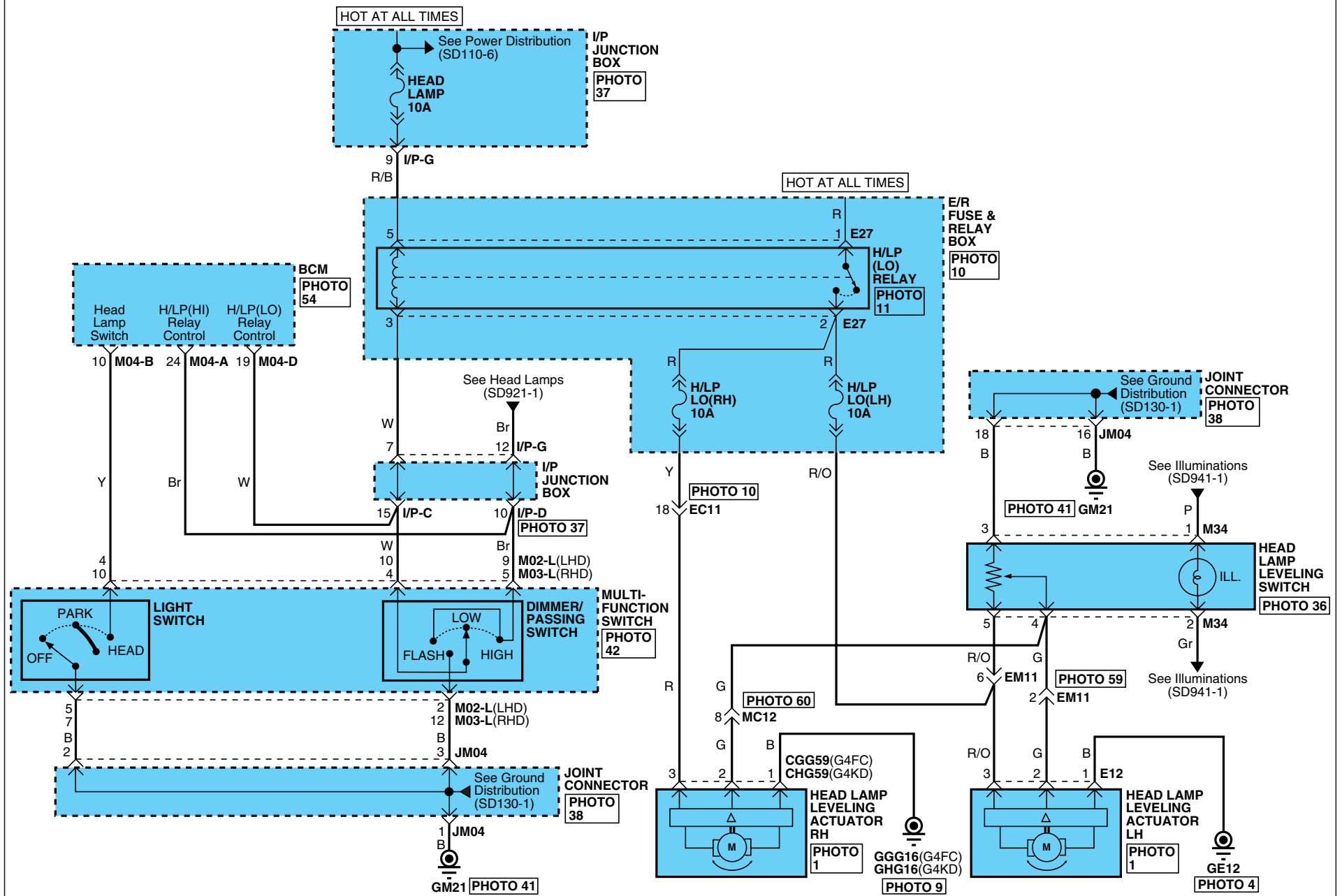

# HEAD LAMP LEVELING DEVICE

## Head Lamp Leveling Device (2)

SD922-2

**CGG59**

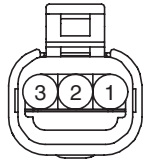

AMP\_025WP\_03F\_B

**CHG59**

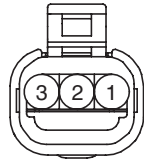

AMP\_025WP\_03F\_B

**E12**

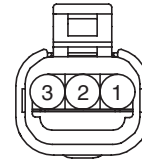

AMP\_025WP\_03F\_B

**E27**

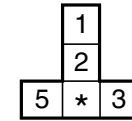

CR05F011

**M02-L**

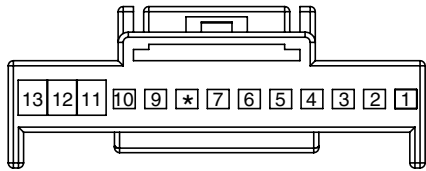

KET\_0409\_13F\_W

**M03-L**

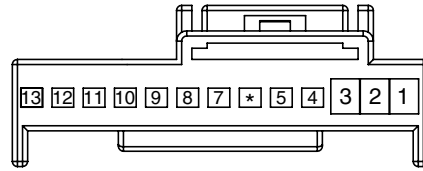

KET\_0409\_13F\_B

**M04-A**

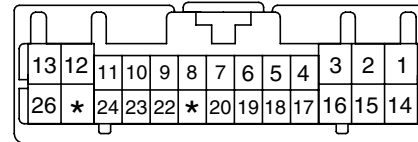

KET\_0407\_26F\_W

**M04-B**

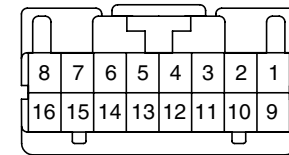

KET\_0407\_16F\_W

**M04-D**

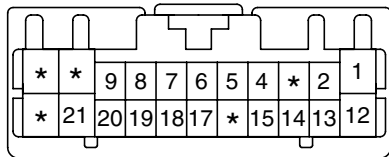

KET\_0407\_22F\_W

**M34**

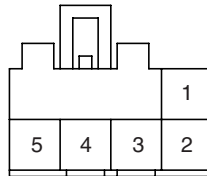

AMP\_025WP\_03F\_B

**BLANK**

**BLANK**

**FRONT FOG & REAR FOG LAMPS** E1CF4C6D

**Front Fog & Rear Fog Lamps (1)**

**SD924-1**

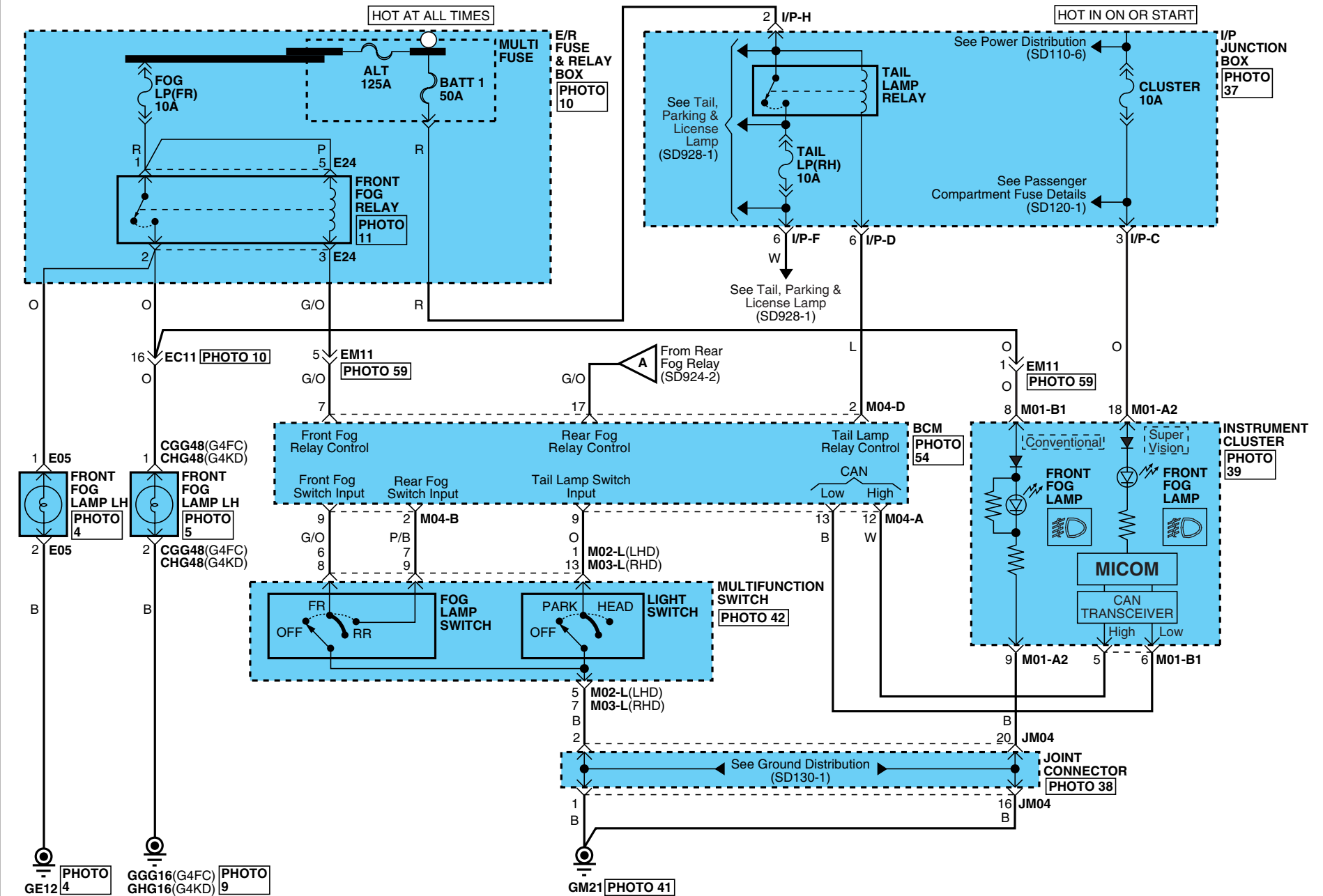

# FRONT FOG & REAR FOG LAMPS

## Front Fog & Rear Fog Lamps (2)

SD924-2

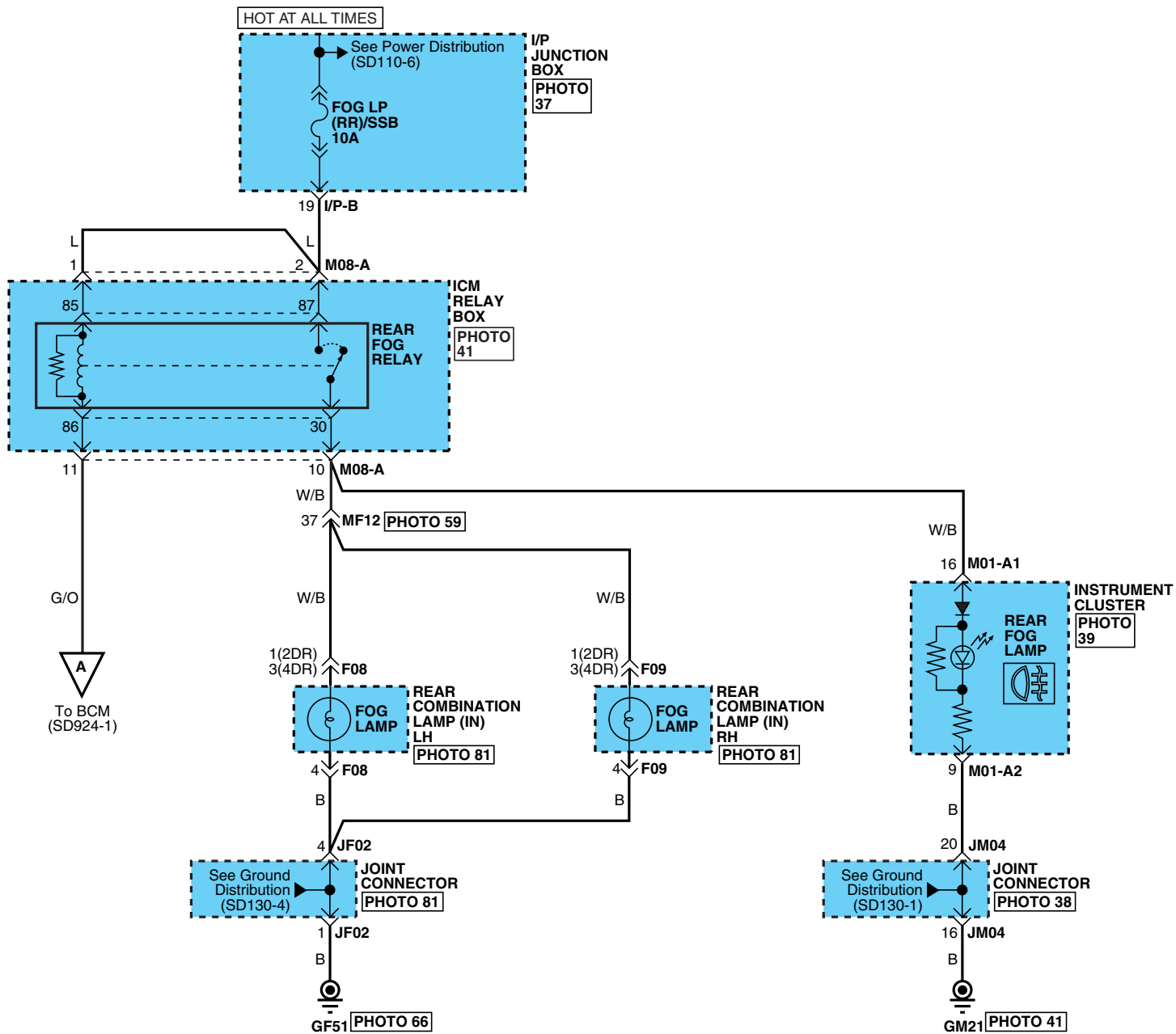

# FRONT FOG & REAR FOG LAMPS

## Front Fog & Rear Fog Lamps (3)

SD924-3

CGG48



KET\_110WP\_02F\_B\_FOG

CHG48



KET\_110WP\_02F\_B\_FOG

E05

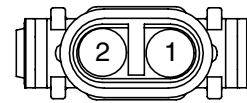

KET\_110WP\_02F\_B\_FOG

E24

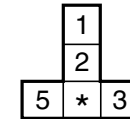

CR05F011

F08

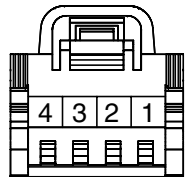

KET\_62C\_04F\_W

F09

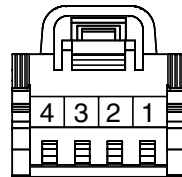

KET\_62C\_04F\_W

M01-A1

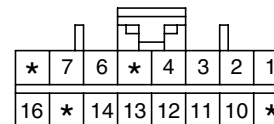

AMP\_040M2\_16F\_W

M01-A2

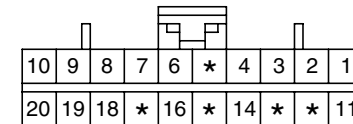

AMP\_040M2\_20F\_B

M01-B1

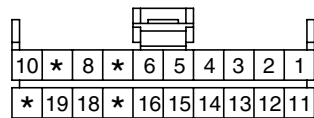

AMP\_040M1\_20F\_B

M02-L

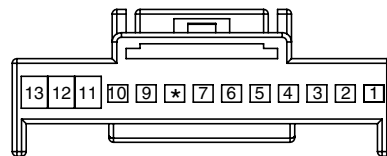

KET\_0409\_13F\_W

M03-L

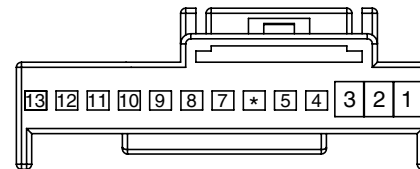

KET\_0409\_13F\_B

M04-A

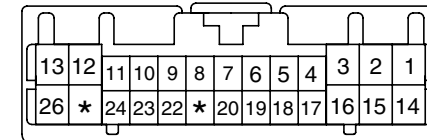

KET\_0407\_26F\_W

M04-B

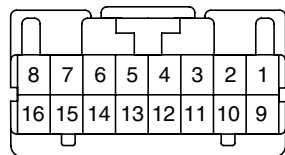

KET\_0407\_16F\_W

M04-D

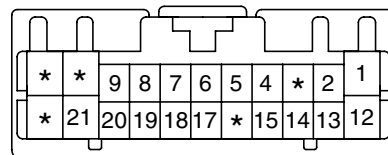

KET\_0407\_22F\_W

M08-A

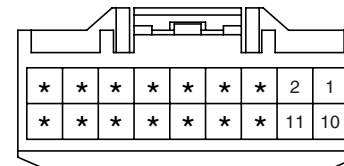

AMP\_090III\_18F\_W

BLANK

**FRONT FOG & REAR FOG LAMPS**

**Front Fog & Rear Fog Lamps (4)**

**SD924-4**

**MEMO**

Turn & Hazard Lamps (1)

SD925-1

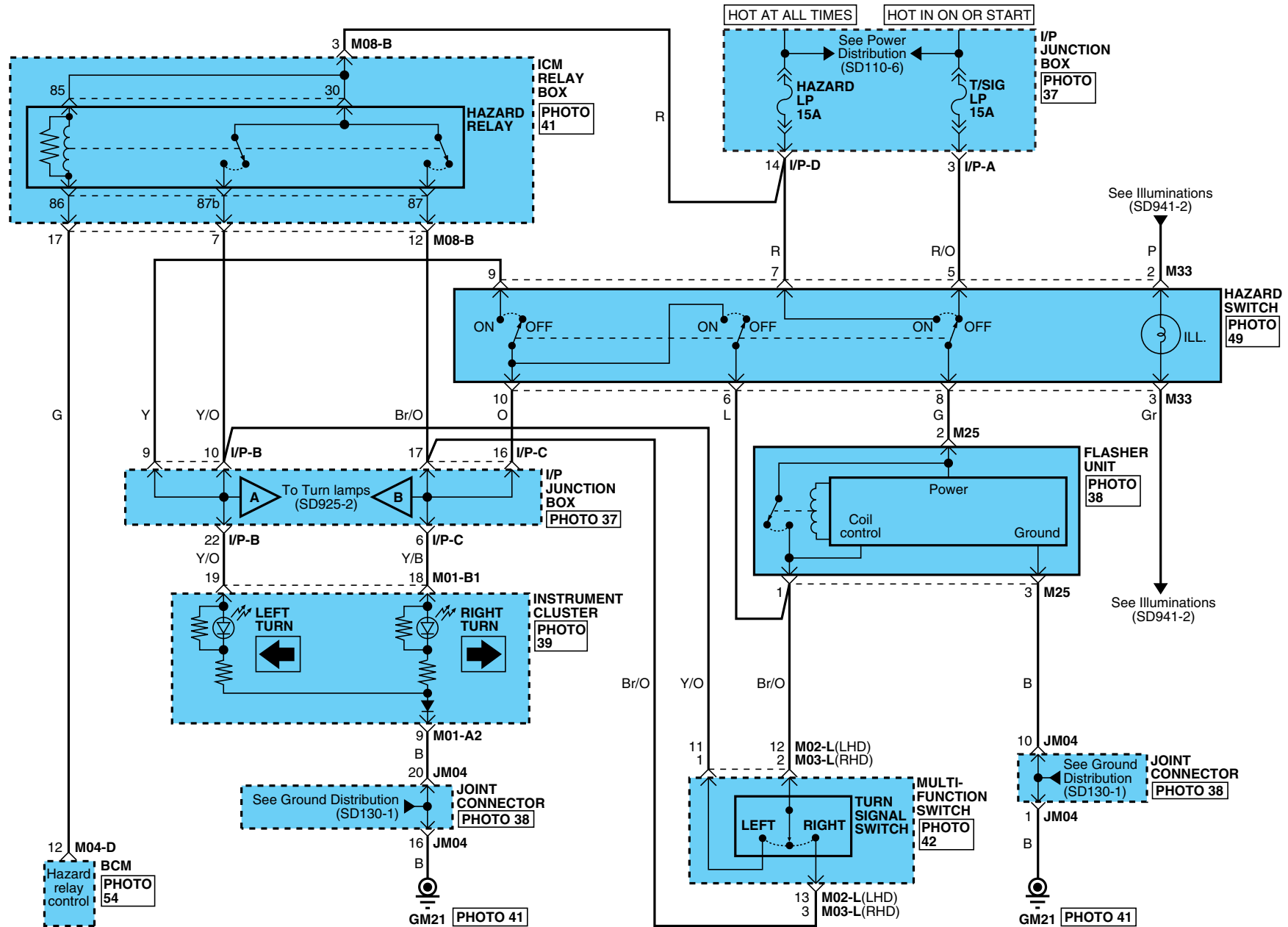



# TURN & HAZARD LAMPS

## Turn & Hazard Lamps (2)

SD925-2

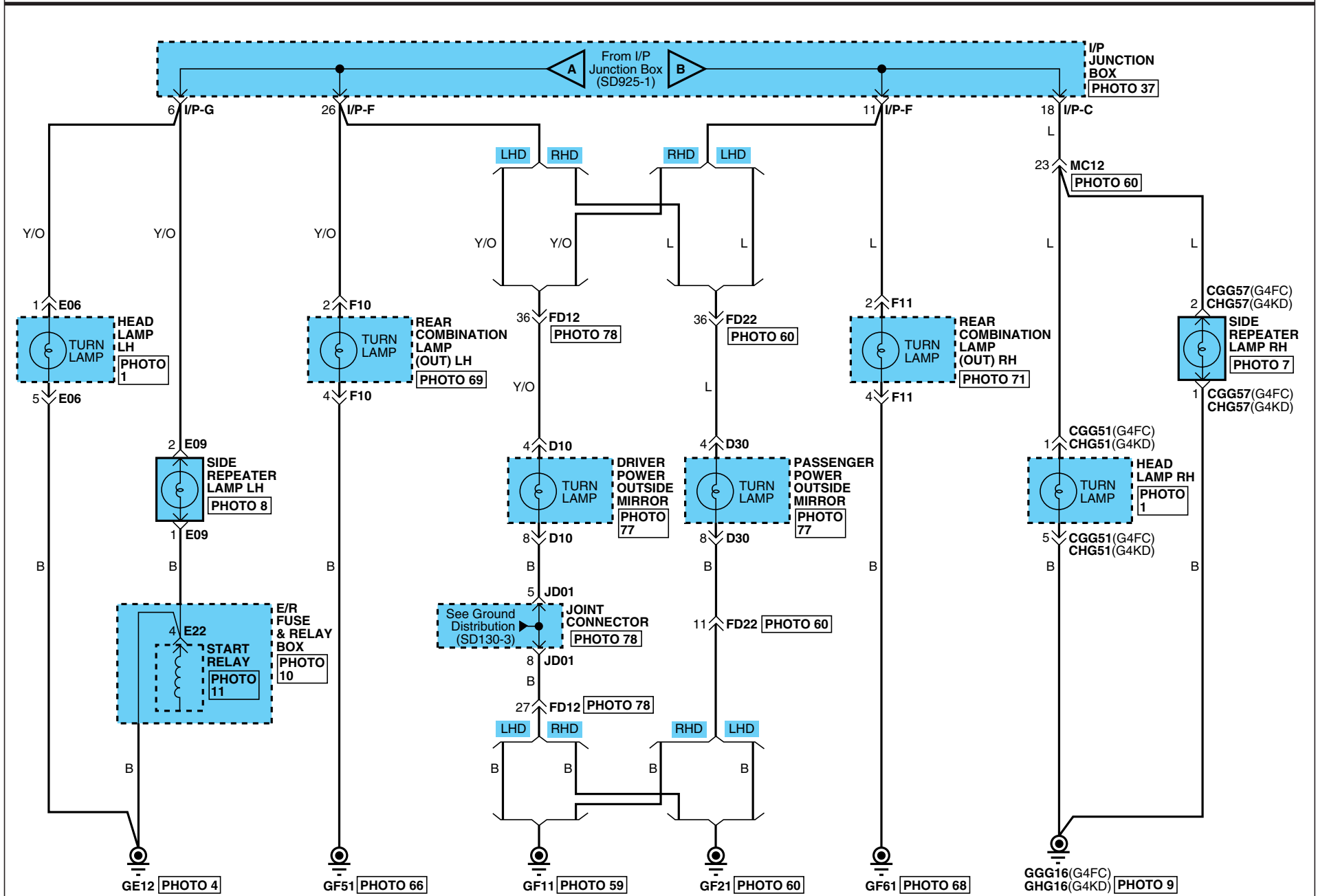

# TURN & HAZARD LAMPS

## Turn & Hazard Lamps (3)

SD925-3

**CGG51**

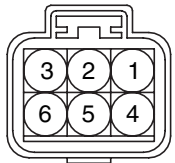

KUM\_NMWP\_06F\_B

**CGG57**

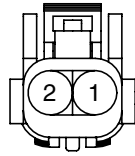

KUM\_62Z\_02F\_GR

**CHG51**

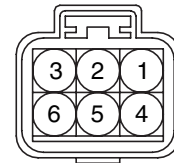

KUM\_NMWP\_06F\_B

**CHG57**

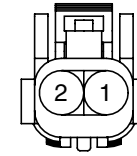

KUM\_62Z\_02F\_GR

**D10**

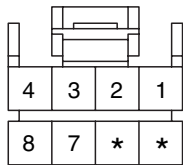

AMP\_040M1\_08F\_B

**D30**

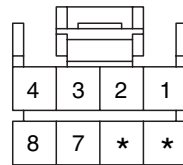

AMP\_040M1\_08F\_B

**E06**

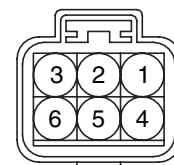

KUM\_NMWP\_06F\_B

**E09**

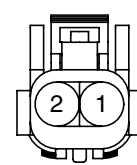

KUM\_62Z\_02F\_GR

**E22**

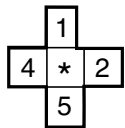

CR05F012

**F10**

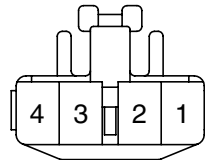

KET\_090II\_04F\_W

**F11**

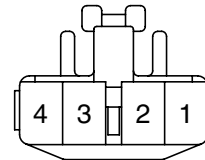

KET\_090II\_04F\_W

**M01-A2**

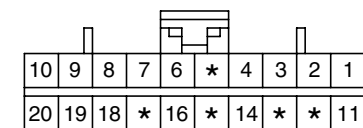

AMP\_040M2\_20F\_B

**M01-B1**

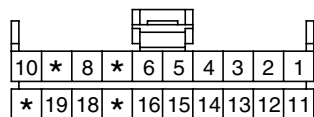

AMP\_040M1\_20F\_B

**M02-L**

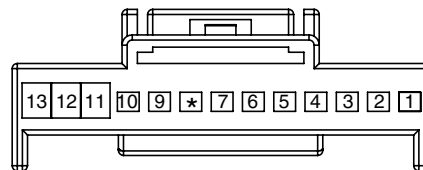

KET\_0409\_13F\_W

**M03-L**

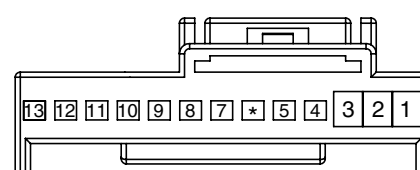

KET\_0409\_13F\_B

**M04-D**

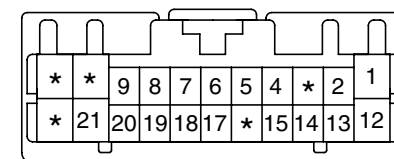

KET\_0407\_22F\_W

**M08-B**

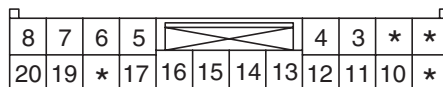

AMP\_0925\_20F\_W

**M25**

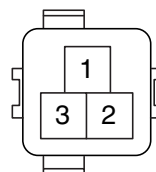

AMP\_187\_03F\_B\_RLY

**M33**

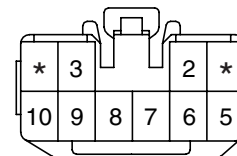

KET\_090II\_10F\_W

**BLANK**

**TURN & HAZARD LAMPS**

Turn & Hazard Lamps (4)

SD925-4

MEMO

Back-Up Lamps (1)

SD926-1

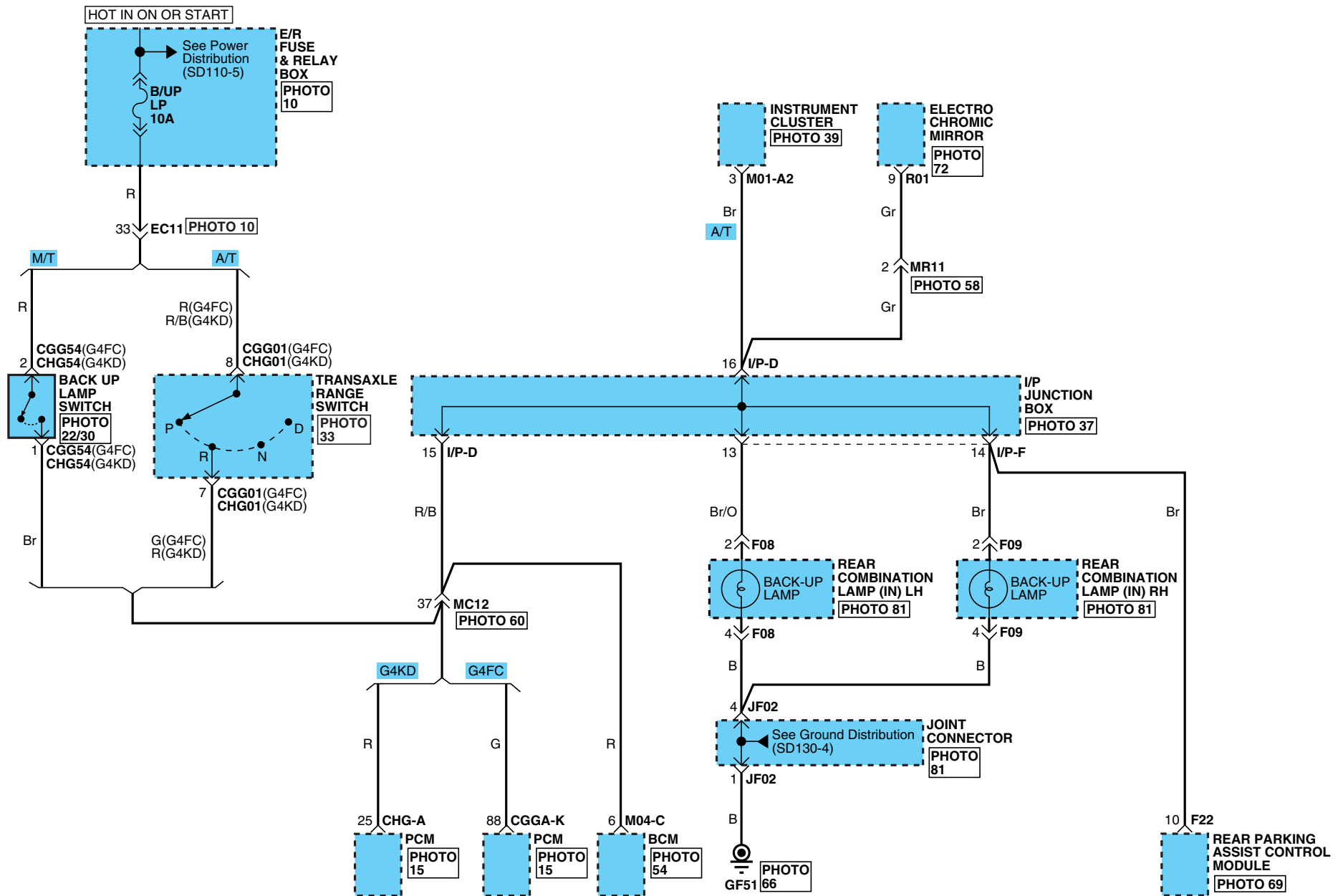

# BACK-UP LAMPS

## Back-Up Lamps (2)

SD926-2

**CGGA-K**

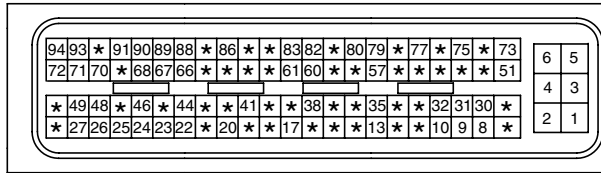

AMP\_ECU\_94F\_B

**CHG-A**

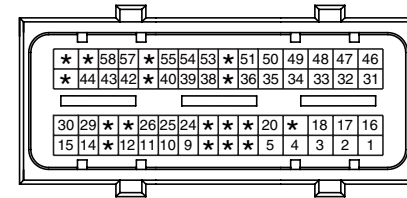

AMP\_ECU\_60F\_B\_A

**CGG01**



KET\_SSD\_10F\_B\_A

**CGG54**

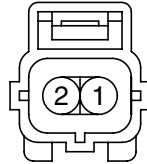

AMP\_EJWP\_02F\_B

**CHG01**



KET\_SSD\_10F\_B\_A

**CHG54**

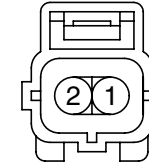

AMP\_EJWP\_02F\_B

**F08**

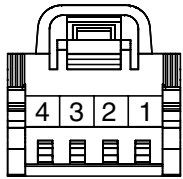

KET\_62C\_04F\_W

**F09**

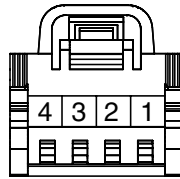

KET\_62C\_04F\_W

**F22**

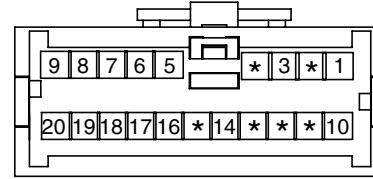

KUM\_040III\_20F\_W

**M01-A2**

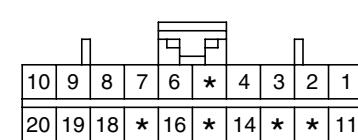

AMP\_040M2\_20F\_B

**M04-C**

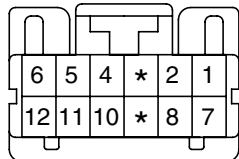

KET\_0407\_12F\_W

**R01**

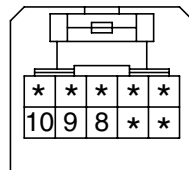

SUM\_025\_10F\_B

**BLANK**

**BLANK**

Stop Lamps (1)

G4FC - GSL 1.6L

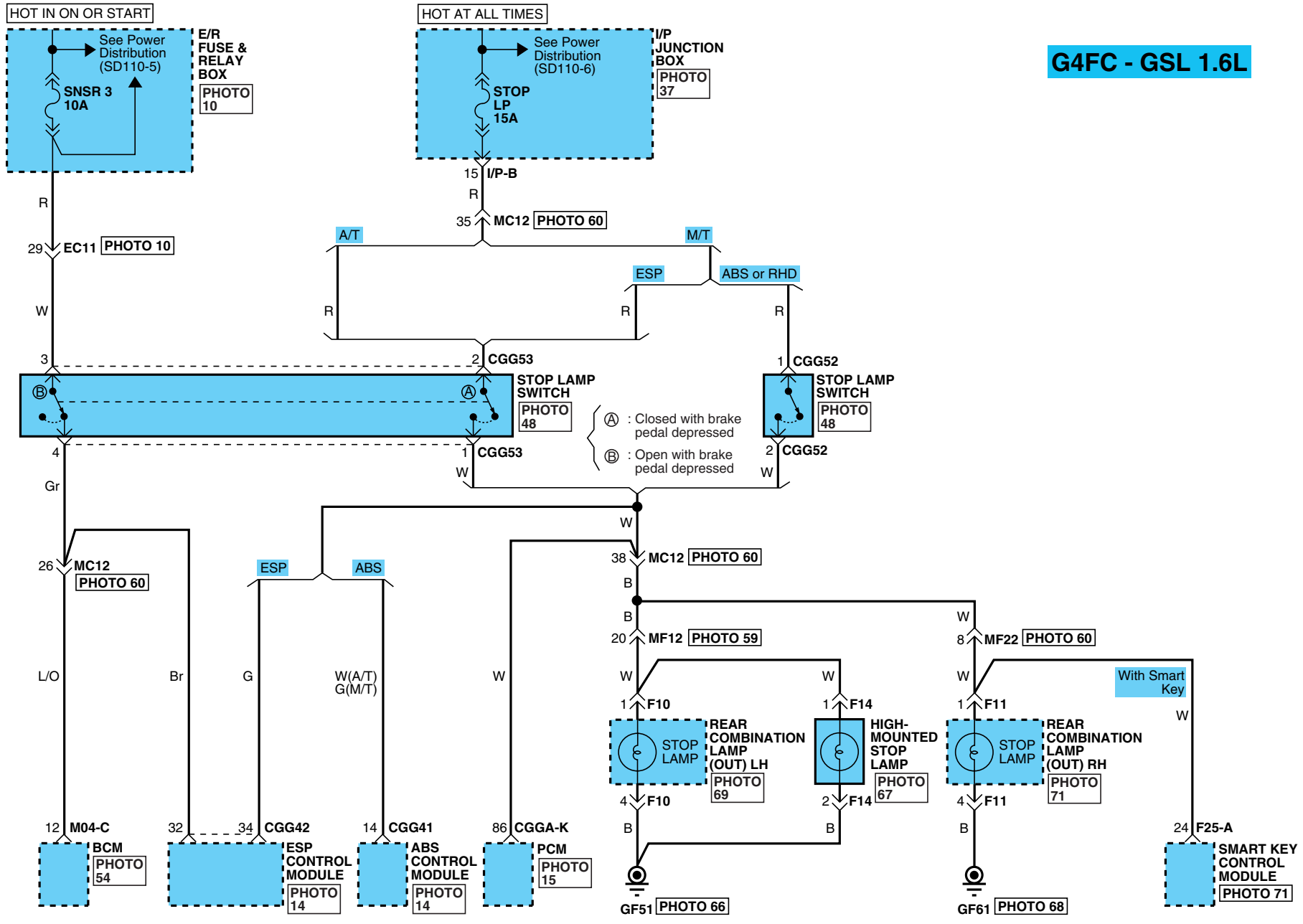

# STOP LAMPS

## Stop Lamps (2)

SD927-2

**G4KD - GSL 2.0L**

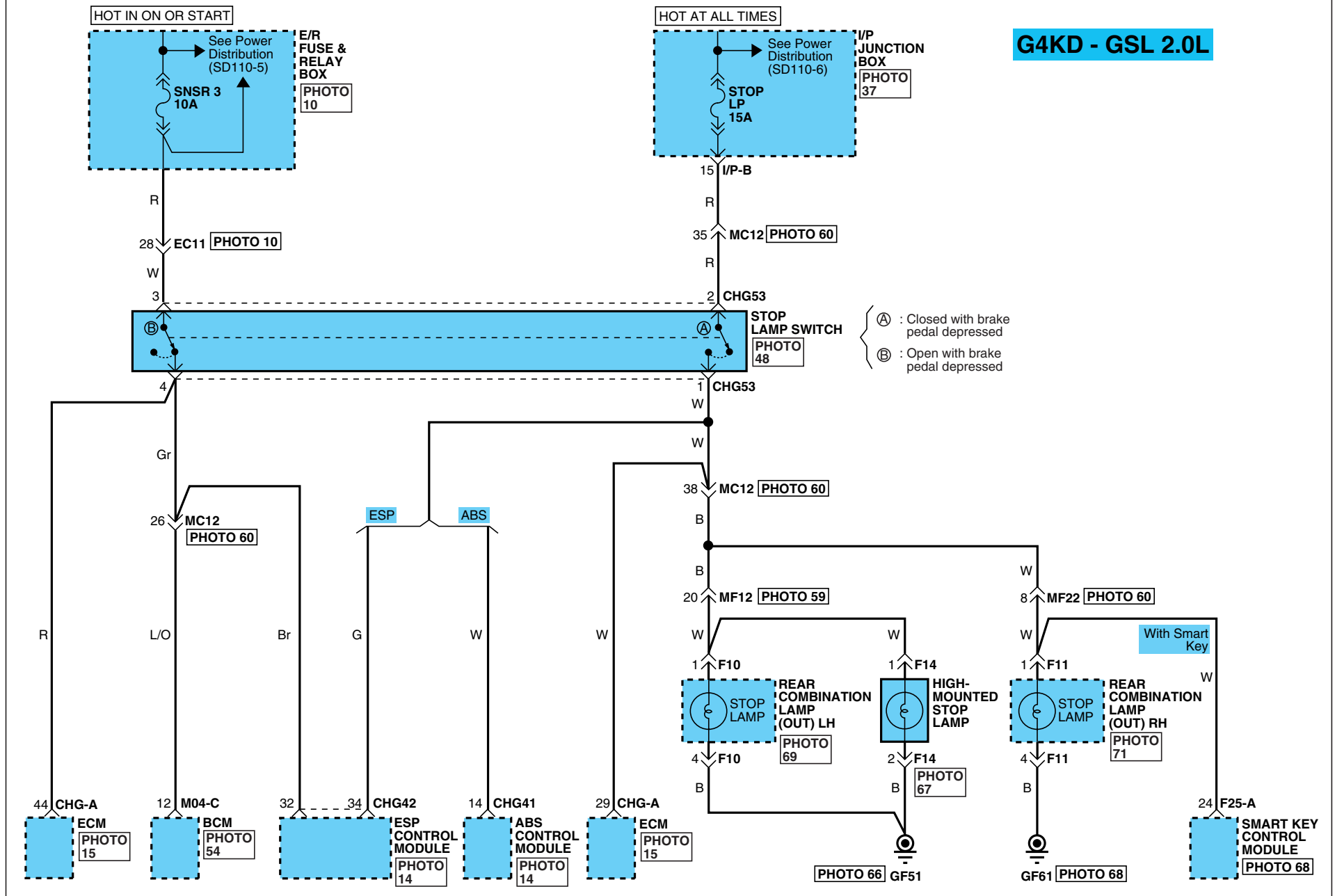

# STOP LAMPS

## Stop Lamps (3)

SD927-3

**CGGA-K**

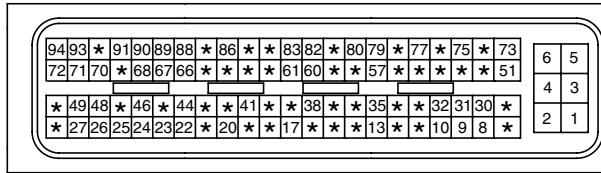

AMP\_ECU\_94F\_B

**CHG-A**

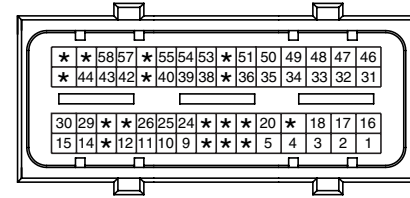

AMP\_ECU\_60F\_B\_A

**CGG41**

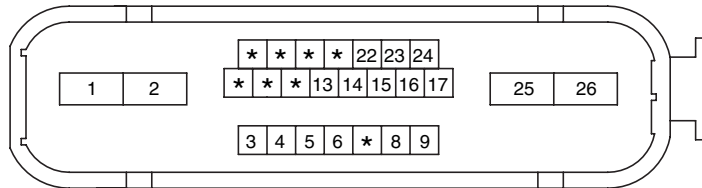

AMP\_ABS\_26F\_B

**CGG42**

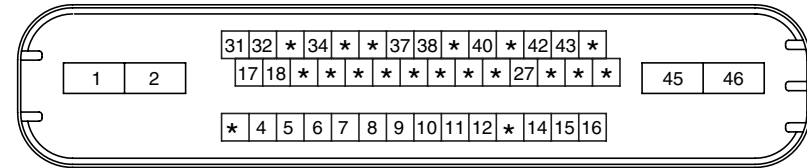

AMP\_ESP\_46F\_B

**CGG52**

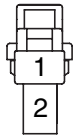

KET\_250DL\_02F\_B

**CGG53**

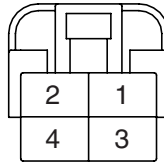

KET\_250DL\_04F\_W

**CHG41**

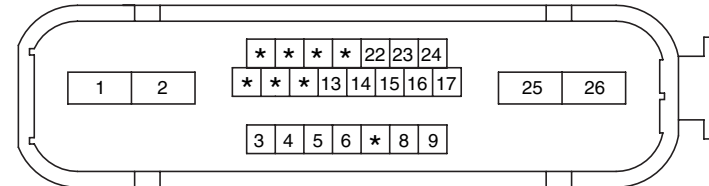

AMP\_ABS\_26F\_B

**CHG42**

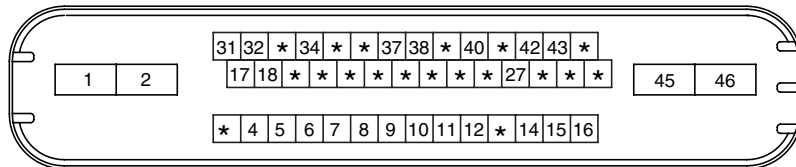

AMP\_ESP\_46F\_B

**CHG53**

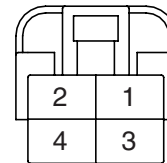

KET\_250DL\_04F\_W

**F10**

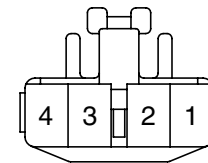

KET\_090II\_04F\_W

**F11**

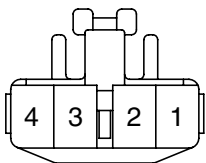

KET\_090II\_04F\_W

**F14**

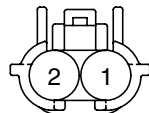

KET\_SWP\_02F\_B

**F25-A**

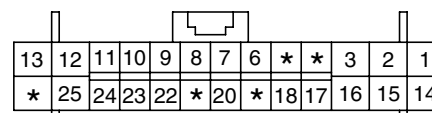

AMP\_0407\_26F\_W\_HD

**M04-C**

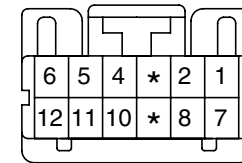

KET\_0407\_12F\_W



**STOP LAMPS**

Stop Lamps (4)

SD927-4

MEMO

Tail, Parking & License Lamps (1)

SD928-1

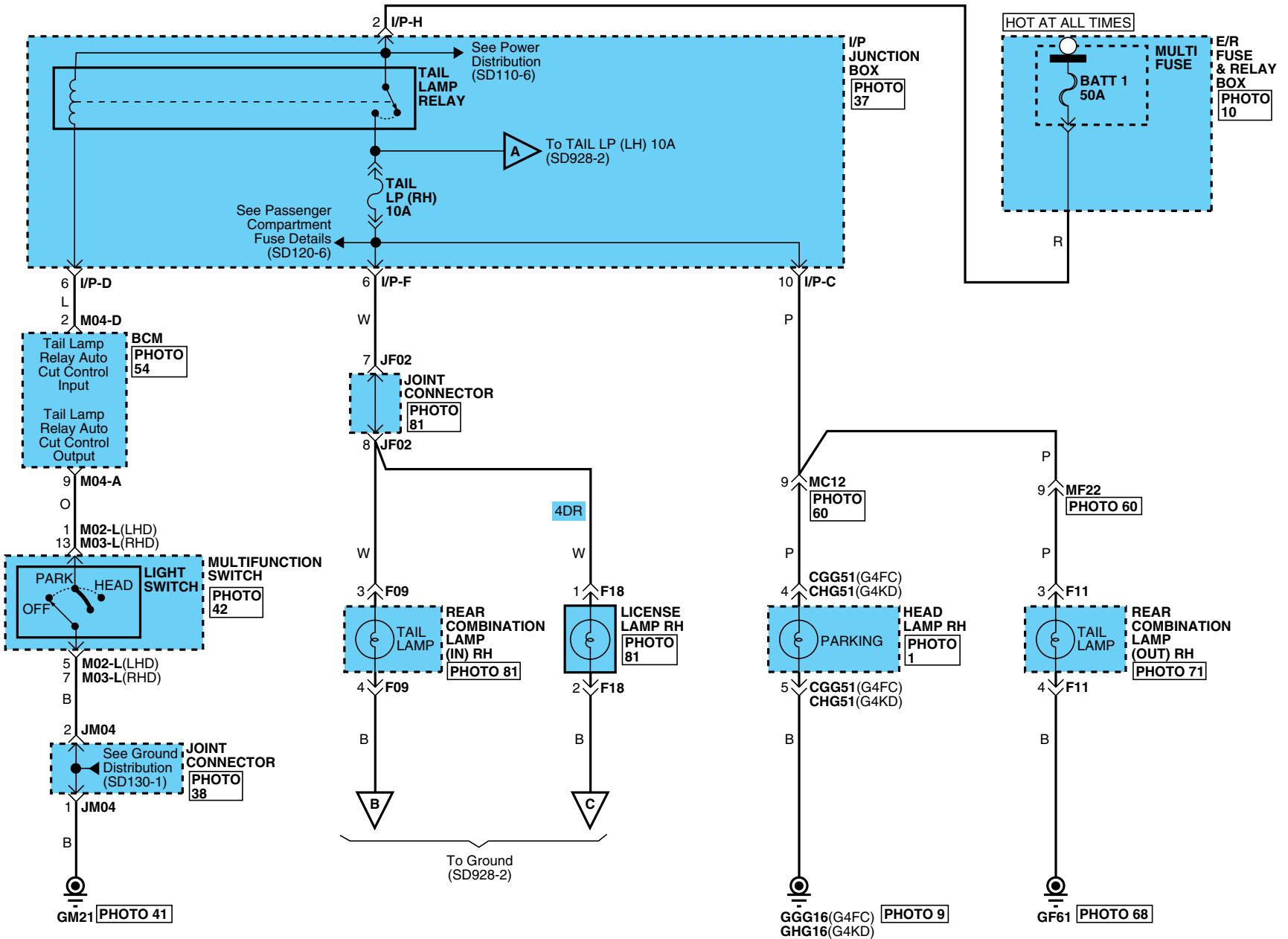



# TAIL, PARKING & LICENSE LAMPS

## Tail, Parking & License Lamps (2)

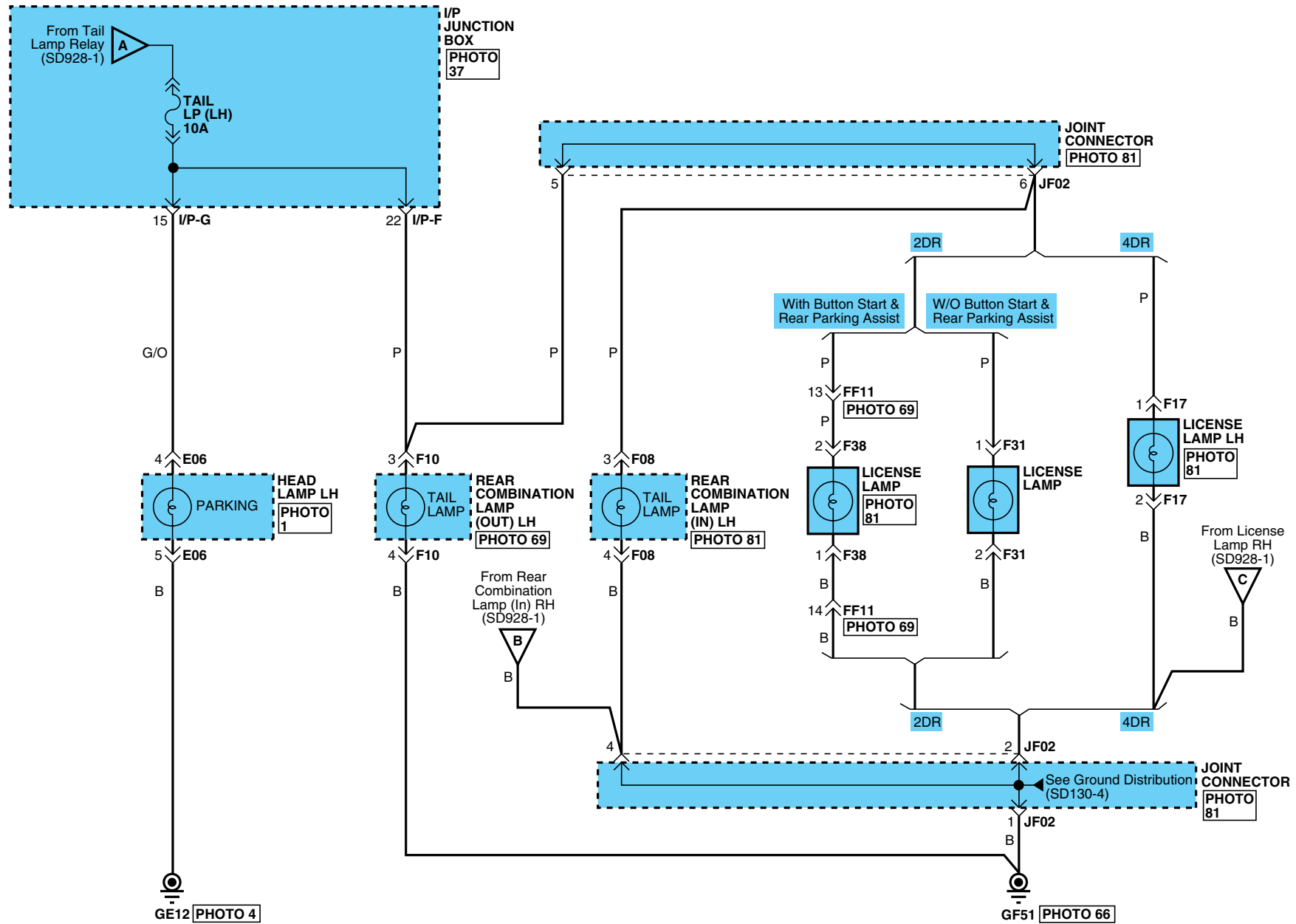
SD928-2

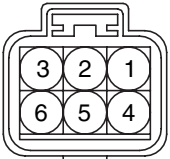

# TAIL, PARKING & LICENSE LAMPS

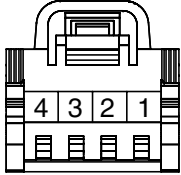
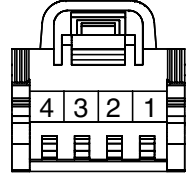
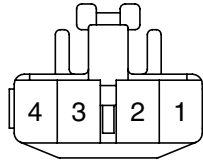
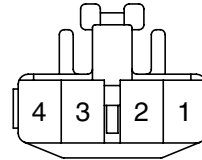
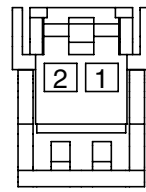
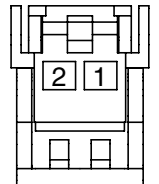
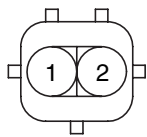
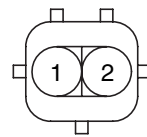
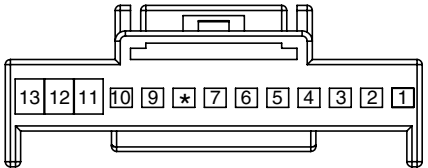
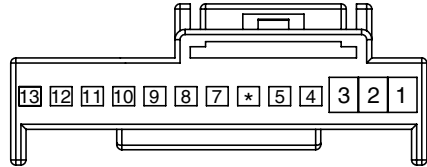
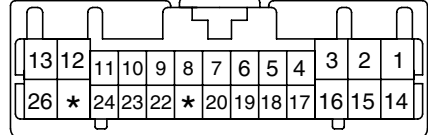
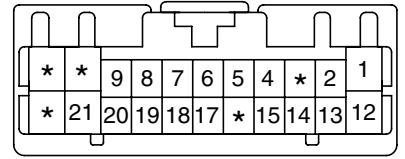
Tail, Parking & License Lamps (3)			SD928-3
<p><b>CGG51</b></p>  <p>KUM_NMWP_06F_B</p>	<p><b>CHG51</b></p>  <p>KUM_NMWP_06F_B</p>	<p><b>E06</b></p>  <p>KUM_NMWP_06F_B</p>	<p><b>F08</b></p>  <p>KET_62C_04F_W</p>
<p><b>F09</b></p>  <p>KET_62C_04F_W</p>	<p><b>F10</b></p>  <p>KET_090II_04F_W</p>	<p><b>F11</b></p>  <p>KET_090II_04F_W</p>	<p><b>F17</b></p>  <p>KET_060_02F_BR_A</p>
<p><b>F18</b></p>  <p>KET_060_02F_BR_A</p>	<p><b>F31</b></p>  <p>AMP_EJWP_02M_B</p>	<p><b>F38</b></p>  <p>AMP_EJWP_02M_B</p>	<p><b>M02-L</b></p>  <p>KET_0409_13F_W</p>
<p><b>M03-L</b></p>  <p>KET_0409_13F_B</p>	<p><b>M04-A</b></p>  <p>KET_0407_26F_W</p>	<p><b>M04-D</b></p>  <p>KET_0407_22F_W</p>	<p><b>BLANK</b></p>

**TAIL, PARKING & LICENSE LAMPS**

**Tail, Parking & License Lamps (4)**

**SD928-4**

**MEMO**

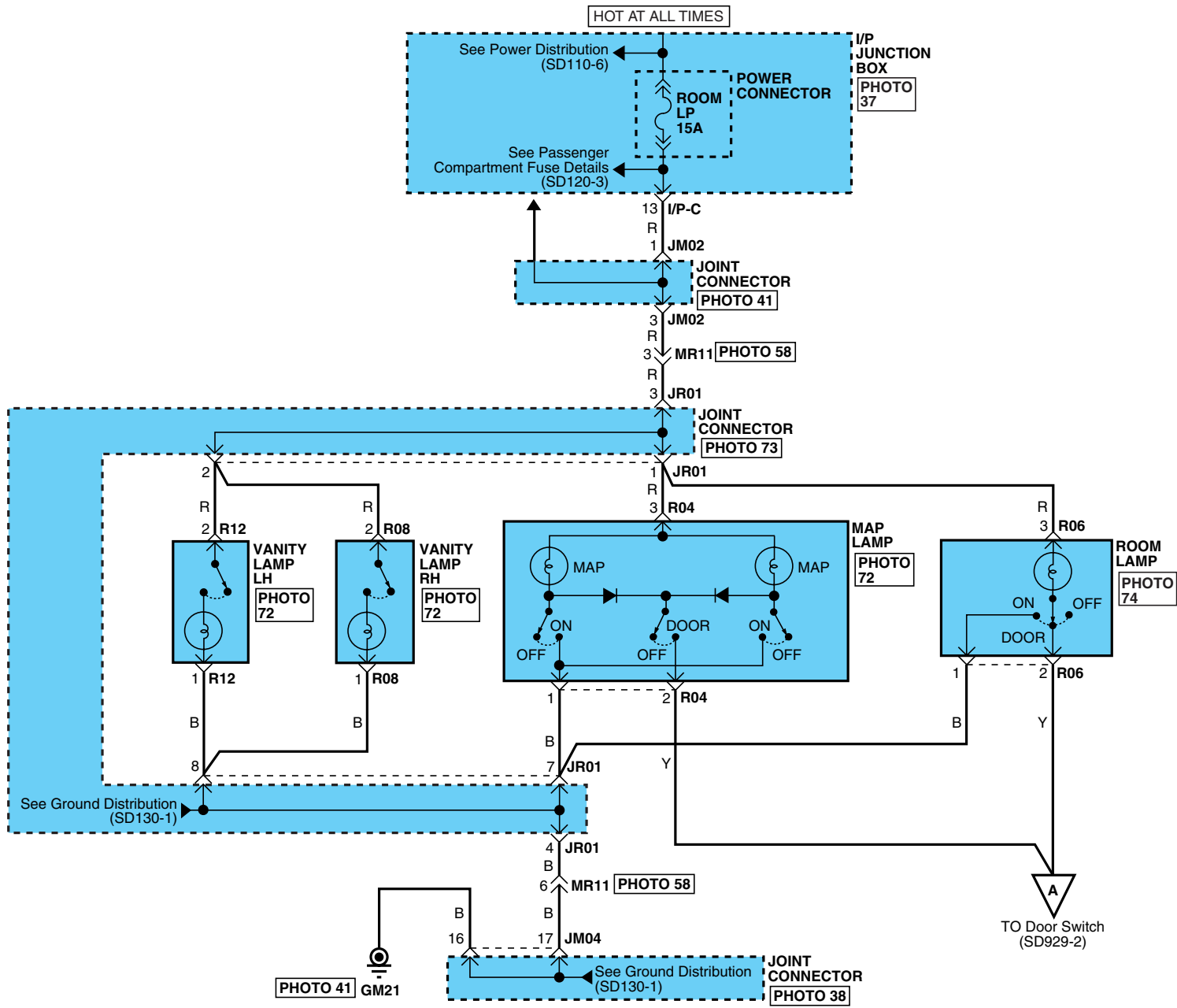

# COURTESY & TRUNK LAMPS

## Courtesy & Trunk Lamps (2)

SD929-2

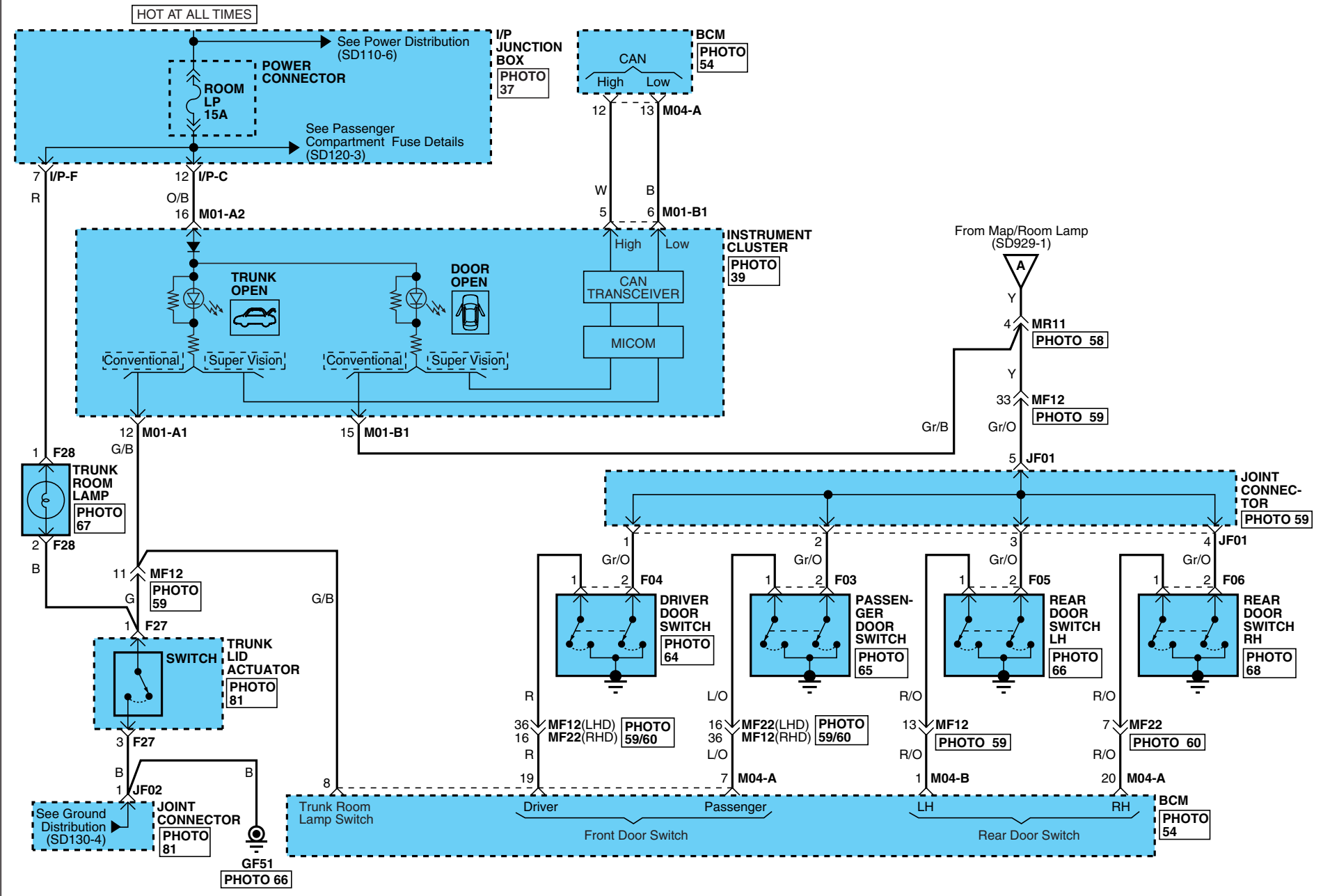

**COURTESY & TRUNK LAMPS**

**Courtesy & Trunk Lamps (3) SD929-3**

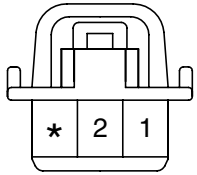
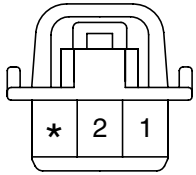
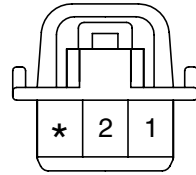
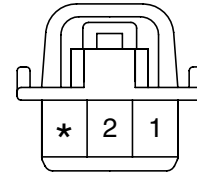
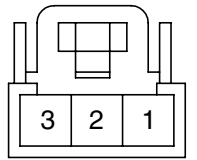
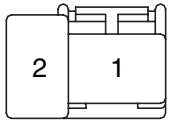
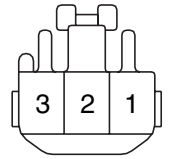
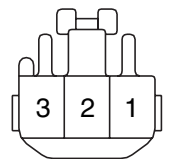
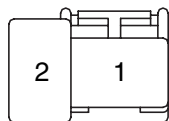
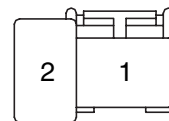
<p><b>F03</b></p>  <p>KET_62C03F_W_DR</p>	<p><b>F04</b></p>  <p>KET_62C03F_W_DR</p>	<p><b>F05</b></p>  <p>KET_62C03F_W_DR</p>	<p><b>F06</b></p>  <p>KET_62C03F_W_DR</p>																																																														
<p><b>F27</b></p>  <p>AMP_070_03F_W_HOR</p>	<p><b>F28</b></p>  <p>AMP_PLM2_02F_B_DL</p>	<p><b>M01-A1</b></p> <table border="1" style="margin: auto;"> <tr><td>*</td><td>7</td><td>6</td><td>*</td><td>4</td><td>3</td><td>2</td><td>1</td></tr> <tr><td>16</td><td>*</td><td>14</td><td>13</td><td>12</td><td>11</td><td>10</td><td>*</td></tr> </table> <p>AMP_040M2_16F_W</p>	*	7	6	*	4	3	2	1	16	*	14	13	12	11	10	*	<p><b>M01-A2</b></p> <table border="1" style="margin: auto;"> <tr><td>10</td><td>9</td><td>8</td><td>7</td><td>6</td><td>*</td><td>4</td><td>3</td><td>2</td><td>1</td></tr> <tr><td>20</td><td>19</td><td>18</td><td>*</td><td>16</td><td>*</td><td>14</td><td>*</td><td>*</td><td>11</td></tr> </table> <p>AMP_040M2_20F_B</p>	10	9	8	7	6	*	4	3	2	1	20	19	18	*	16	*	14	*	*	11																										
*	7	6	*	4	3	2	1																																																										
16	*	14	13	12	11	10	*																																																										
10	9	8	7	6	*	4	3	2	1																																																								
20	19	18	*	16	*	14	*	*	11																																																								
<p><b>M01-B1</b></p> <table border="1" style="margin: auto;"> <tr><td>10</td><td>*</td><td>8</td><td>*</td><td>6</td><td>5</td><td>4</td><td>3</td><td>2</td><td>1</td></tr> <tr><td>*</td><td>19</td><td>18</td><td>*</td><td>16</td><td>15</td><td>14</td><td>13</td><td>12</td><td>11</td></tr> </table> <p>AMP_040M1_20F_B</p>	10	*	8	*	6	5	4	3	2	1	*	19	18	*	16	15	14	13	12	11	<p><b>M04-A</b></p> <table border="1" style="margin: auto;"> <tr><td>13</td><td>12</td><td>11</td><td>10</td><td>9</td><td>8</td><td>7</td><td>6</td><td>5</td><td>4</td><td>3</td><td>2</td><td>1</td></tr> <tr><td>26</td><td>*</td><td>24</td><td>23</td><td>22</td><td>*</td><td>20</td><td>19</td><td>18</td><td>17</td><td>16</td><td>15</td><td>14</td></tr> </table> <p>KET_0407_26F_W</p>	13	12	11	10	9	8	7	6	5	4	3	2	1	26	*	24	23	22	*	20	19	18	17	16	15	14	<p><b>M04-B</b></p> <table border="1" style="margin: auto;"> <tr><td>8</td><td>7</td><td>6</td><td>5</td><td>4</td><td>3</td><td>2</td><td>1</td></tr> <tr><td>16</td><td>15</td><td>14</td><td>13</td><td>12</td><td>11</td><td>10</td><td>9</td></tr> </table> <p>KET_0407_16F_W</p>	8	7	6	5	4	3	2	1	16	15	14	13	12	11	10	9	<p><b>R04</b></p>  <p>KET_090I1_03F_W</p>
10	*	8	*	6	5	4	3	2	1																																																								
*	19	18	*	16	15	14	13	12	11																																																								
13	12	11	10	9	8	7	6	5	4	3	2	1																																																					
26	*	24	23	22	*	20	19	18	17	16	15	14																																																					
8	7	6	5	4	3	2	1																																																										
16	15	14	13	12	11	10	9																																																										
<p><b>R06</b></p>  <p>KET_090I1_03F_W</p>	<p><b>R08</b></p>  <p>AMP_PLM2_02F_B_DL</p>	<p><b>R12</b></p>  <p>AMP_PLM2_02F_B_DL</p>	<p><b>BLANK</b></p>																																																														



**COURTESY & TRUNK LAMPS**

**Courtesy & Trunk Lamps (4)**

**SD929-4**

**MEMO**

Indicators & Gauges (Conventional) (1)

SD940-1

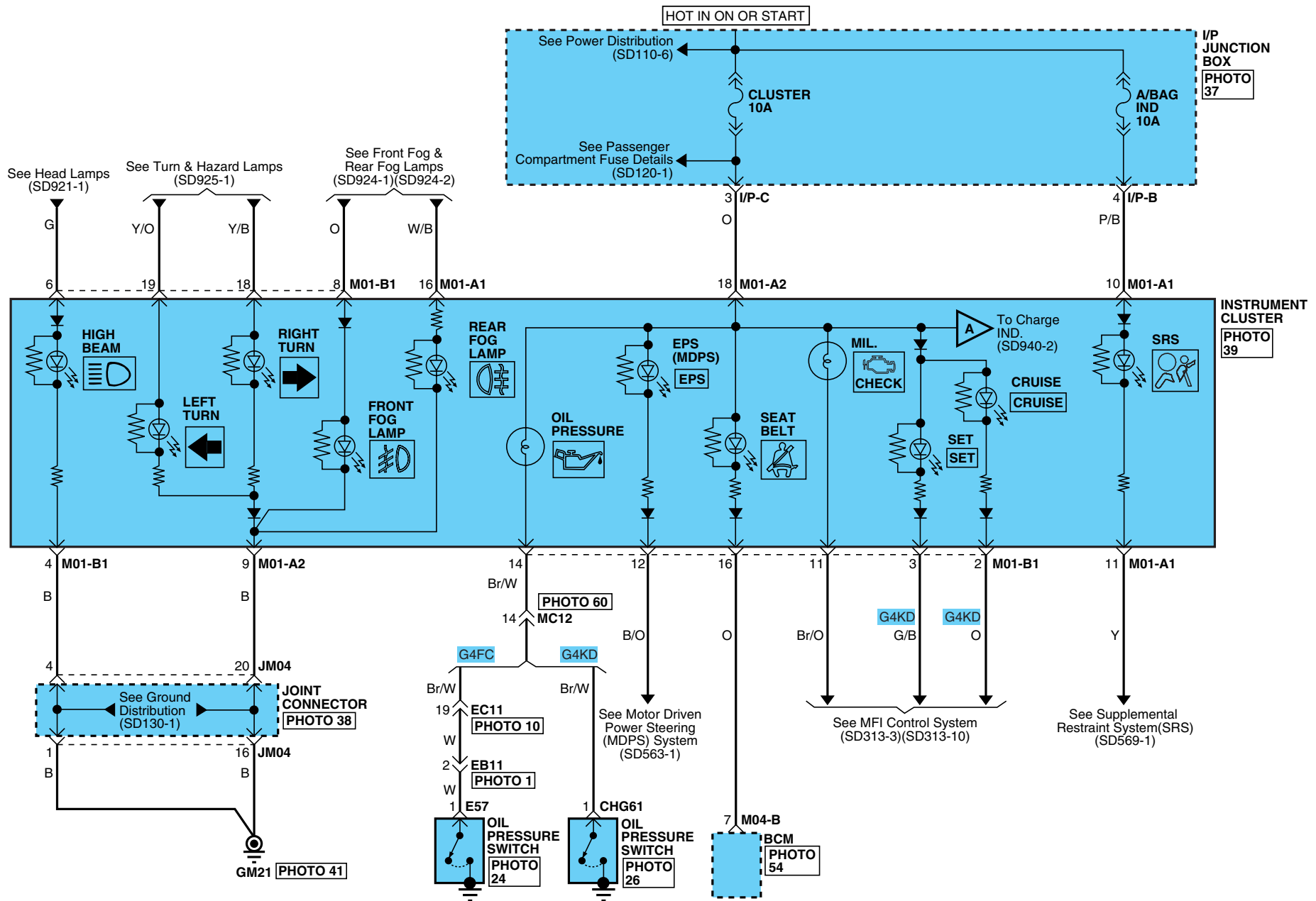

# INDICATORS & GAUGES

## Indicators & Gauges (Conventional) (2)

SD940-2

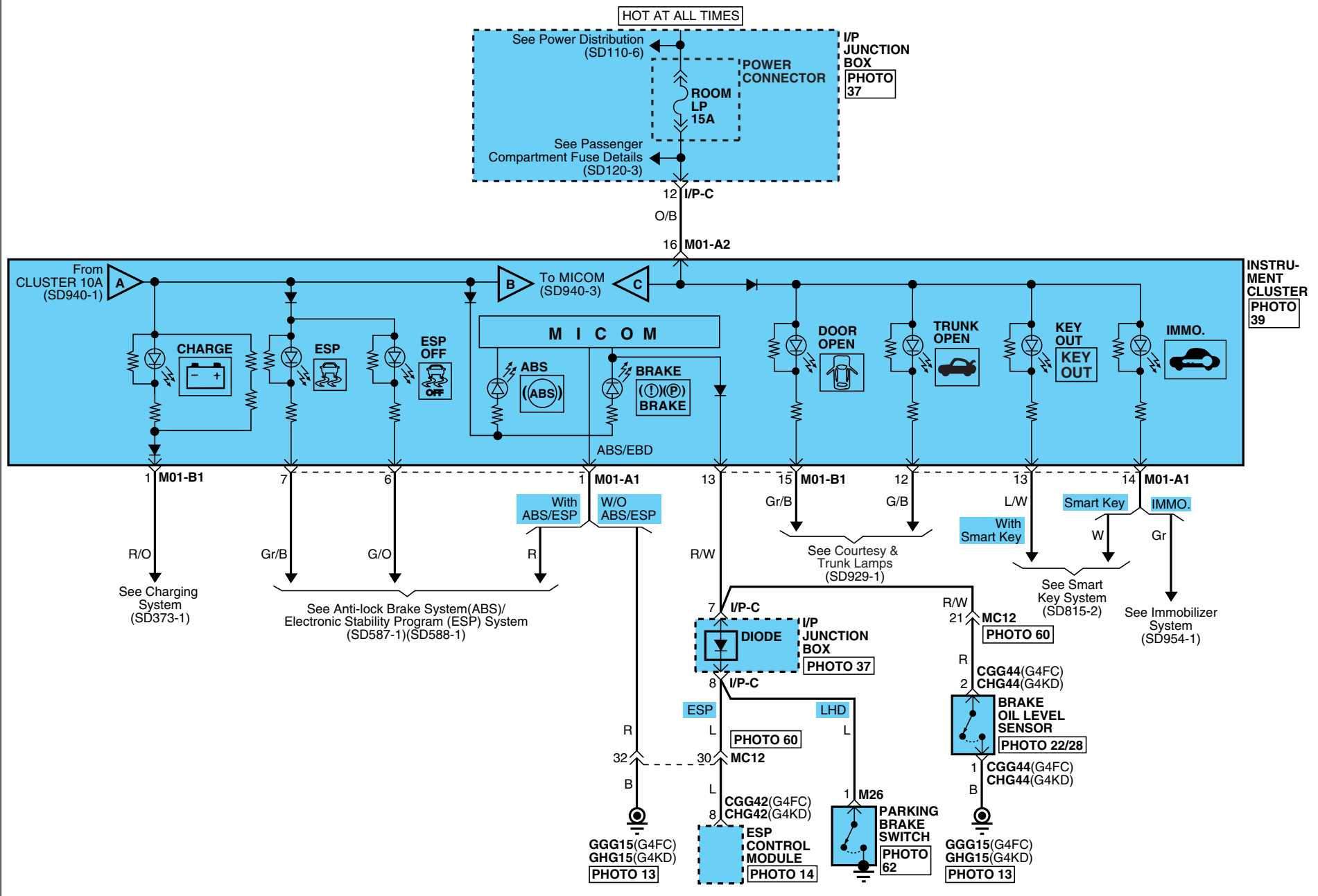

# INDICATORS & GAUGES

## Indicators & Gauges (Conventional) (3)



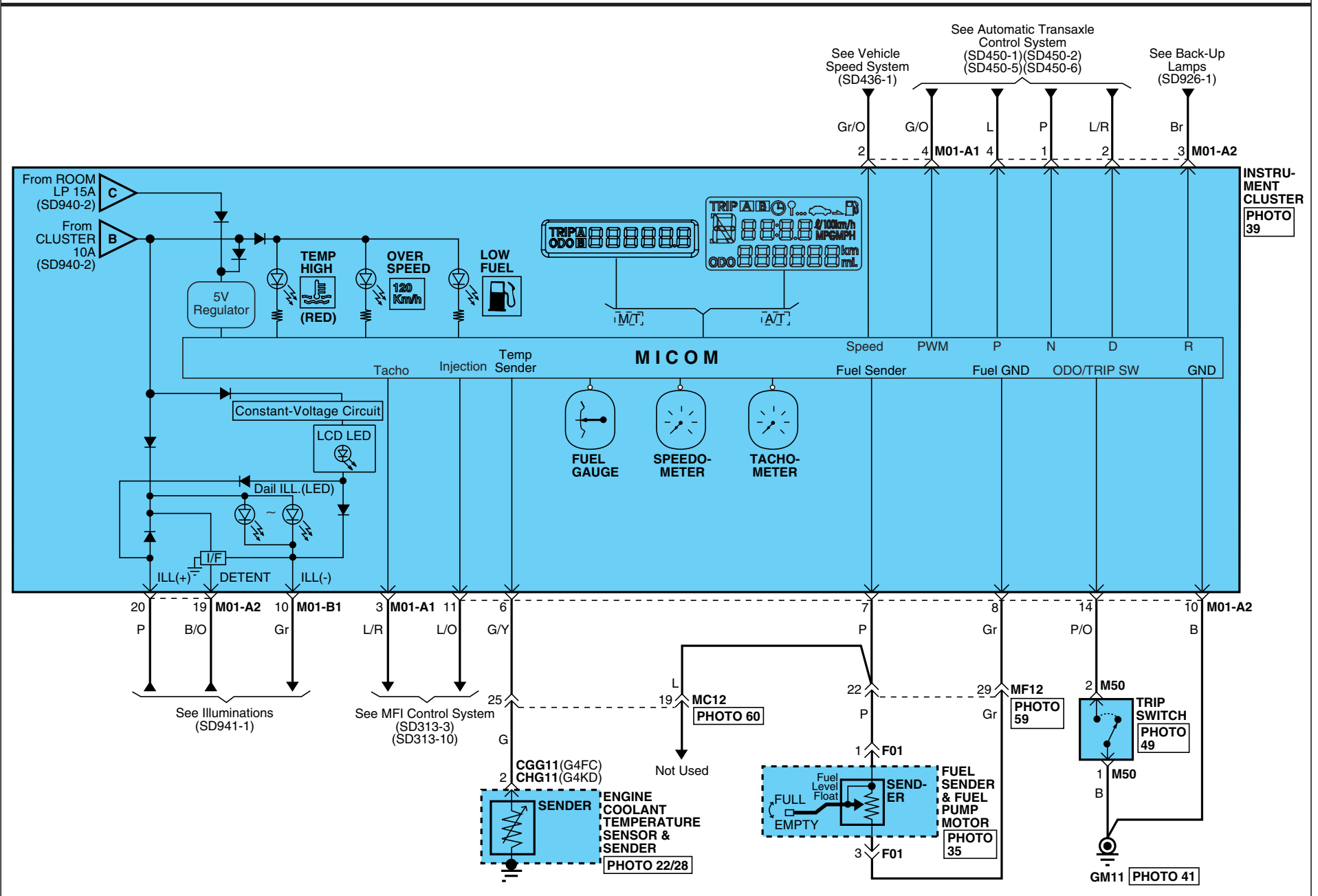

SD940-3

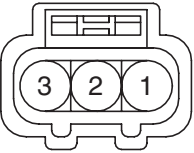
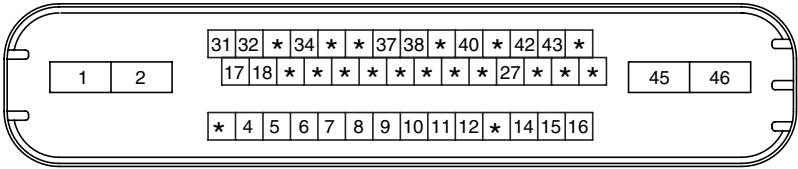

# INDICATORS & GAUGES

## Indicators & Gauges (Conventional) (4)

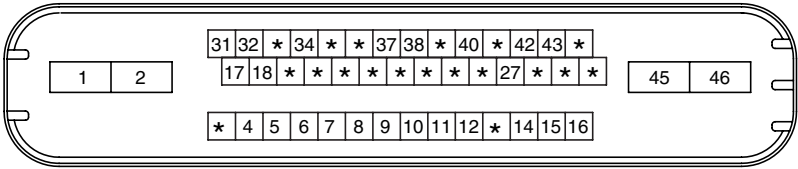
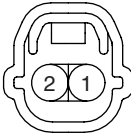
SD940-4

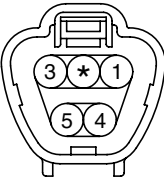
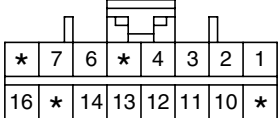
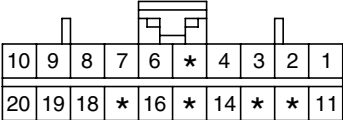
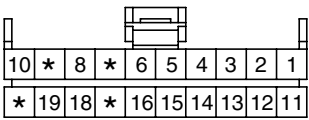
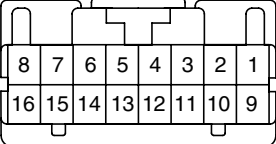
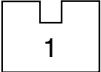
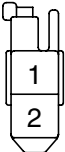
<p><b>CGG11</b></p>  <p>KUM_62Z_03F_B_WTS</p>	<p><b>CGG42</b></p>  <p>AMP_ESP_46F_B</p>		<p><b>CGG44</b></p>  <p>KET_SSD_02F_B</p>
<p><b>CHG11</b></p>  <p>AMP_EJWP_04F_B</p>	<p><b>CHG42</b></p>  <p>AMP_ESP_46F_B</p>		<p><b>CHG44</b></p>  <p>KET_SSD_02F_B</p>
<p><b>CHG61</b></p>  <p>KUM_NMWP_01F_B</p>	<p><b>E57</b></p>  <p>KUM_NMWP_01F_B</p>	<p><b>F01</b></p>  <p>KET_090IWP_05F_Gr_2</p>	<p><b>M01-A1</b></p>  <p>AMP_040M2_16F_W</p>
<p><b>M01-A2</b></p>  <p>AMP_040M2_20F_B</p>	<p><b>M01-B1</b></p>  <p>AMP_040M1_20F_B</p>	<p><b>M04-B</b></p>  <p>KET_0407_16F_W</p>	<p><b>M26</b></p>  <p>AMP_250DL_01F_B</p>
<p><b>M50</b></p>  <p>KET_090II_02F_W_SPK</p>	<p><b>BLANK</b></p>	<p><b>BLANK</b></p>	<p><b>BLANK</b></p>

# INDICATORS & GAUGES

## Indicators & Gauges (Super Vision) (1)

SD940-5

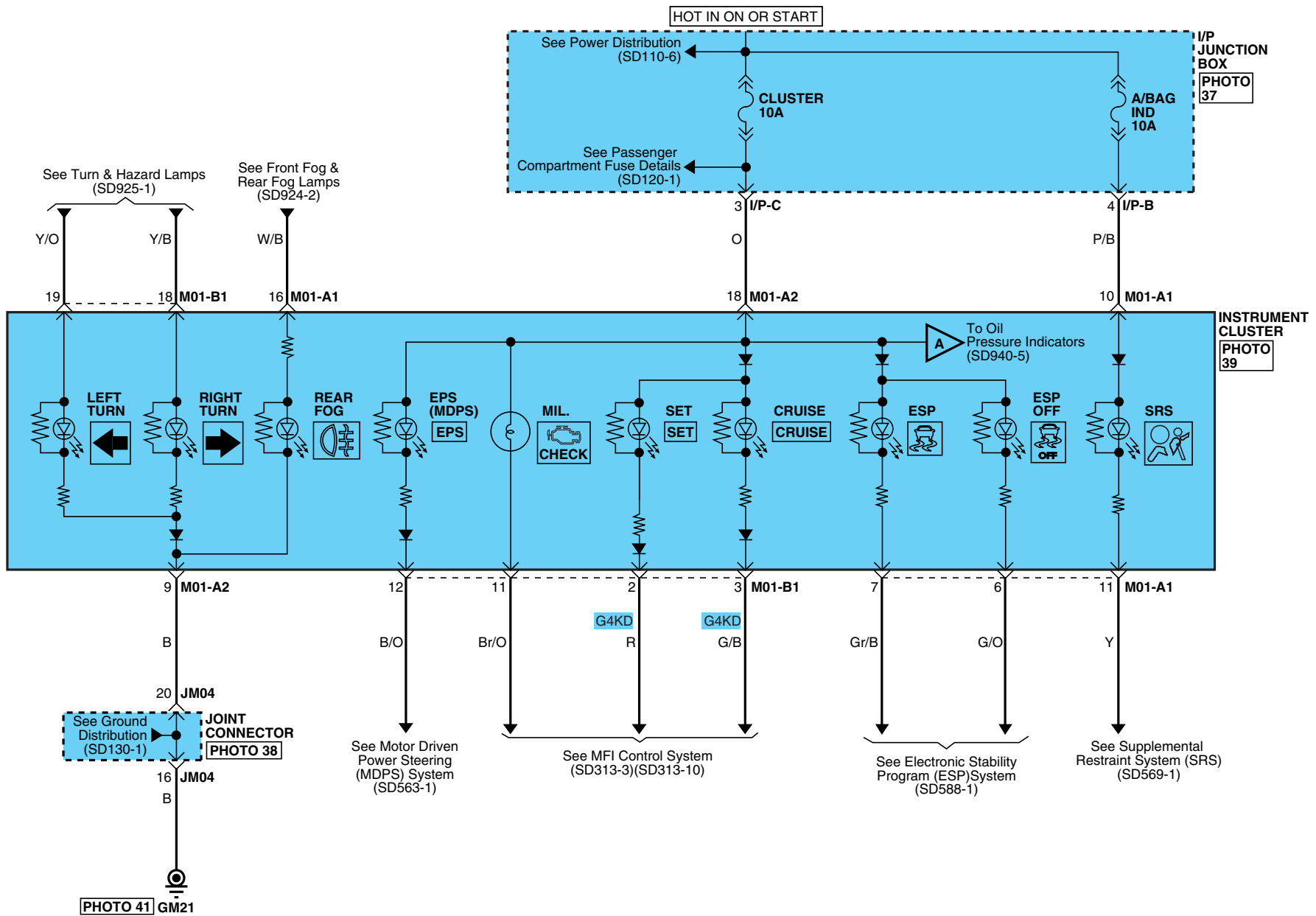

# INDICATORS & GAUGES

## Indicators & Gauges (Super Vision) (2)

SD940-6

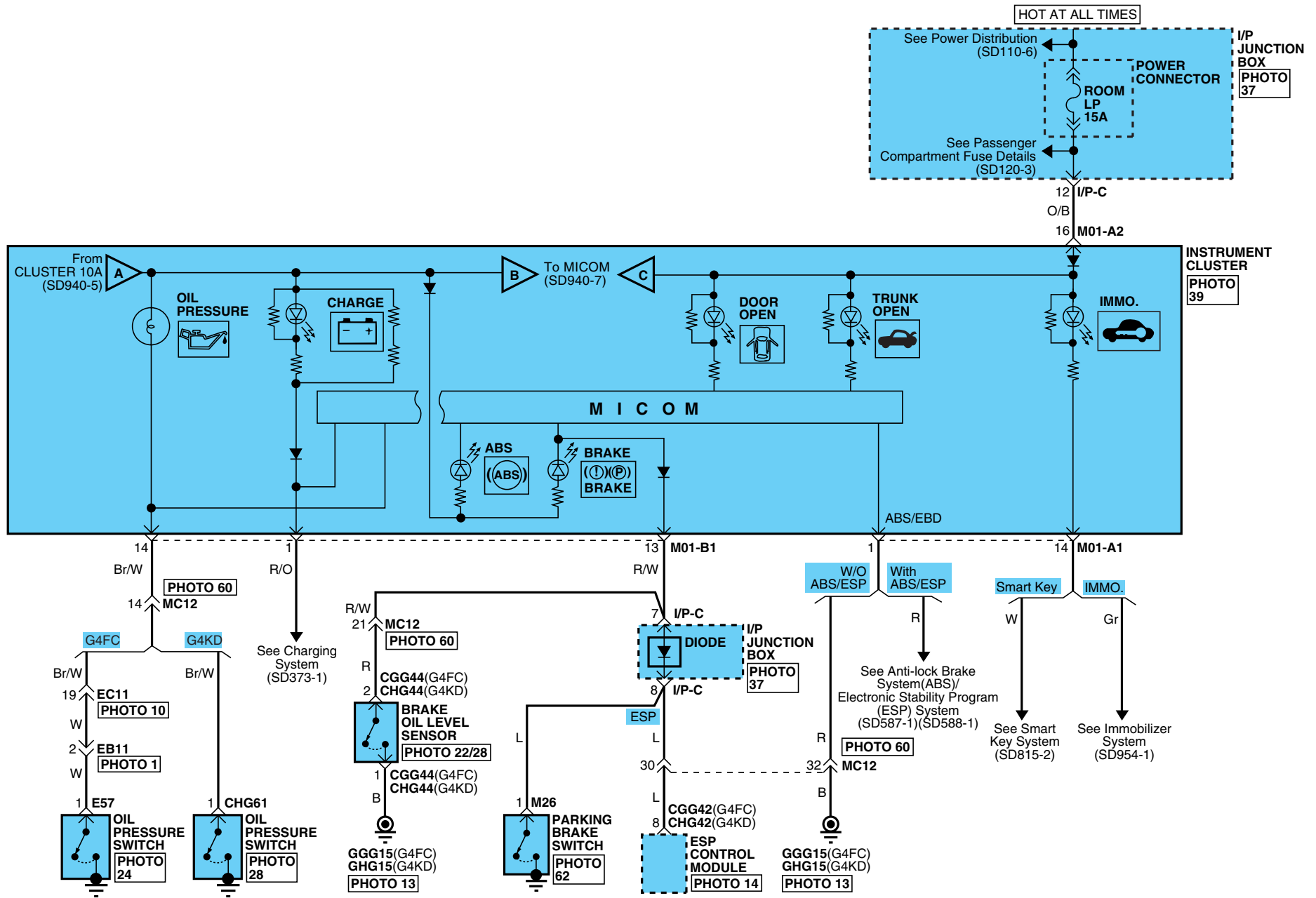

# INDICATORS & GAUGES

## Indicators & Gauges (Super Vision) (3)

SD940-7

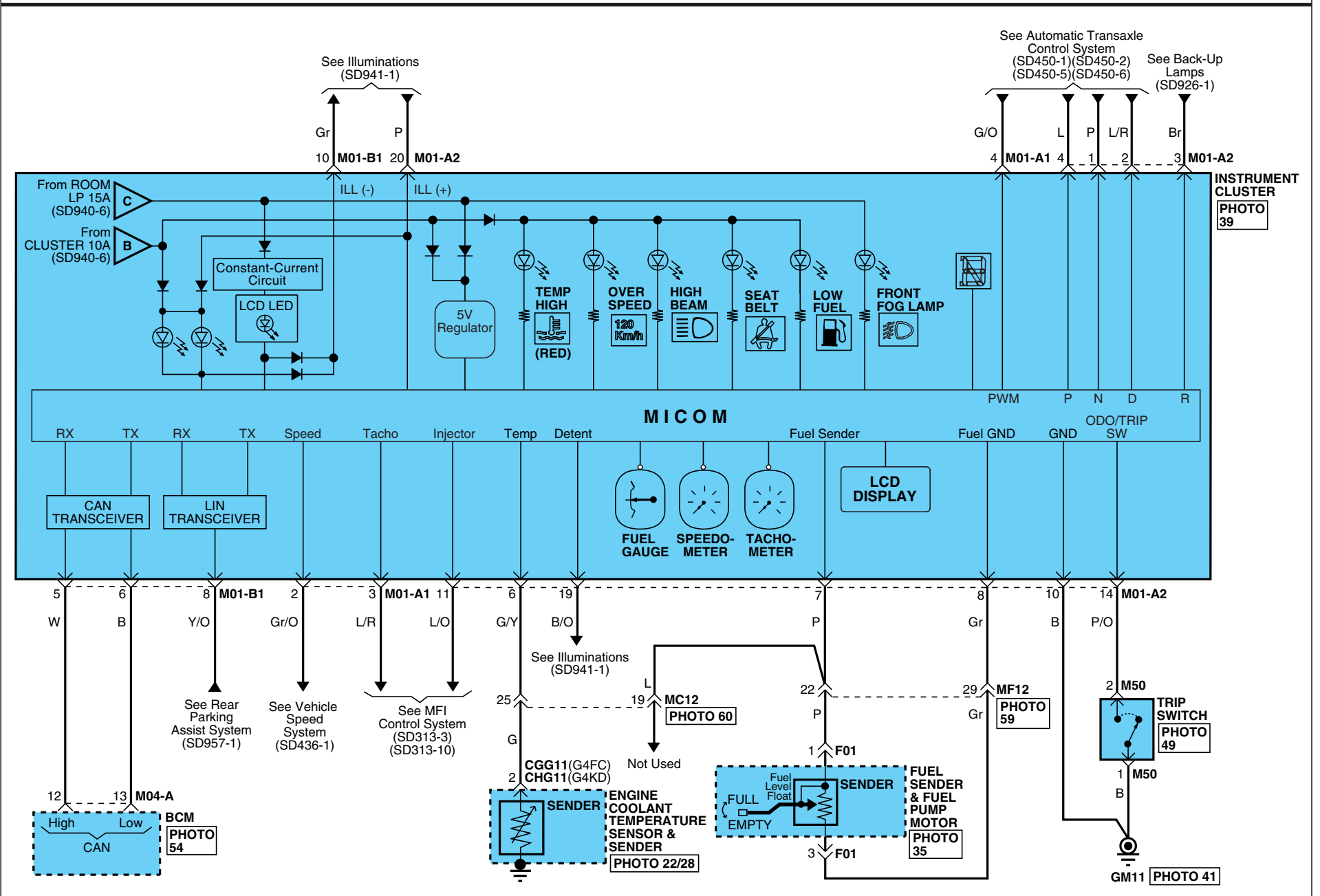



# INDICATORS & GAUGES

## Indicators & Gauges (Super Vision) (4)

SD940-8

**CGG11**

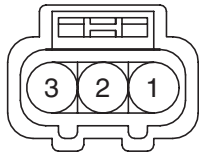

KUM\_62Z\_03F\_B\_WTS

**CGG42**

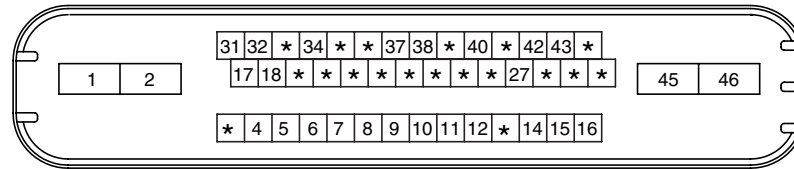

AMP\_ESP\_46F\_B

**CGG44**

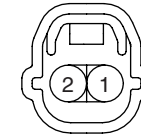

KET\_SSD\_02F\_B

**CHG11**

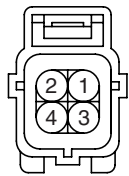

AMP\_EJWP\_04F\_B

**CHG42**

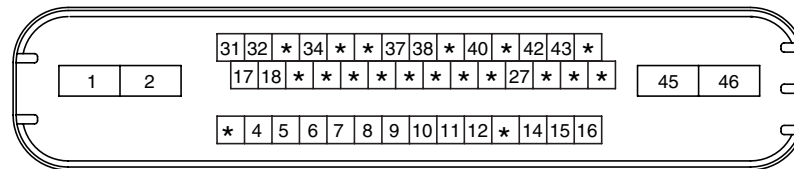

AMP\_ESP\_46F\_B

**CHG44**

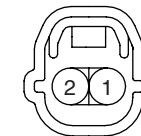

KET\_SSD\_02F\_B

**CHG61**



KUM\_NMWP\_01F\_B

**E57**



KUM\_NMWP\_01F\_B

**F01**

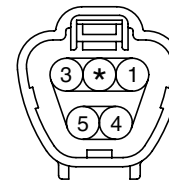

KET\_090IWP\_05F\_Gr\_2

**M01-A1**

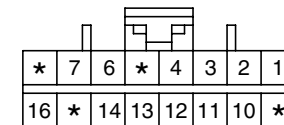

AMP\_040M2\_16F\_W

**M01-A2**

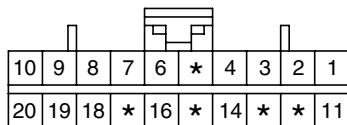

AMP\_040M2\_20F\_B

**M01-B1**

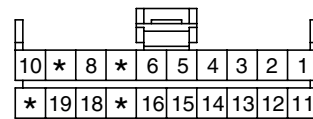

AMP\_040M1\_20F\_B

**M04-A**

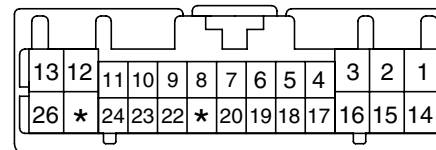

KET\_0407\_26F\_W

**M26**

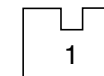

AMP\_250DL\_01F\_B

**M50**

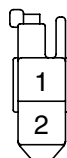

KET\_090II\_02F\_W\_SPK

**BLANK**

**BLANK**

**BLANK**

Illuminations (1)

SD941-1

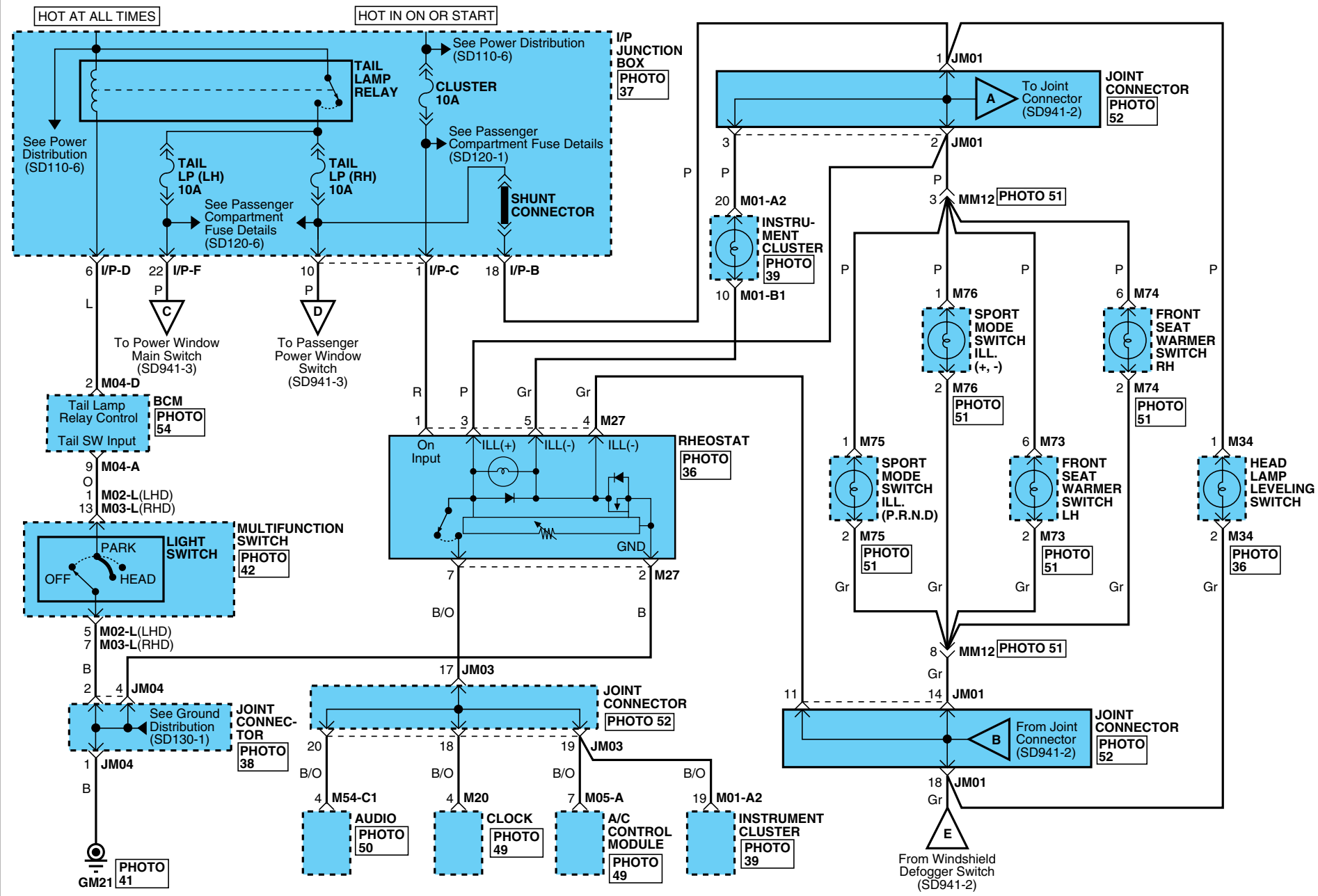

# ILLUMINATIONS

## Illuminations (2)

SD941-2

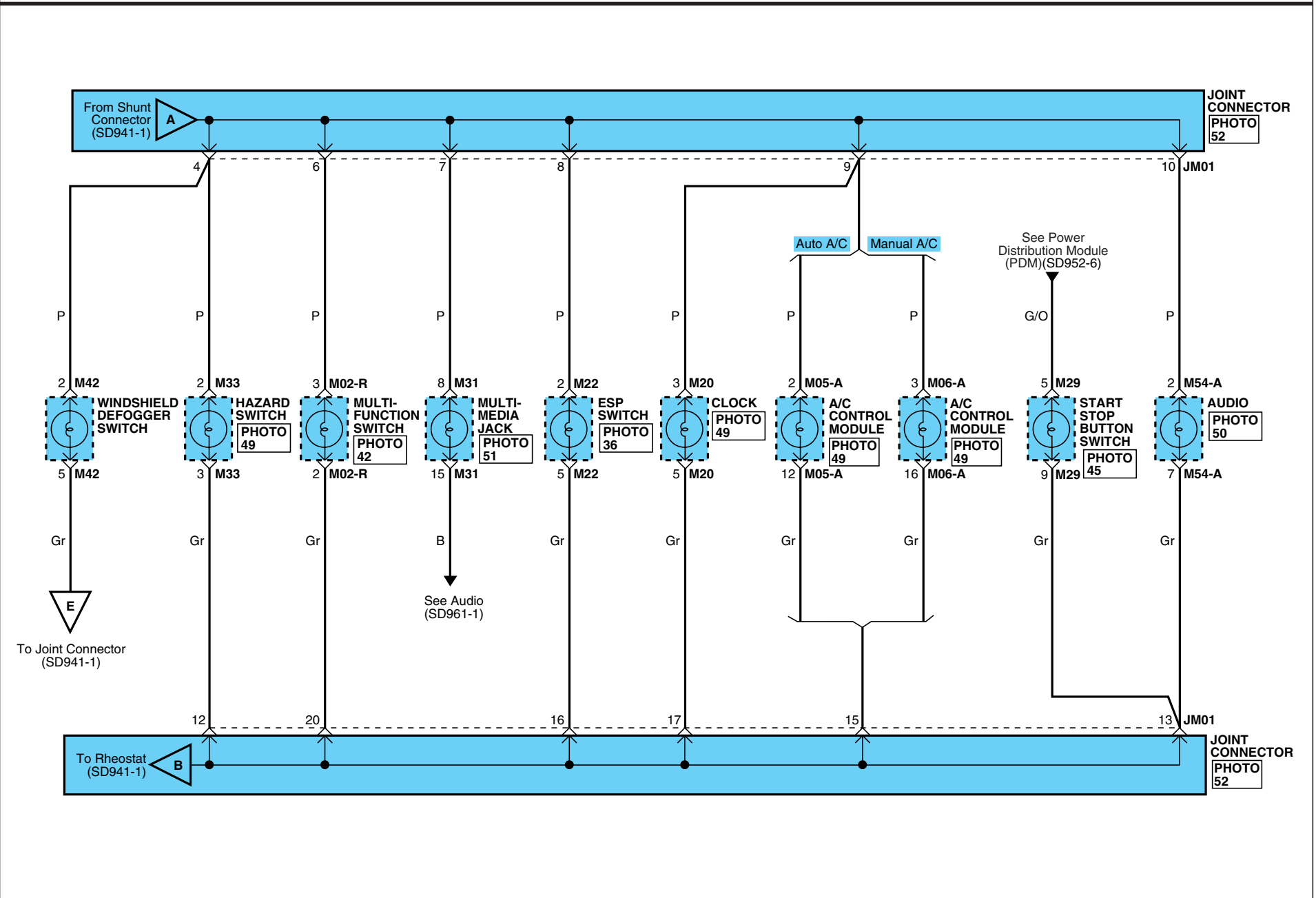

# ILLUMINATIONS

## Illuminations (3)

SD941-3

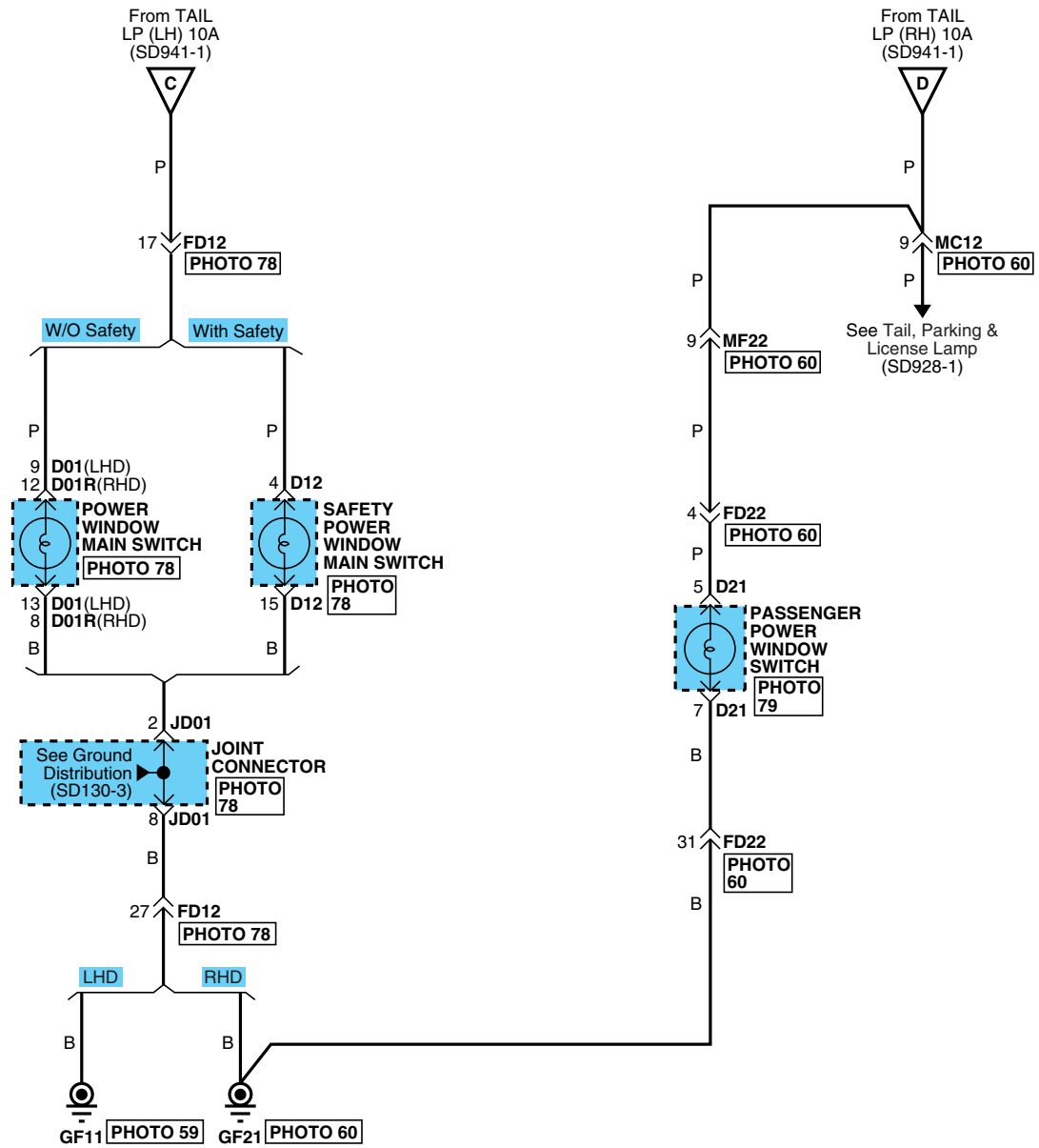

# ILLUMINATIONS

Illuminations (4)			SD941-4
<p><b>D01</b></p> <p>KET_090II_14F_W</p>	<p><b>D01R</b></p> <p>KET_090II_14F_W</p>	<p><b>D12</b></p> <p>KET_090III_16F_W</p>	<p><b>D21</b></p> <p>KET_090II_08F_W</p>
<p><b>M01-A2</b></p> <p>AMP_040M2_20F_B</p>	<p><b>M01-B1</b></p> <p>AMP_040M1_20F_B</p>	<p><b>M02-L</b></p> <p>KET_0409_13F_W</p>	<p><b>M02-R</b></p> <p>AMP_025_12F_W</p>
<p><b>M03-L</b></p> <p>KET_0409_13F_B</p>	<p><b>M04-A</b></p> <p>KET_0407_26F_W</p>	<p><b>M04-D</b></p> <p>KET_0407_22F_W</p>	<p><b>M05-A</b></p> <p>KET_0407_26F_W</p>
<p><b>M06-A</b></p> <p>KET_0407_26F_W</p>	<p><b>M20</b></p> <p>KET_91A_06F_W</p>	<p><b>M22</b></p> <p>AMP_090III_06F_Y</p>	<p><b>M27</b></p> <p>KUM_CDR_07F_B</p>
<p><b>M29</b></p> <p>MLX_025_10F_B</p>	<p><b>M31</b></p> <p>KET_040III_16F_W</p>	<p><b>M33</b></p> <p>KET_090II_10F_W</p>	<p><b>M34</b></p> <p>KUM_CDR_05F_W</p>

# ILLUMINATIONS

## Illuminations (5)

SD941-5

**M42**

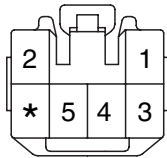

KET\_090II\_06F\_R

**M54-A**



AMP\_AUDIO\_08F\_GR\_D2

**M54-C1**

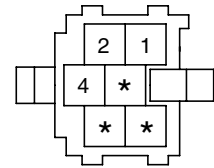

AMP\_AUDIO\_06F\_Y\_C1

**M73**

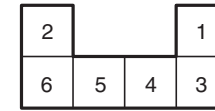

MG651044(KET)\_F

**M74**

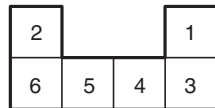

1743184(AMP)\_F

**M75**

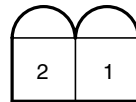

5264\_02\_MOLEX

**M76**

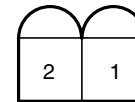

5264\_02\_MOLEX

**BLANK**

**ILLUMINATIONS**

**Illuminations (6)**

**SD941-6**

**MEMO**

Clock & Cigarette Lighter (Power Outlet) (1)

SD945-1

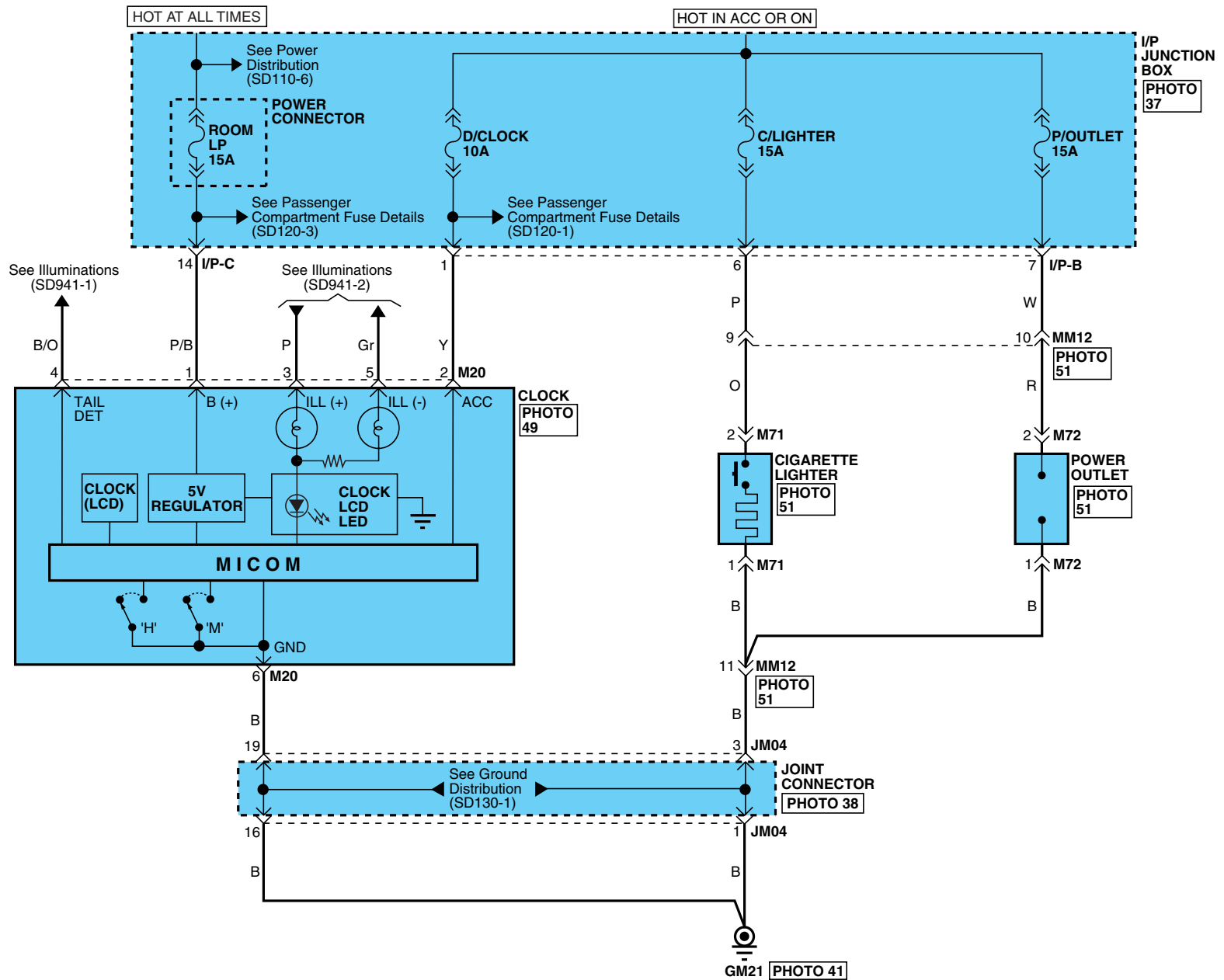



# CLOCK & CIGARETTE LIGHTER (POWER OUTLET)

## Clock & Cigarette Lighter (Power Outlet) (2)

SD945-2

M20

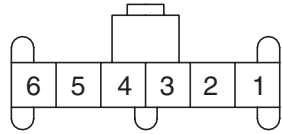

KET\_91A\_06F\_W

M71

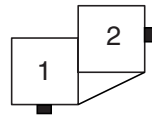

KET\_MG630685\_5

M72

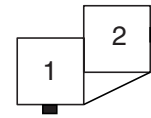

KET\_MG630685\_5

BLANK

Auto Lights (1)

SD951-1

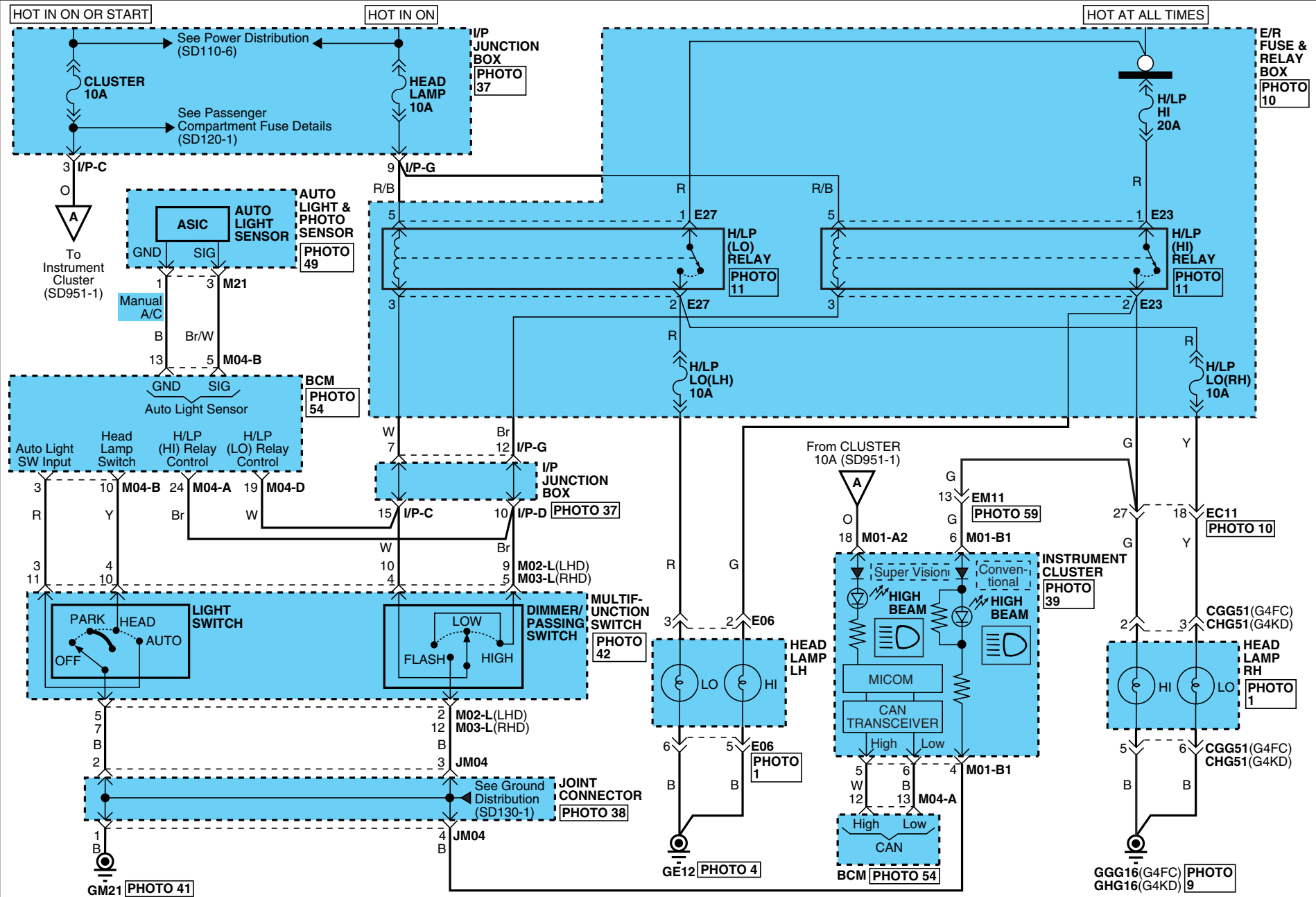

# AUTO LIGHTS

## Auto Lights (2)

SD951-2

**CGG51**



KUM\_NMWP\_06F\_B

**CHG51**

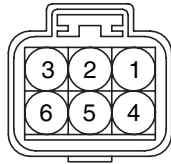

KUM\_NMWP\_06F\_B

**E06**

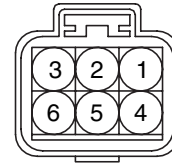

KUM\_NMWP\_06F\_B

**E23**

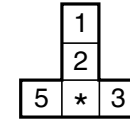

CR05F011

**E27**

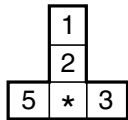

CR05F011

**M01-A2**

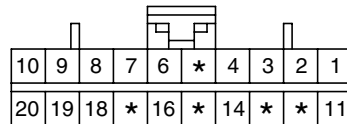

AMP\_040M2\_20F\_B

**M01-B1**

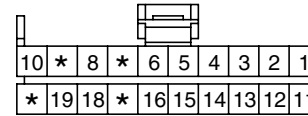

AMP\_040M1\_20F\_B

**M02-L**

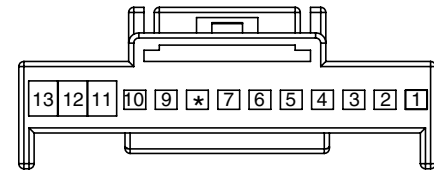

KET\_0409\_13F\_W

**M03-L**

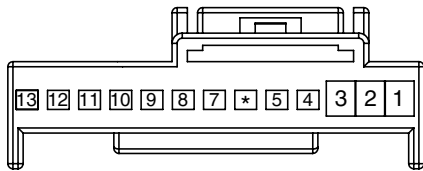

KET\_0409\_13F\_B

**M04-A**

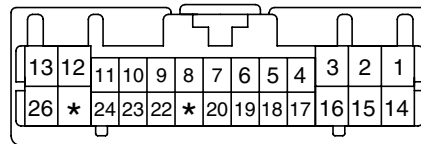

KET\_0407\_26F\_W

**M04-B**

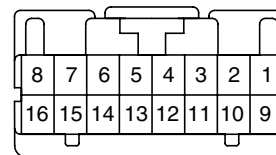

KET\_0407\_16F\_W

**M04-D**

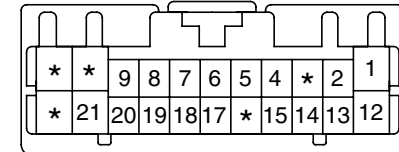

KET\_0407\_22F\_W

**M21**

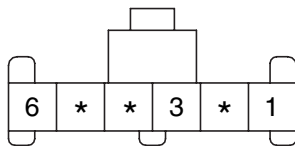

KET\_91A\_06F\_Gr\_1

**BLANK**

**BLANK**

**BLANK**

Body Control Module (BCM) System (1)

SD952-1

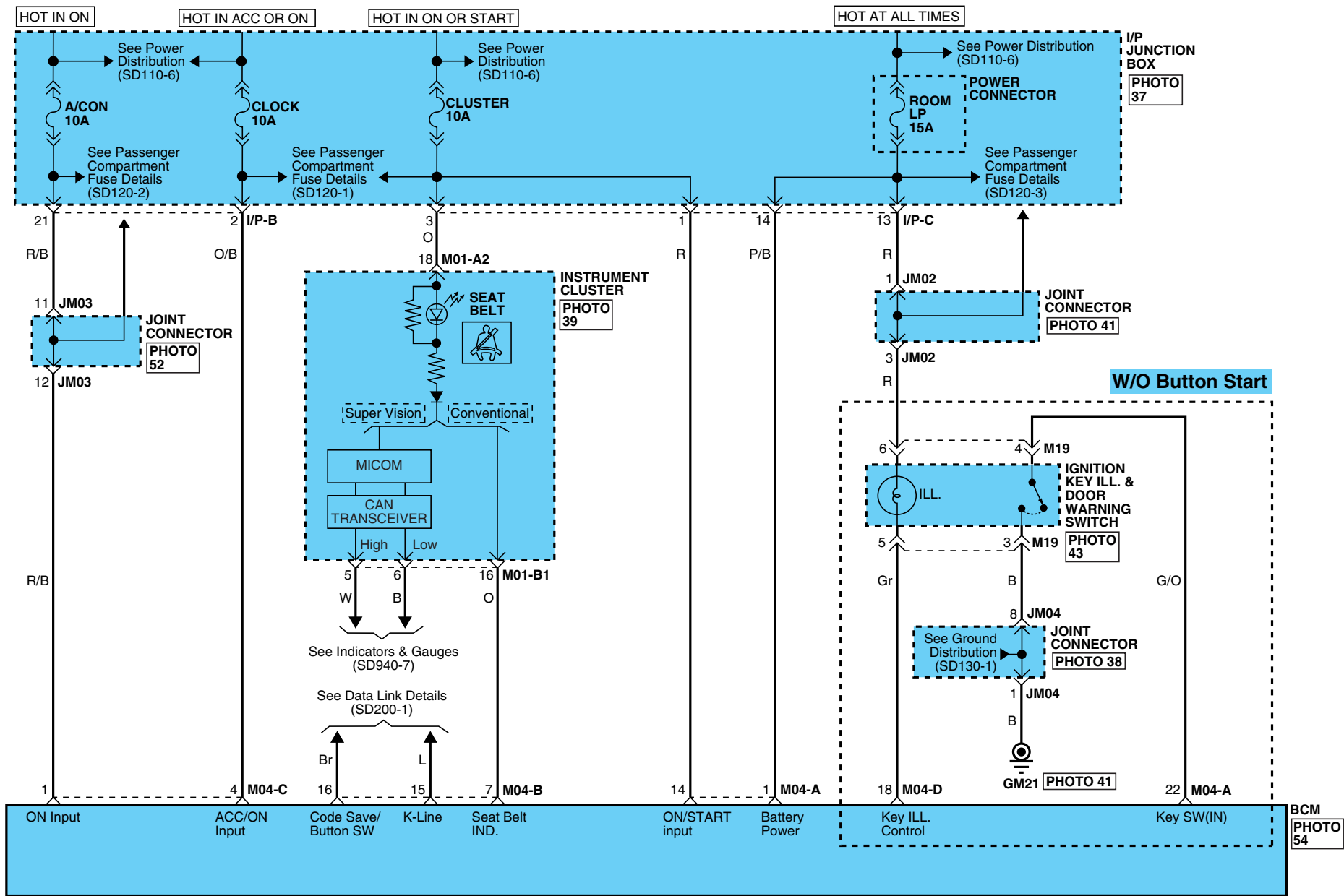

# BODY CONTROL MODULE (BCM) SYSTEM

## Body Control Module (BCM) System (2)

SD952-2

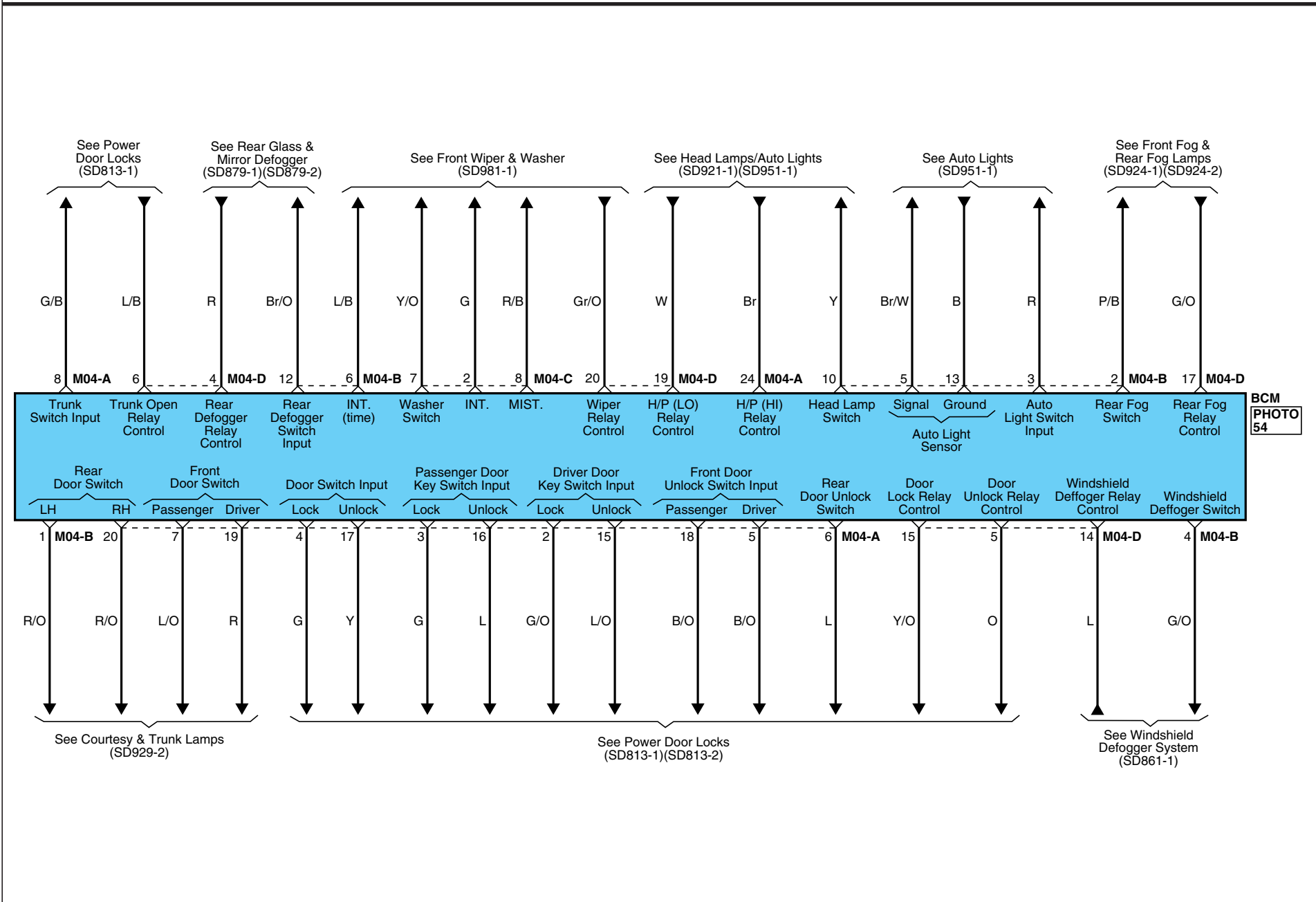

# BODY CONTROL MODULE (BCM) SYSTEM

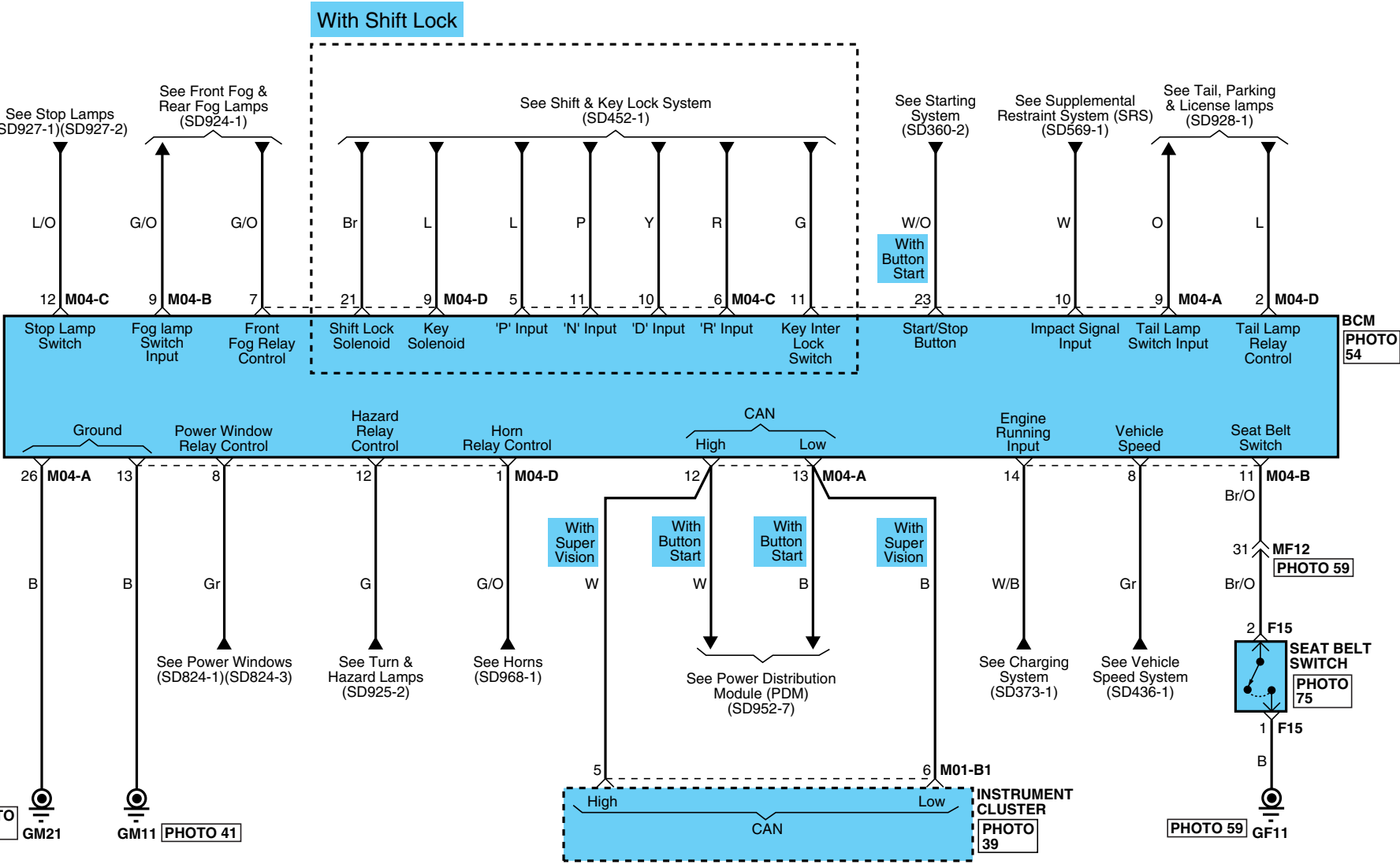

# BODY CONTROL MODULE (BCM) SYSTEM

## Body Control Module (BCM) System (4)

SD952-4

**F15**

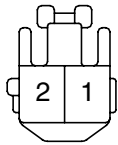

KET\_090II\_02F\_W\_T

**M01-A2**

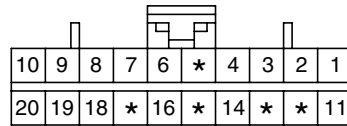

AMP\_040M2\_20F\_B

**M01-B1**

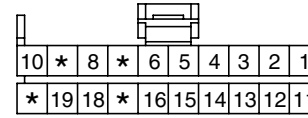

AMP\_040M1\_20F\_B

**M04-A**

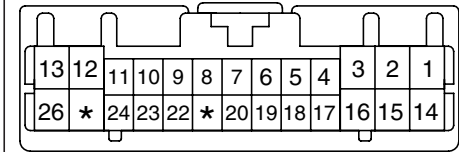

KET\_0407\_26F\_W

**M04-B**

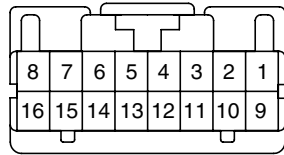

KET\_0407\_16F\_W

**M04-C**

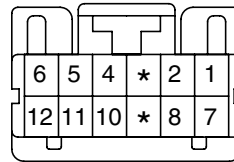

KET\_0407\_12F\_W

**M04-D**

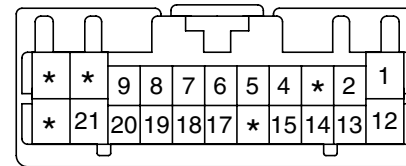

KET\_0407\_22F\_W

**M19**

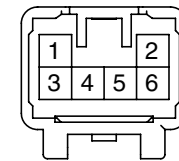

KET\_090III\_06M\_W

# POWER DISTRIBUTION MODULE (PDM)

E0CD63BA

## Power Distribution Module (PDM) (1)

SD952-5

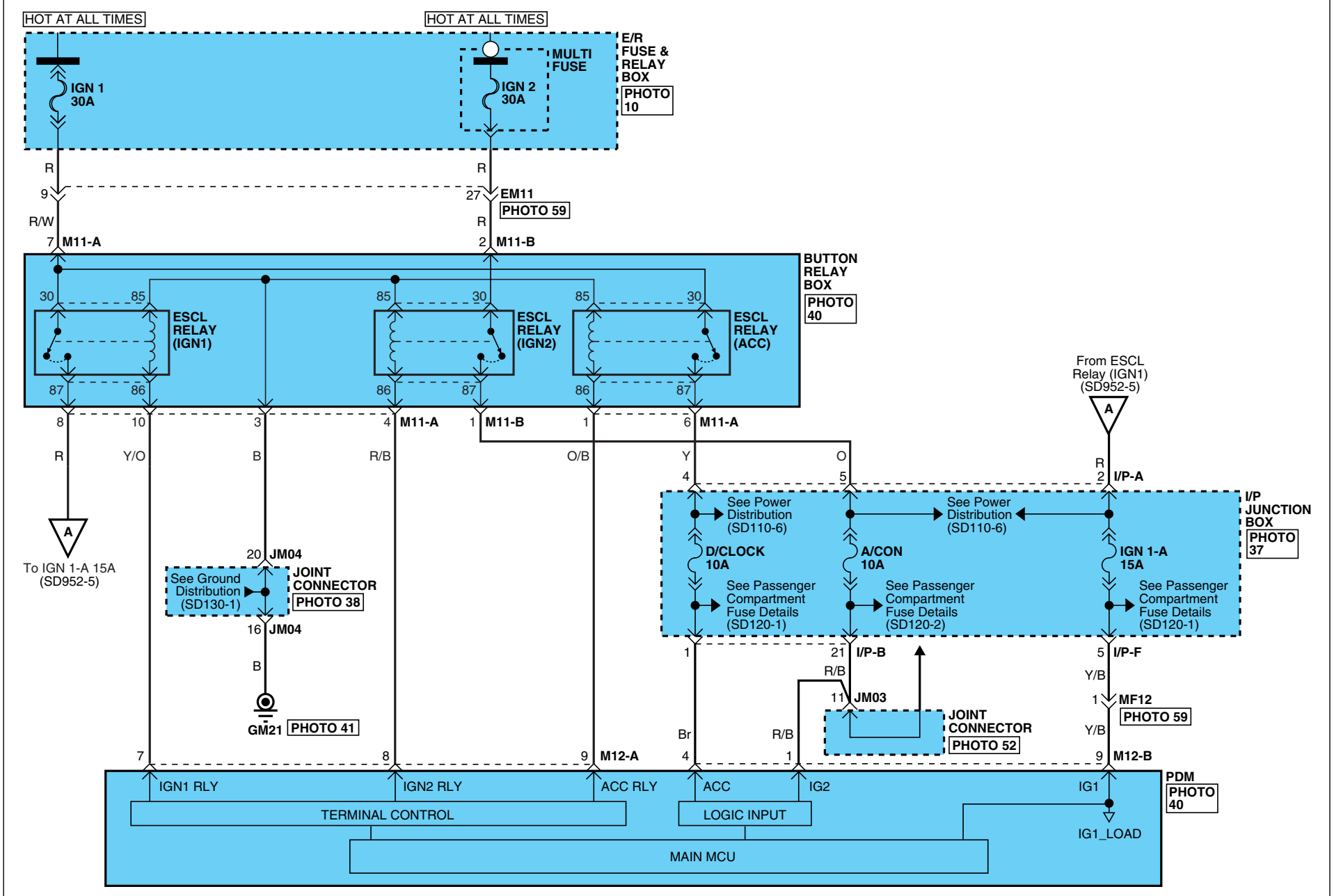



# POWER DISTRIBUTION MODULE (PDM)

## Power Distribution Module (PDM) (2)

SD952-6

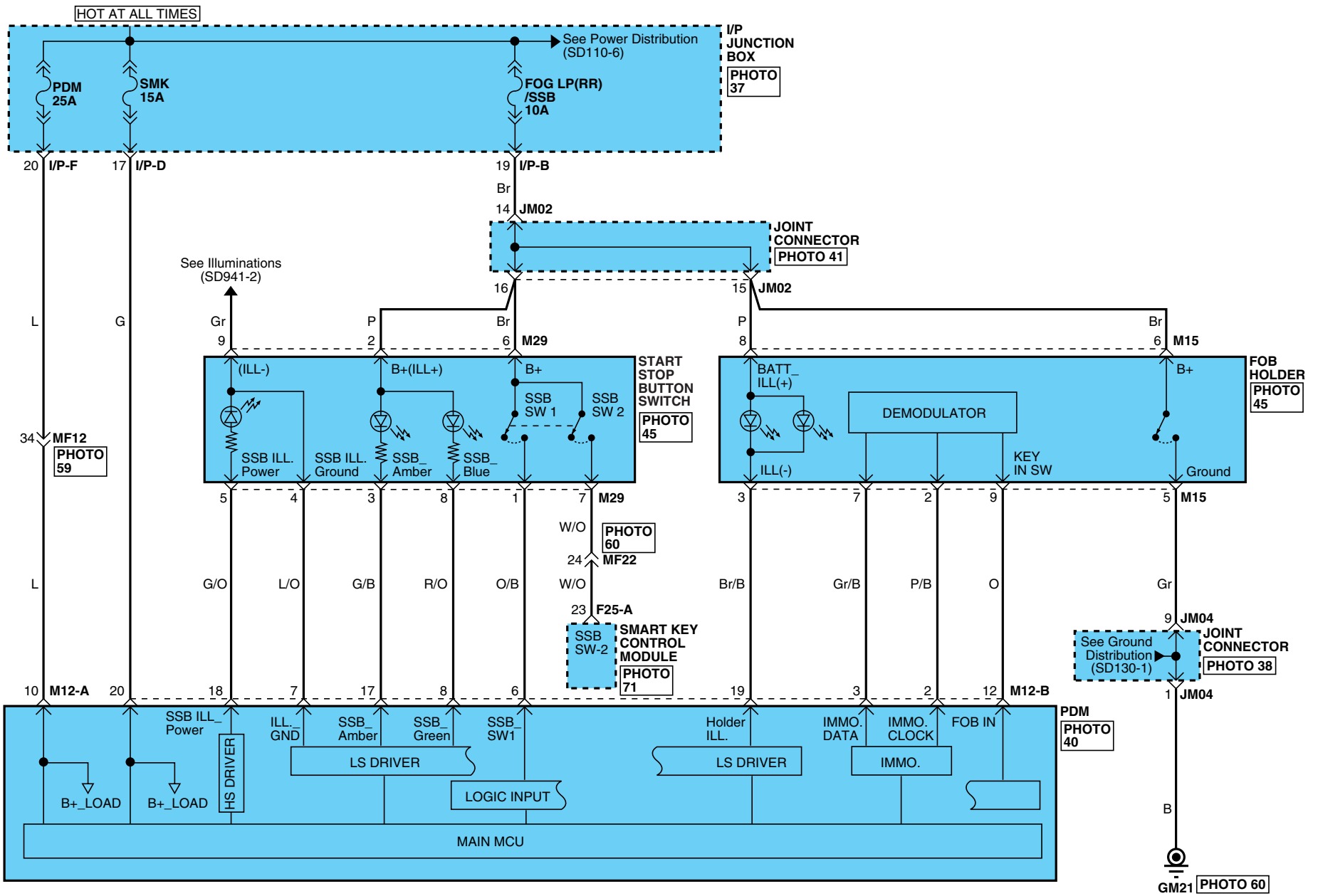

# POWER DISTRIBUTION MODULE (PDM)

## Power Distribution Module (PDM) (3)

SD952-7

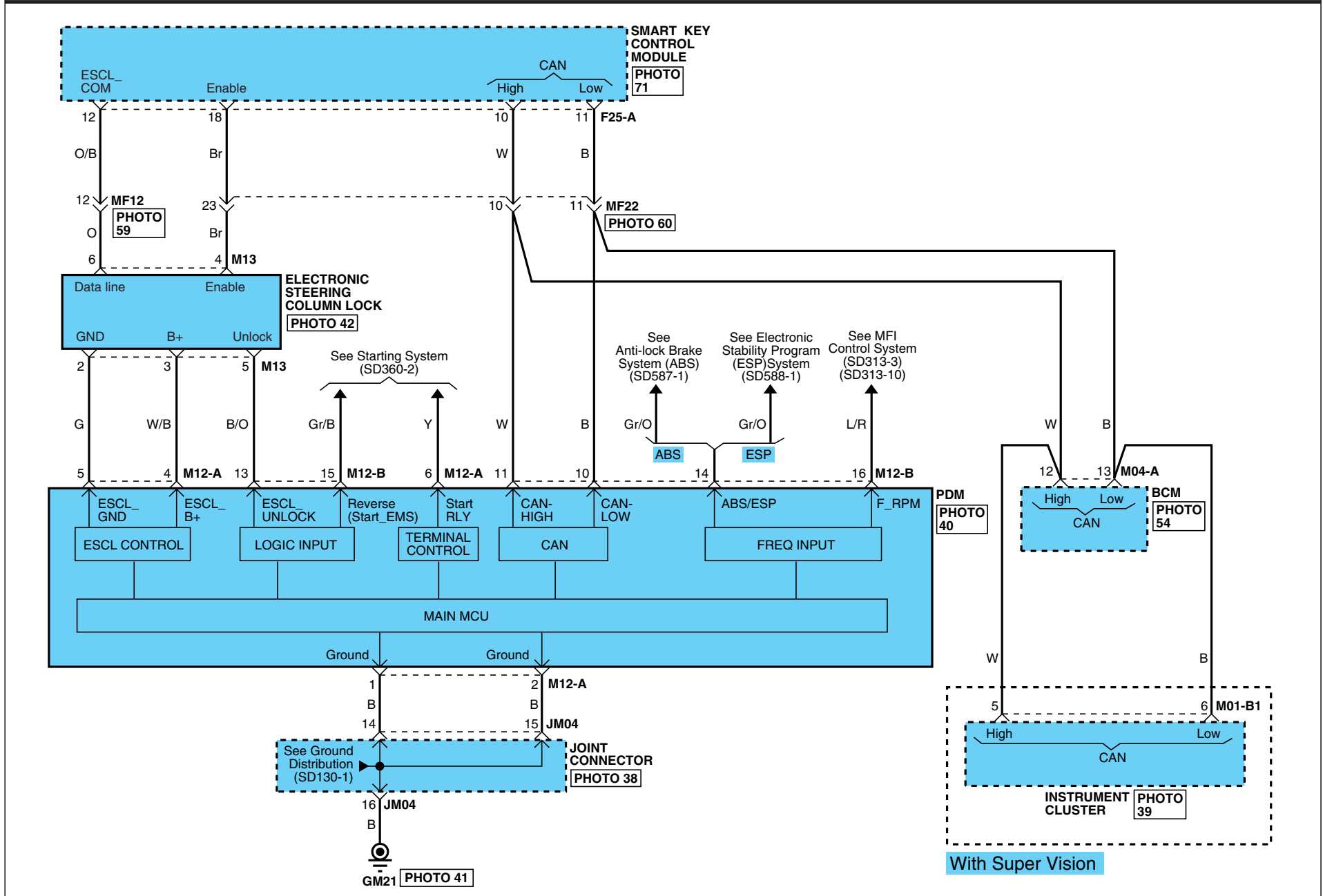

# POWER DISTRIBUTION MODULE (PDM)

Power Distribution Module (PDM) (4)			SD952-8
<p style="text-align: center;"><b>F25-A</b></p> <p style="text-align: center;">AMP_0407_26F_W_HD</p>	<p style="text-align: center;"><b>M01-B1</b></p> <p style="text-align: center;">AMP_040M1_20F_B</p>	<p style="text-align: center;"><b>M04-A</b></p> <p style="text-align: center;">KET_0407_26F_W</p>	<p style="text-align: center;"><b>M11-A</b></p> <p style="text-align: center;">AMP_0925_10F_W</p>
<p style="text-align: center;"><b>M11-B</b></p> <p style="text-align: center;">AMP_250JPT_02F_B</p>	<p style="text-align: center;"><b>M12-A</b></p> <p style="text-align: center;">KET_090II_10F_W</p>	<p style="text-align: center;"><b>M12-B</b></p> <p style="text-align: center;">KET_040III_20F_W</p>	<p style="text-align: center;"><b>M13</b></p> <p style="text-align: center;">KET_090II_06F_B</p>
<p style="text-align: center;"><b>M15</b></p> <p style="text-align: center;">YAZ_SP_10F_W</p>	<p style="text-align: center;"><b>M29</b></p> <p style="text-align: center;">MLX_025_10F_B</p>	<p><b>BLANK</b></p>	<p><b>BLANK</b></p>

Immobilizer System (1)

SD954-1

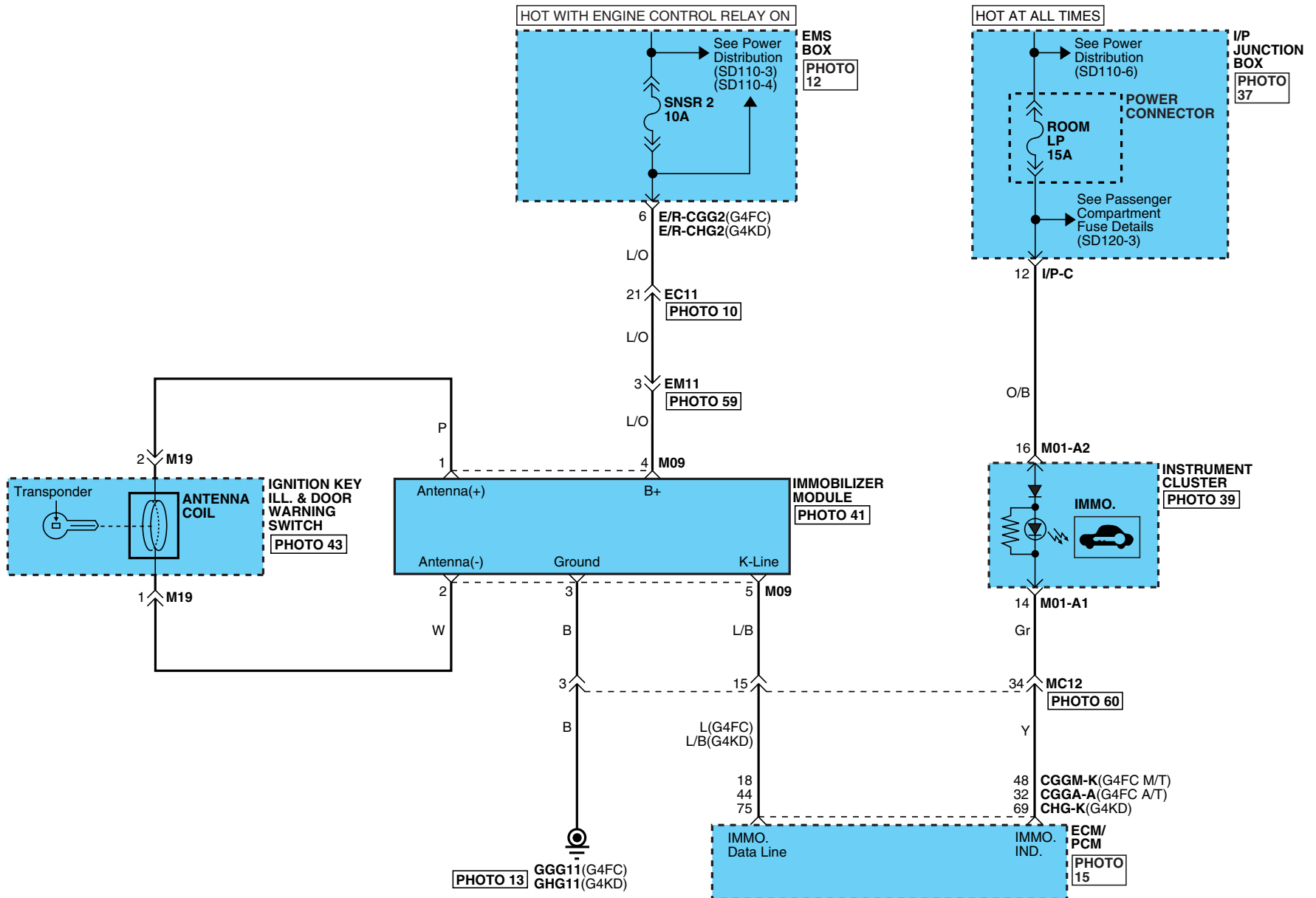

# IMMOBILIZER SYSTEM

## Immobilizer System (2)

SD954-2

**CGGA-A**

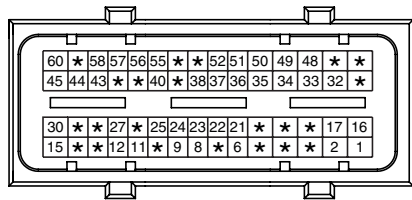

AMP\_ECU\_60F\_B

**CGGM-K**

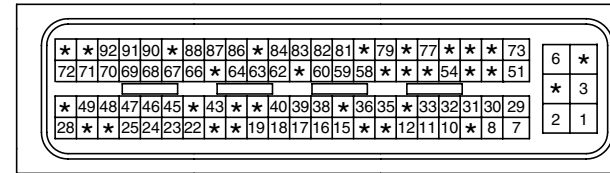

AMP\_ECU\_94F\_B

**CHG-K**

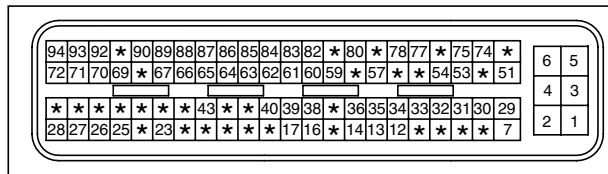

AMP\_ECU\_94F\_B

**M01-A1**

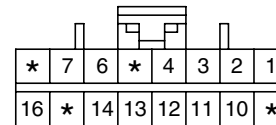

AMP\_040M2\_16F\_W

**M01-A2**

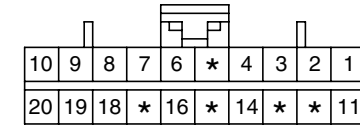

AMP\_040M2\_20F\_B

**M09**

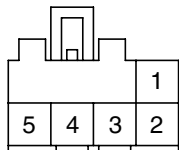

KUM\_CDR\_05F\_W

**M19**

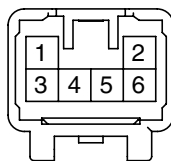

KET\_090III\_06M\_W

**BLANK**

**BLANK**

Rear Parking Assist System (1)

SD957-1

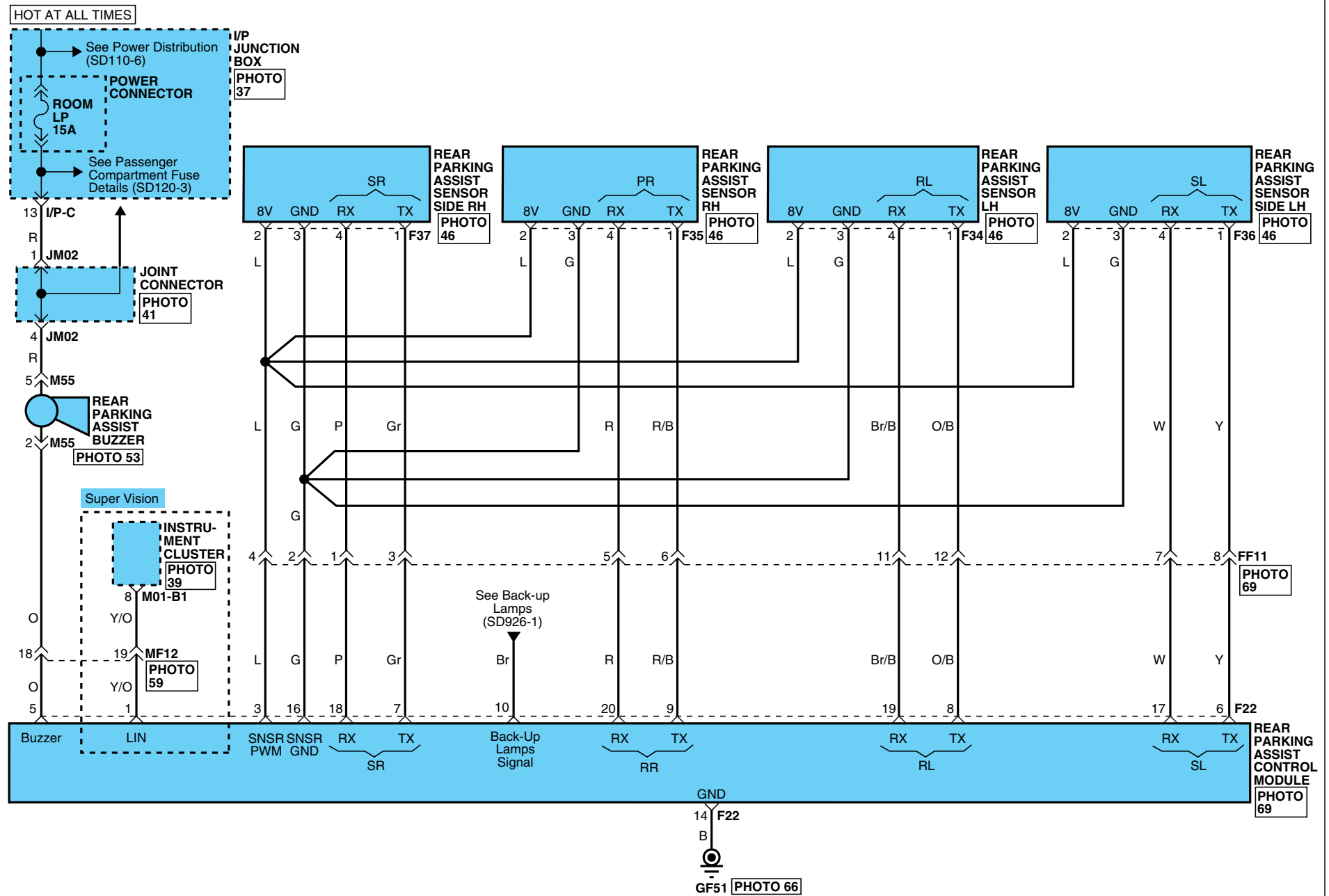

# REAR PARKING ASSIST SYSTEM

## Rear Parking Assist System (2)

SD957-2

**F22**

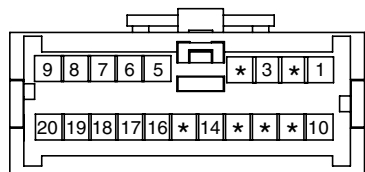

KUM\_040H1\_20F\_W

**F34**

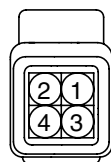

MLX\_060WP\_04F\_B

**F35**



MLX\_060WP\_04F\_B

**F36**

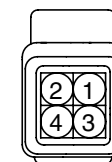

MLX\_060WP\_04F\_B

**F37**

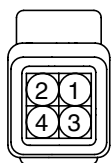

MLX\_060WP\_04F\_B

**M01-B1**

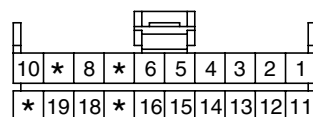

AMP\_040M1\_20F\_B

**M55**

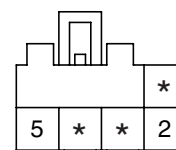

KUM\_CDR\_05F\_W

**BLANK**

Audio (1)

SD961-1

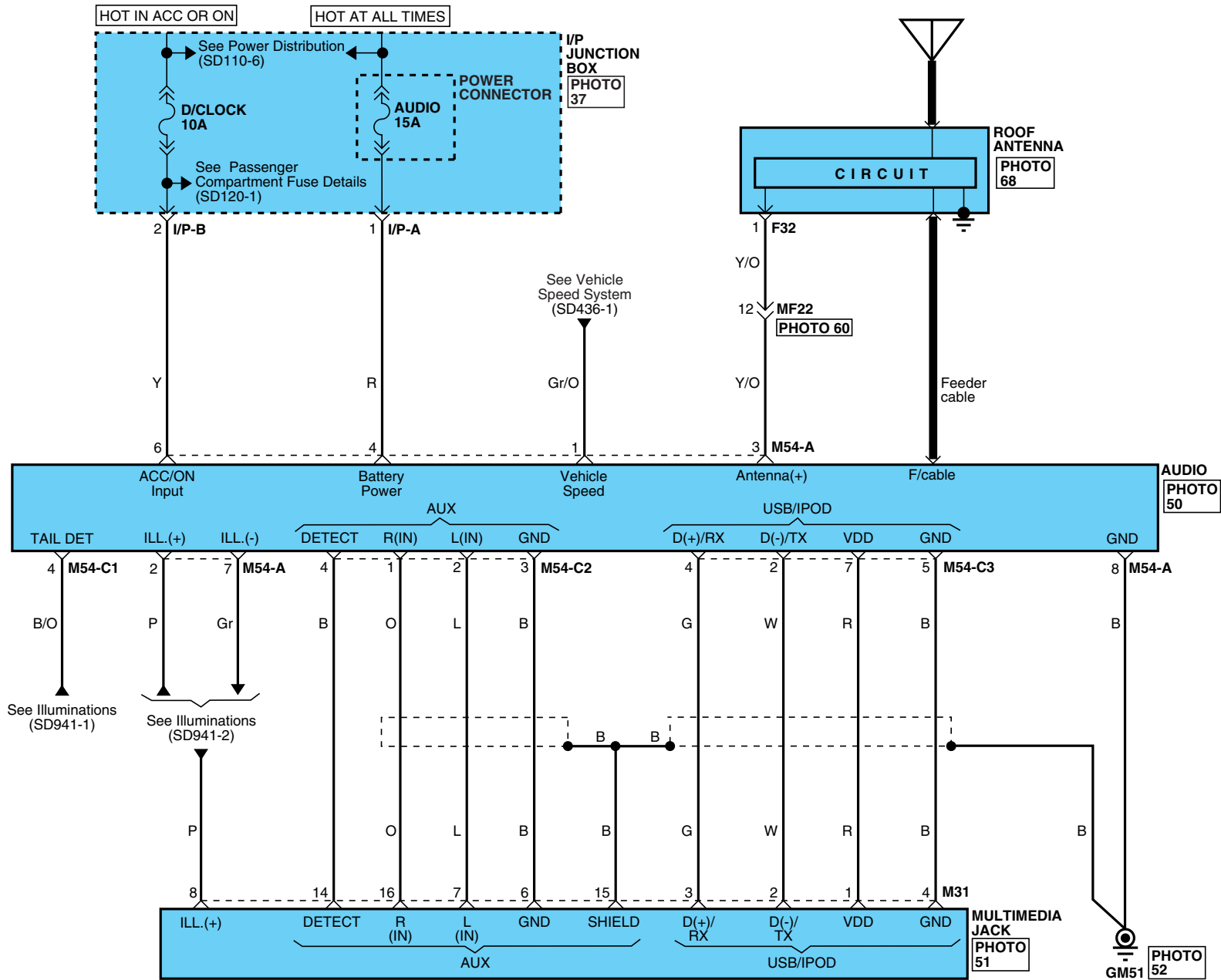





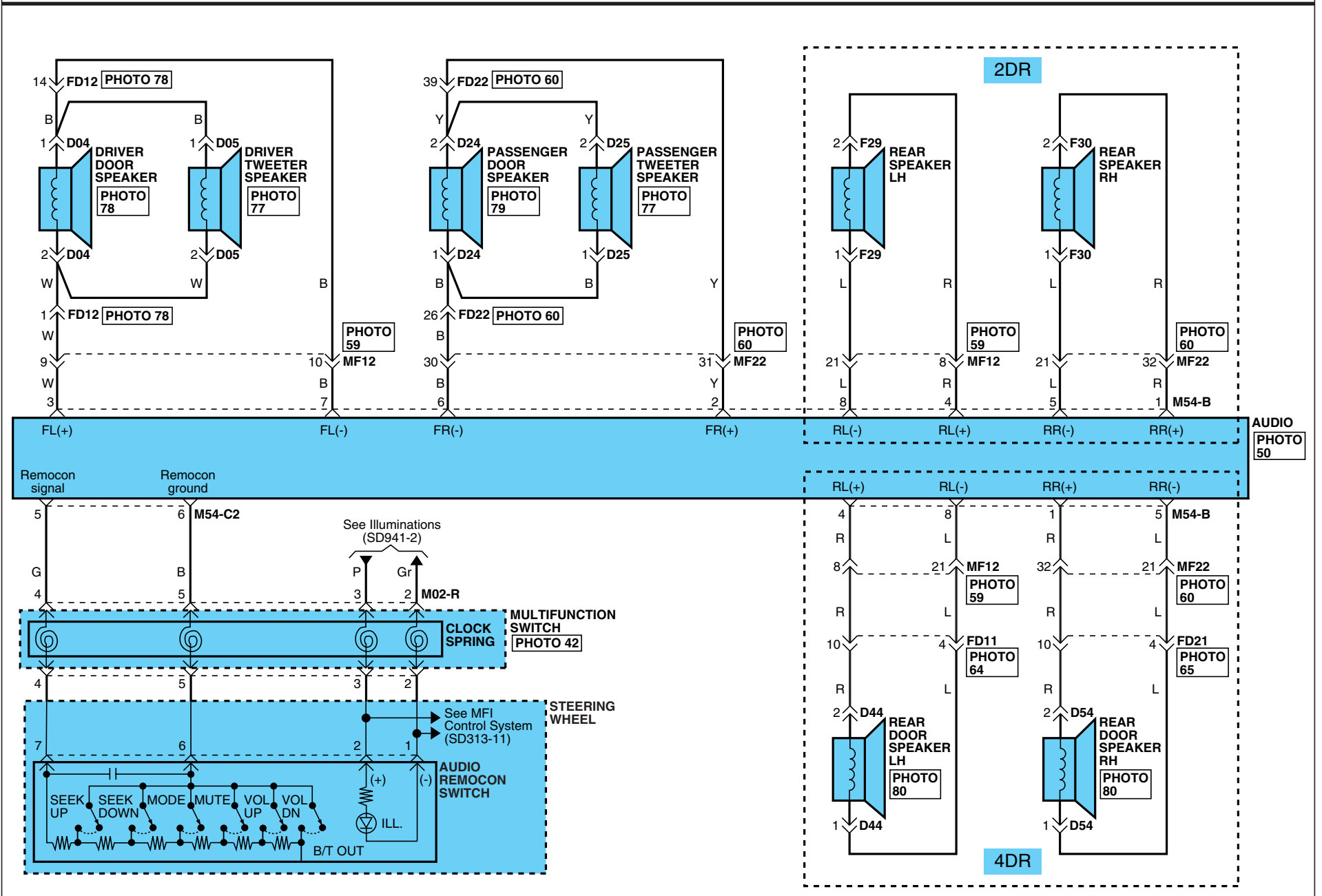

# AUDIO

## Audio (2)

SD961-2

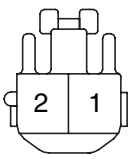
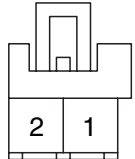
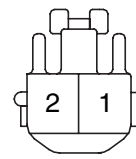
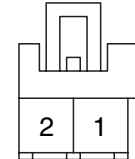
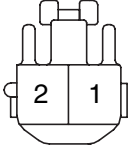
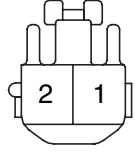
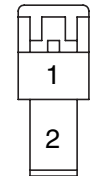
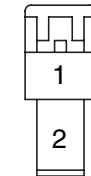

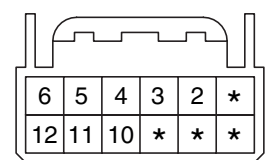
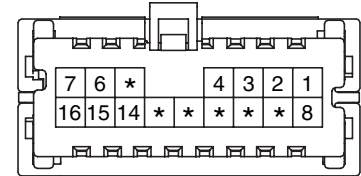
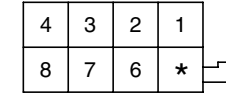
# AUDIO

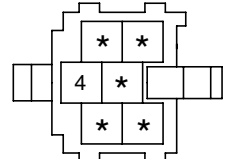
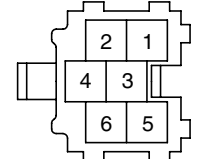
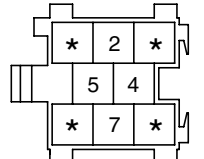
Audio (3)			SD961-3
<p><b>D04</b></p>  <p>KET_090III_02F_W_L</p>	<p><b>D05</b></p>  <p>KUM_CDR_02F_W</p>	<p><b>D24</b></p>  <p>KET_090III_02F_W_L</p>	<p><b>D25</b></p>  <p>KUM_CDR_02F_W</p>
<p><b>D44</b></p>  <p>KET_090III_02F_W_L</p>	<p><b>D54</b></p>  <p>KET_090III_02F_W_L</p>	<p><b>F29</b></p>  <p>KUM_DSD_02F_W</p>	<p><b>F30</b></p>  <p>KUM_DSD_02F_W</p>
<p><b>F32</b></p>  <p>KET_090_01F_W</p>	<p><b>M02-R</b></p>  <p>AMP_025_12F_W</p>	<p><b>M31</b></p>  <p>KET_040III_16F_W</p>	<p><b>M54-A</b></p>  <p>AMP_AUDIO_08F_GR_D2</p>
<p><b>M54-B</b></p>  <p>AMP_AUDIO_08F_GR_D1</p>	<p><b>M54-C1</b></p>  <p>AMP_AUDIO_06F_Y_C1</p>	<p><b>M54-C2</b></p>  <p>AMP_AUDIO_06F_G_C2</p>	<p><b>M54-C3</b></p>  <p>AMP_AUDIO_08F_L_C3</p>

**AUDIO**

Audio (4)

SD961-4

MEMO

Horn (1)

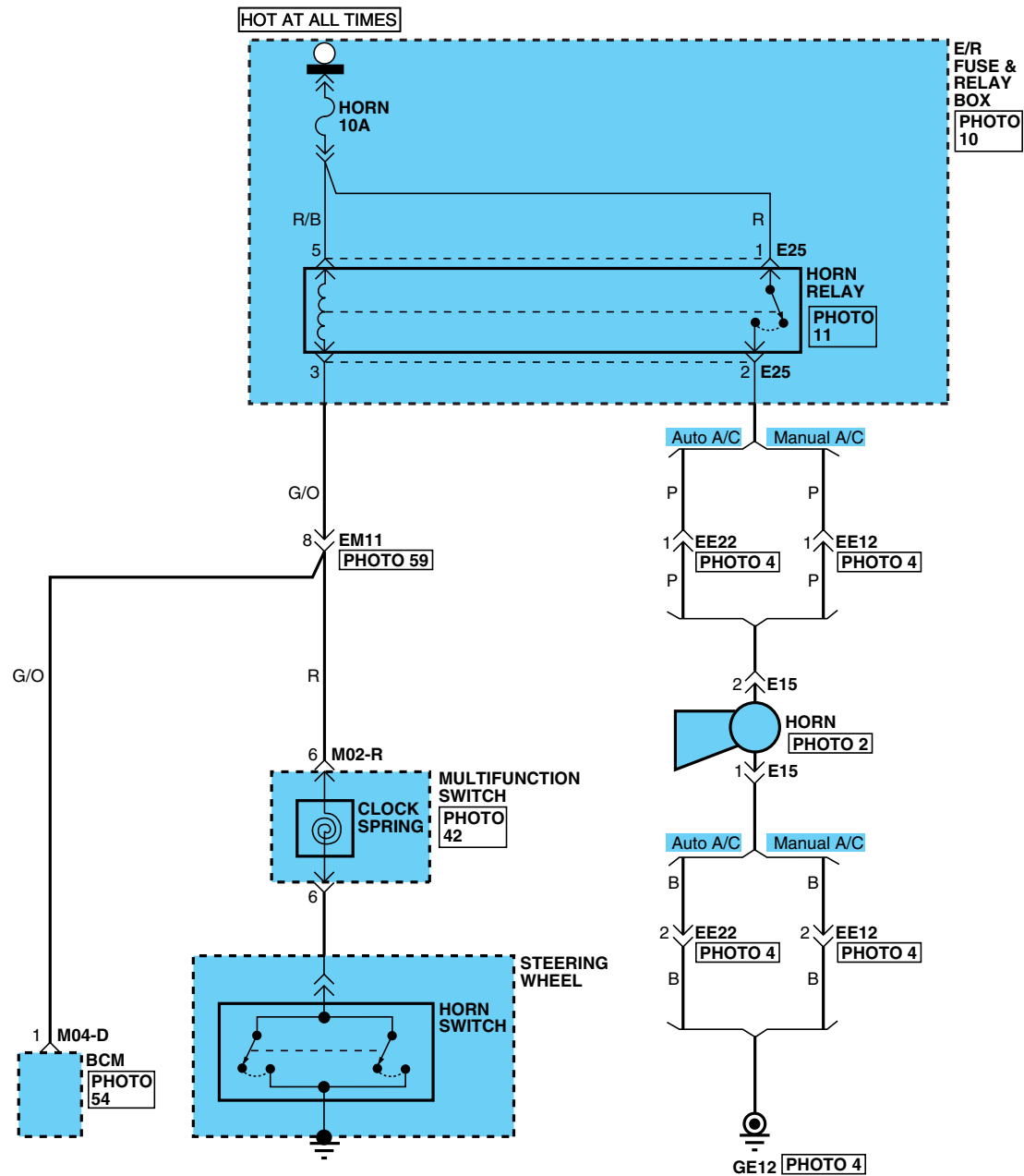

# HORN

Horn (2)

SD968-2

E15

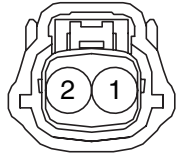

MLX\_HORN\_02F\_B\_FILT

E25

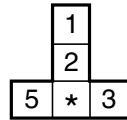

CR05F011

M02-R

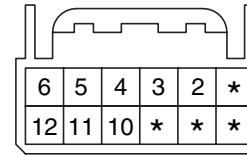

AMP\_025\_12F\_W

M04-D

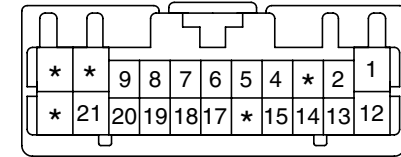

KET\_0407\_22F\_W

# BLOWER & A/C CONTROL SYSTEM

E5D56C81

## Blower & A/C Control System (Auto) (1)

SD971-1

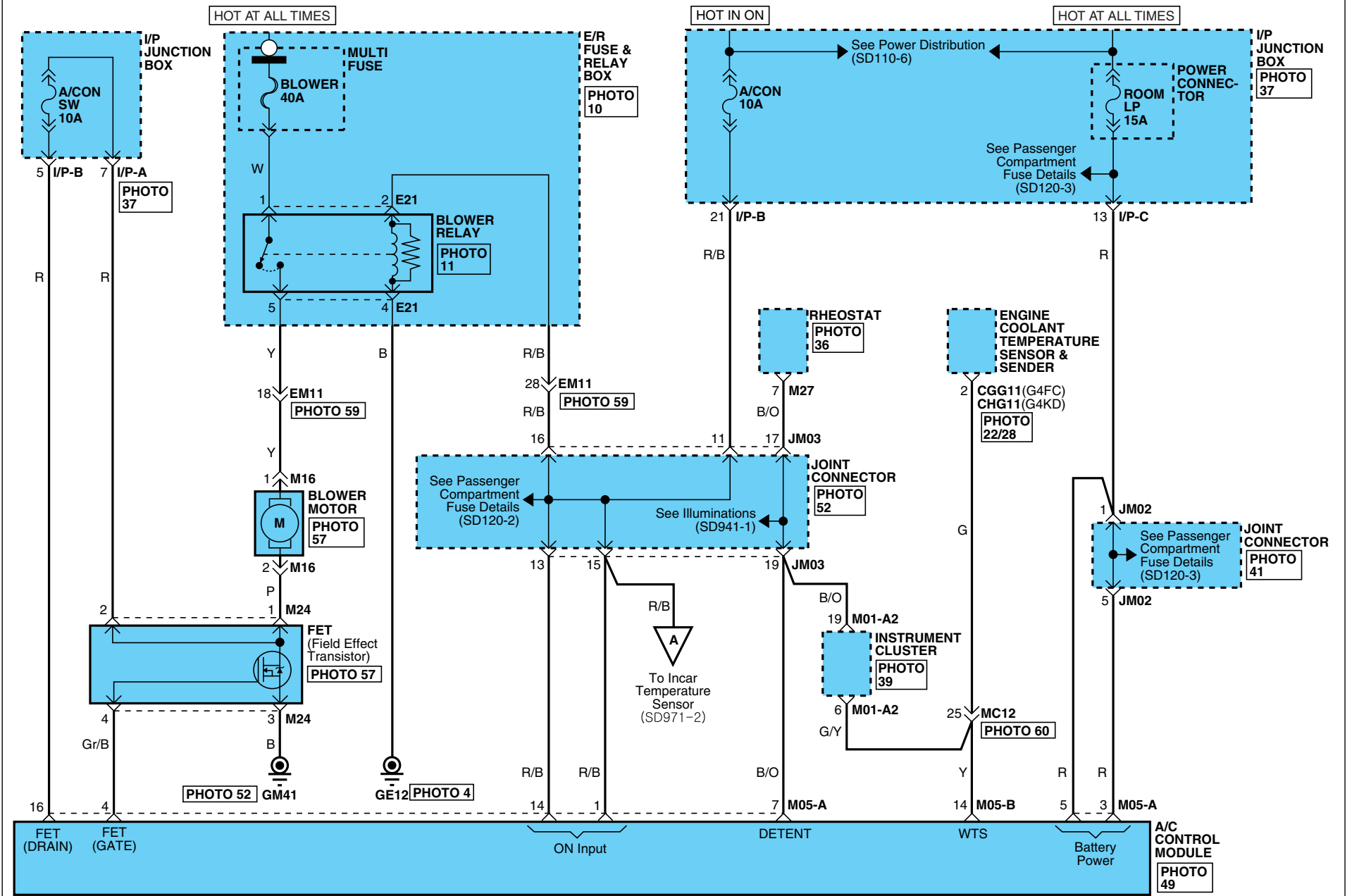

# BLOWER & A/C CONTROL SYSTEM

## Blower & A/C Control System (Auto) (2)

SD971-2

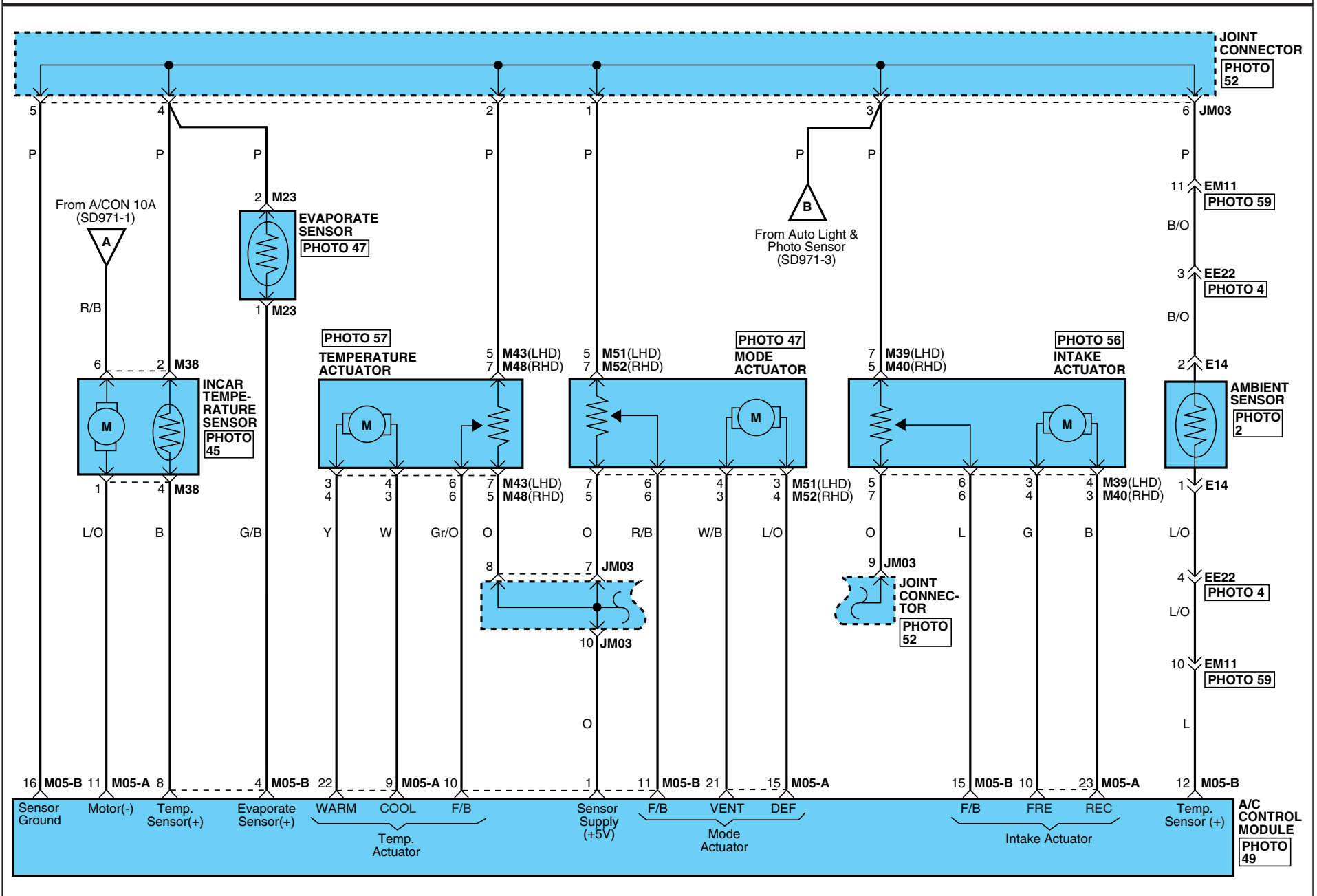

# BLOWER & A/C CONTROL SYSTEM

## Blower & A/C Control System (Auto) (3)

SD971-3

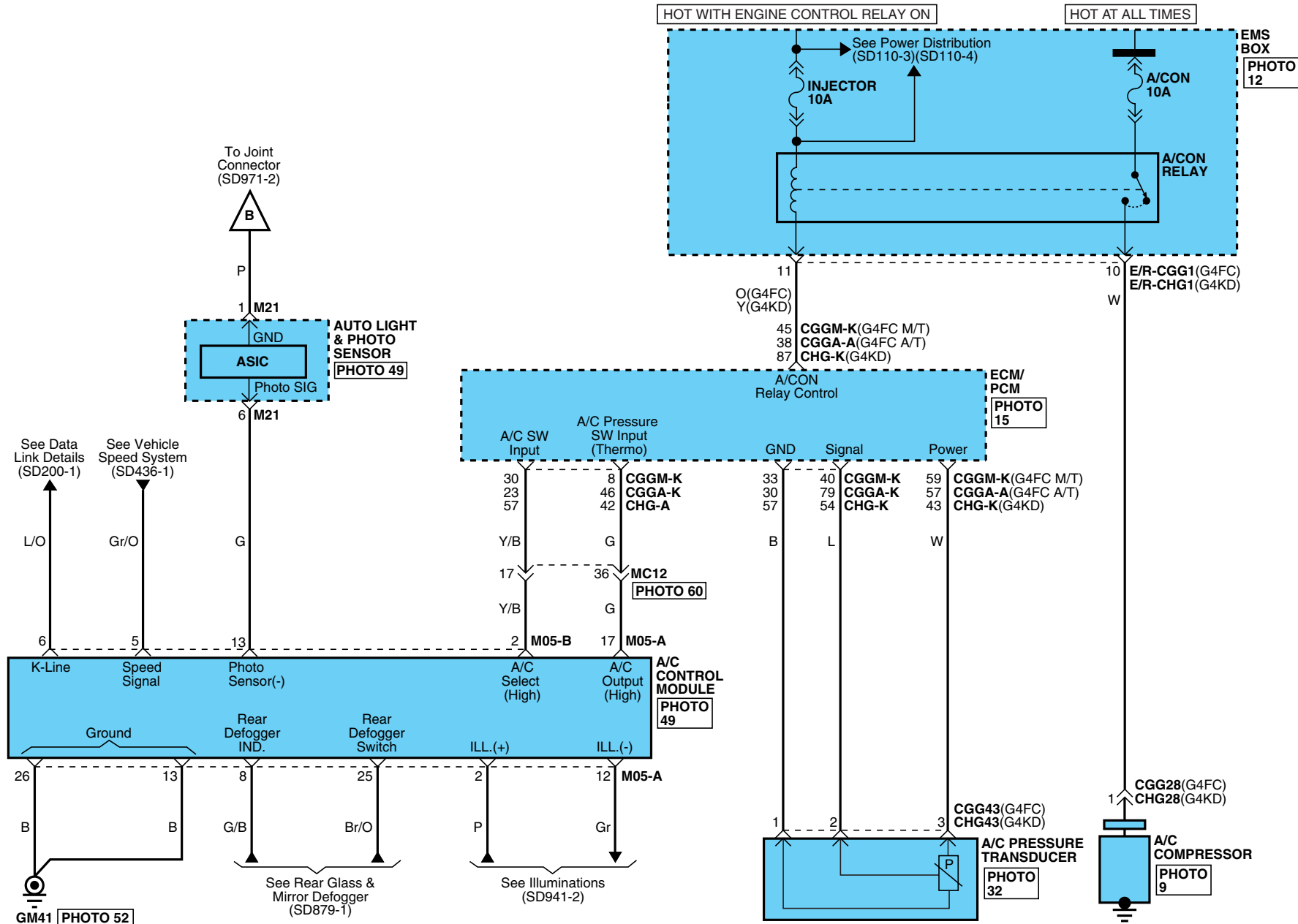



# BLOWER & A/C CONTROL SYSTEM

## Blower & A/C Control System (Auto) (4)

SD971-4

**CGGA-A**

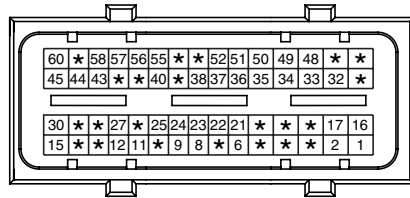

AMP\_ECU\_60F\_B

**CGGA-K**

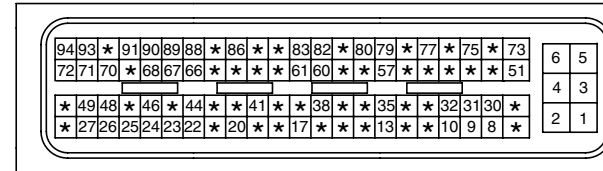

AMP\_ECU\_94F\_B

**CGGM-K**

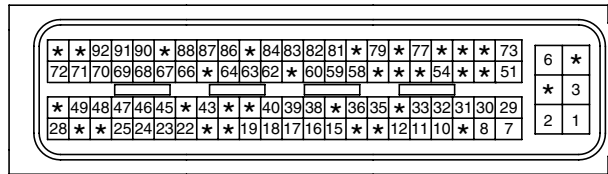

AMP\_ECU\_94F\_B

**CGG11**

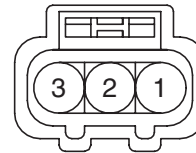

KUM\_62Z\_03F\_B\_WTS

**CGG28**



KUM\_NMWP\_01F\_B

**CGG43**

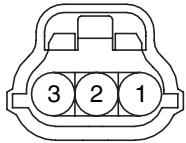

KET\_040WP\_03F\_B

**CHG-A**

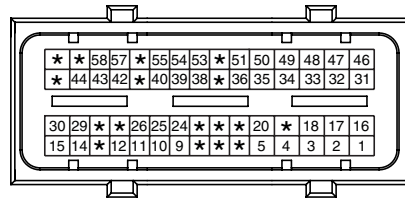

AMP\_ECU\_60F\_B\_A

**BLANK**

**CHG-K**

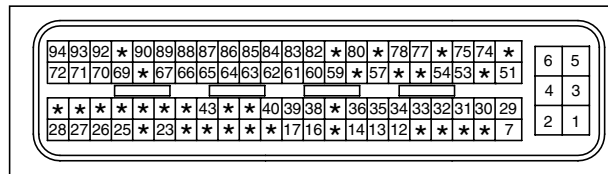

AMP\_ECU\_94F\_B

**CHG11**

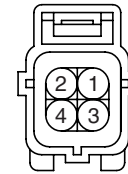

AMP\_EJWP\_04F\_B

**CHG28**



KUM\_NMWP\_01F\_B

**CHG43**

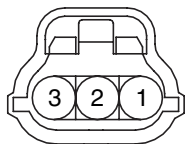

KET\_040WP\_03F\_B

**E14**

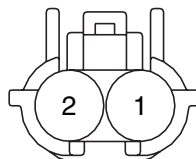

KET\_SWP\_02F\_B

**E21**

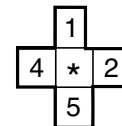

CR05F012

**M01-A2**

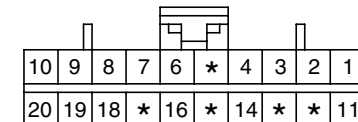

AMP\_040M2\_20F\_B

# BLOWER & A/C CONTROL SYSTEM

## Blower & A/C Control System (Auto) (5)

SD971-5

<p><b>M05-A</b></p> <p>KET_0407_26F_W</p>	<p><b>M05-B</b></p> <p>KET_0407_16F_W</p>	<p><b>M16</b></p> <p>KUM_DSD_02F_B</p>	<p><b>M21</b></p> <p>KET_91A_06F_GR_1</p>
<p><b>M23</b></p> <p>AMP_070_02F_B</p>	<p><b>M24</b></p> <p>KUM_DSD_04F_B</p>	<p><b>M27</b></p> <p>KUM_CDR_07F_B</p>	<p><b>M38</b></p> <p>KET_91A_06F_W</p>
<p><b>M39</b></p> <p>KUM_CDR_07F_W</p>	<p><b>M40</b></p> <p>KUM_CDR_07F_W</p>	<p><b>M43</b></p> <p>KUM_CDR_07F_W</p>	<p><b>M48</b></p> <p>KUM_CDR_07F_W</p>
<p><b>M51</b></p> <p>KUM_CDR_07F_W</p>	<p><b>M52</b></p> <p>KUM_CDR_07F_W</p>	<p><b>BLANK</b></p>	<p><b>BLANK</b></p>

**BLOWER & A/C CONTROL SYSTEM**

**Blower & A/C Control System (Auto) (6)**

**SD971-6**

**MEMO**

Blower & A/C Control System (Manual) (1)

SD971-7

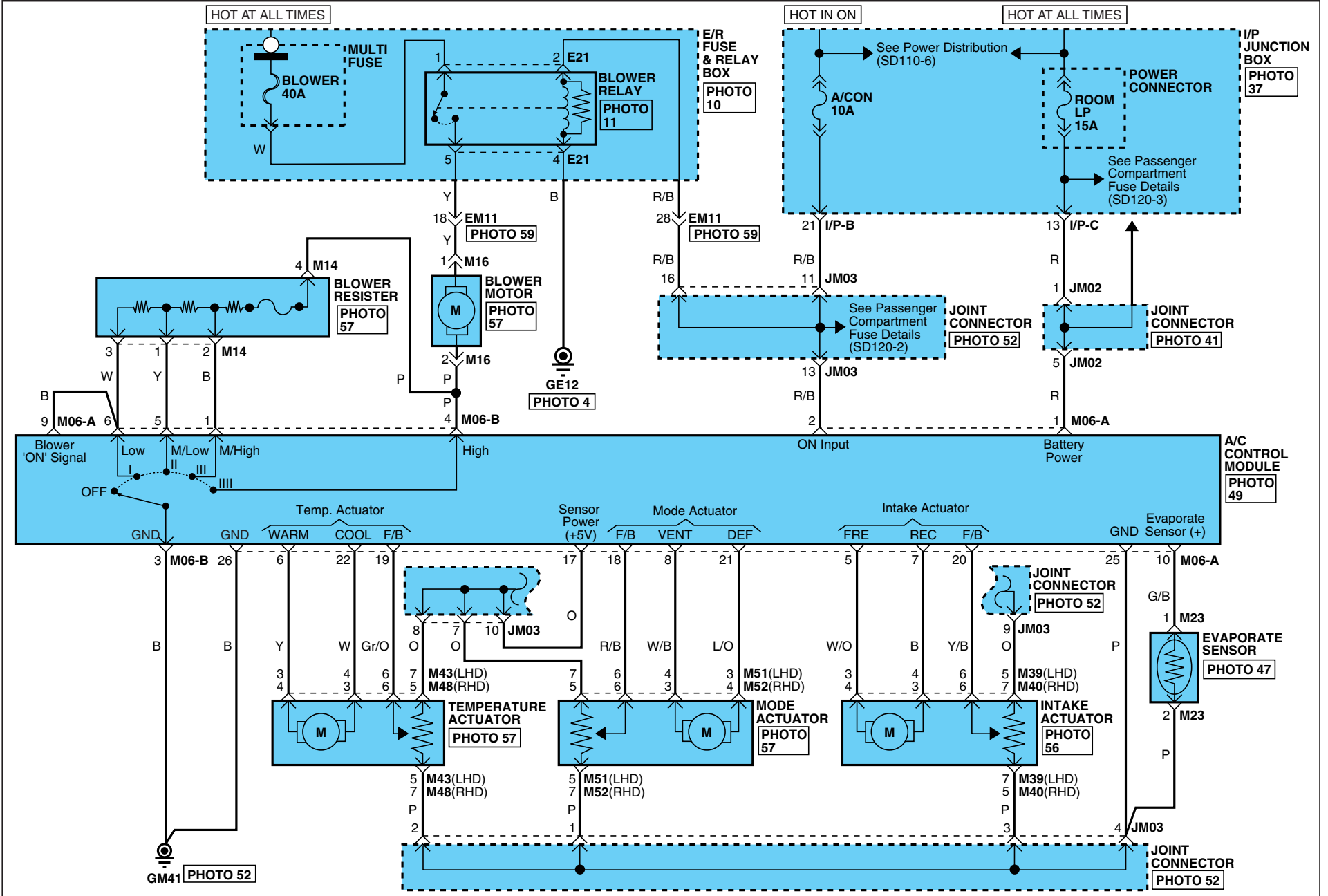

# BLOWER & A/C CONTROL SYSTEM

## Blower & A/C Control System (Manual) (2)

SD971-8

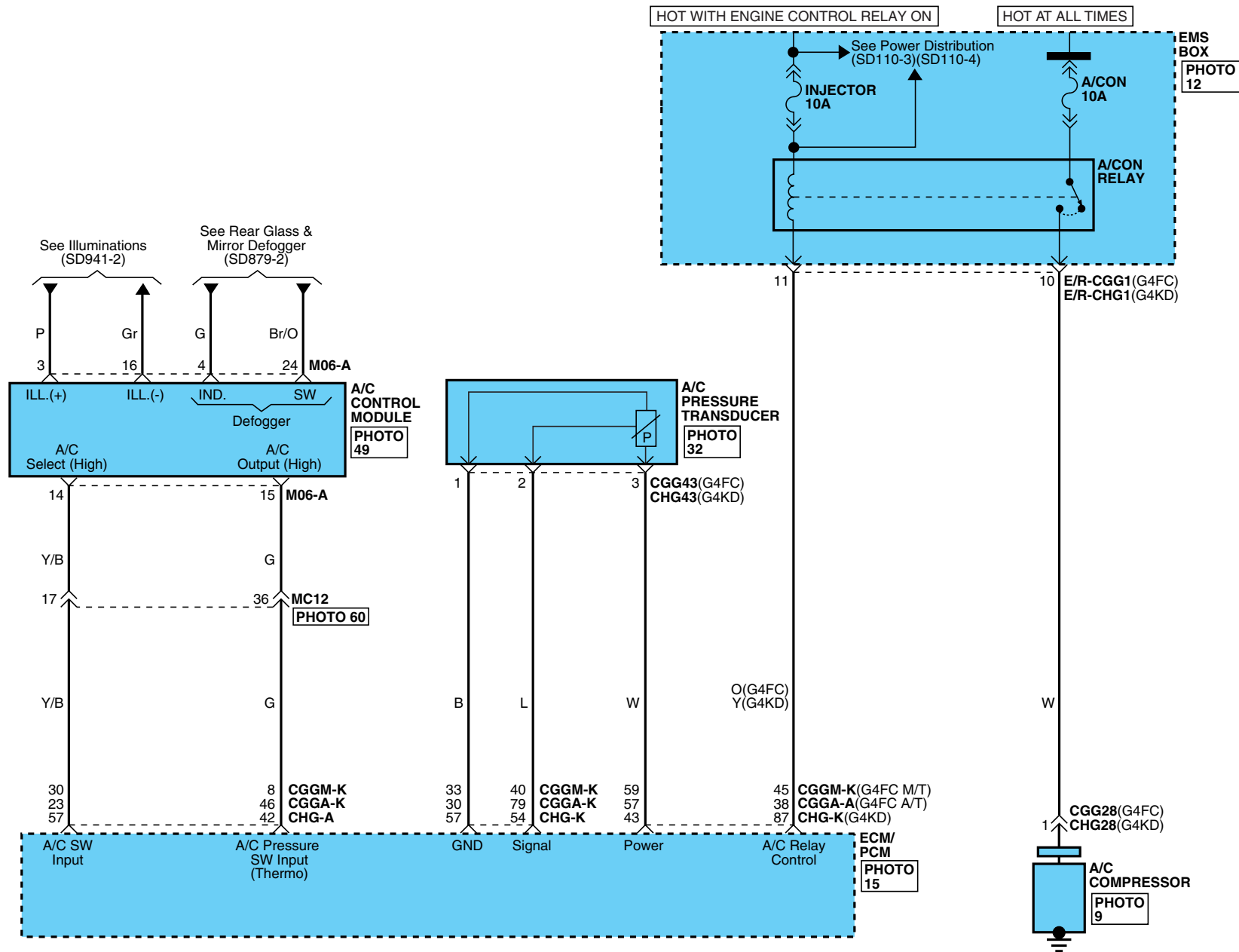

# BLOWER & A/C CONTROL SYSTEM

## Blower & A/C Control System (Manual) (3)

SD971-9

**CGGA-A**

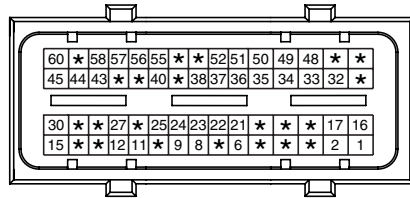

AMP\_ECU\_60F\_B

**CGGA-K**

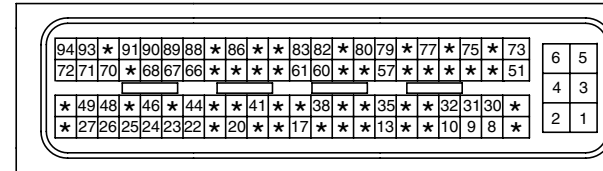

AMP\_ECU\_94F\_B

**CGGM-K**

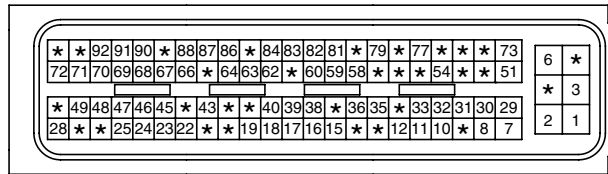

AMP\_ECU\_94F\_B

**CGG28**



KUM\_NMWP\_01F\_B

**CGG43**

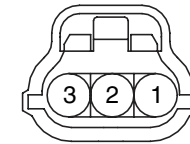

KET\_040WP\_03F\_B

**CHG-A**

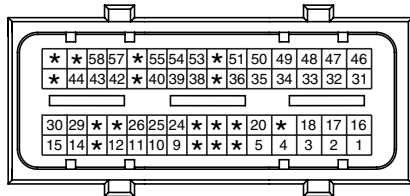

AMP\_ECU\_60F\_B\_A

**CHG-K**

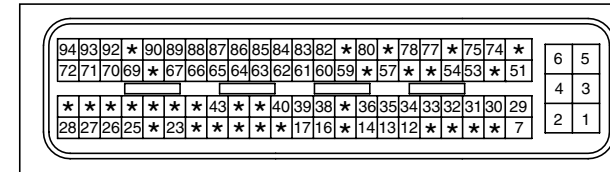

AMP\_ECU\_94F\_B

**CHG28**



KUM\_NMWP\_01F\_B

**CHG43**

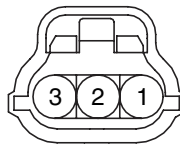

KET\_040WP\_03F\_B

**E21**

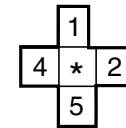

CR05F012

**M06-A**

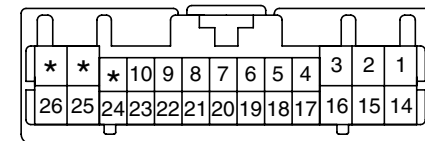

KET\_0407\_26F\_W

**M06-B**

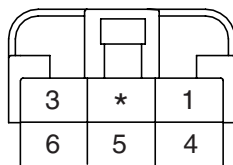

KET\_250DL\_06F\_W

**M14**

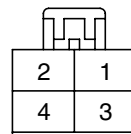

KUM\_DSD\_04F\_B

**M16**

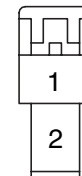

KUM\_DSD\_02F\_B

**M23**

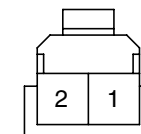

AMP\_070\_02F\_B

# BLOWER & A/C CONTROL SYSTEM

## Blower & A/C Control System (Manual) (4)

SD971-10

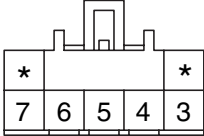
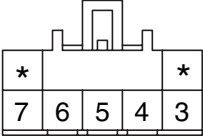
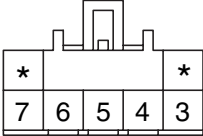
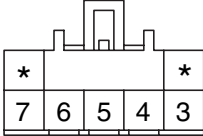
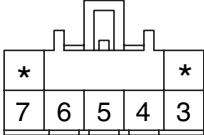
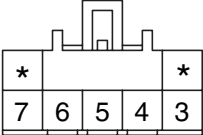
<p style="text-align: center;"><b>M39</b></p>  <p style="text-align: center;">KUM_CDR_07F_W</p>	<p style="text-align: center;"><b>M40</b></p>  <p style="text-align: center;">KUM_CDR_07F_W</p>	<p style="text-align: center;"><b>M43</b></p>  <p style="text-align: center;">KUM_CDR_07F_W</p>	<p style="text-align: center;"><b>M48</b></p>  <p style="text-align: center;">KUM_CDR_07F_W</p>
<p style="text-align: center;"><b>M51</b></p>  <p style="text-align: center;">KUM_CDR_07F_W</p>	<p style="text-align: center;"><b>M52</b></p>  <p style="text-align: center;">KUM_CDR_07F_W</p>	<p><b>BLANK</b></p>	<p><b>BLANK</b></p>

Front Wiper & Washer (1)

SD981-1

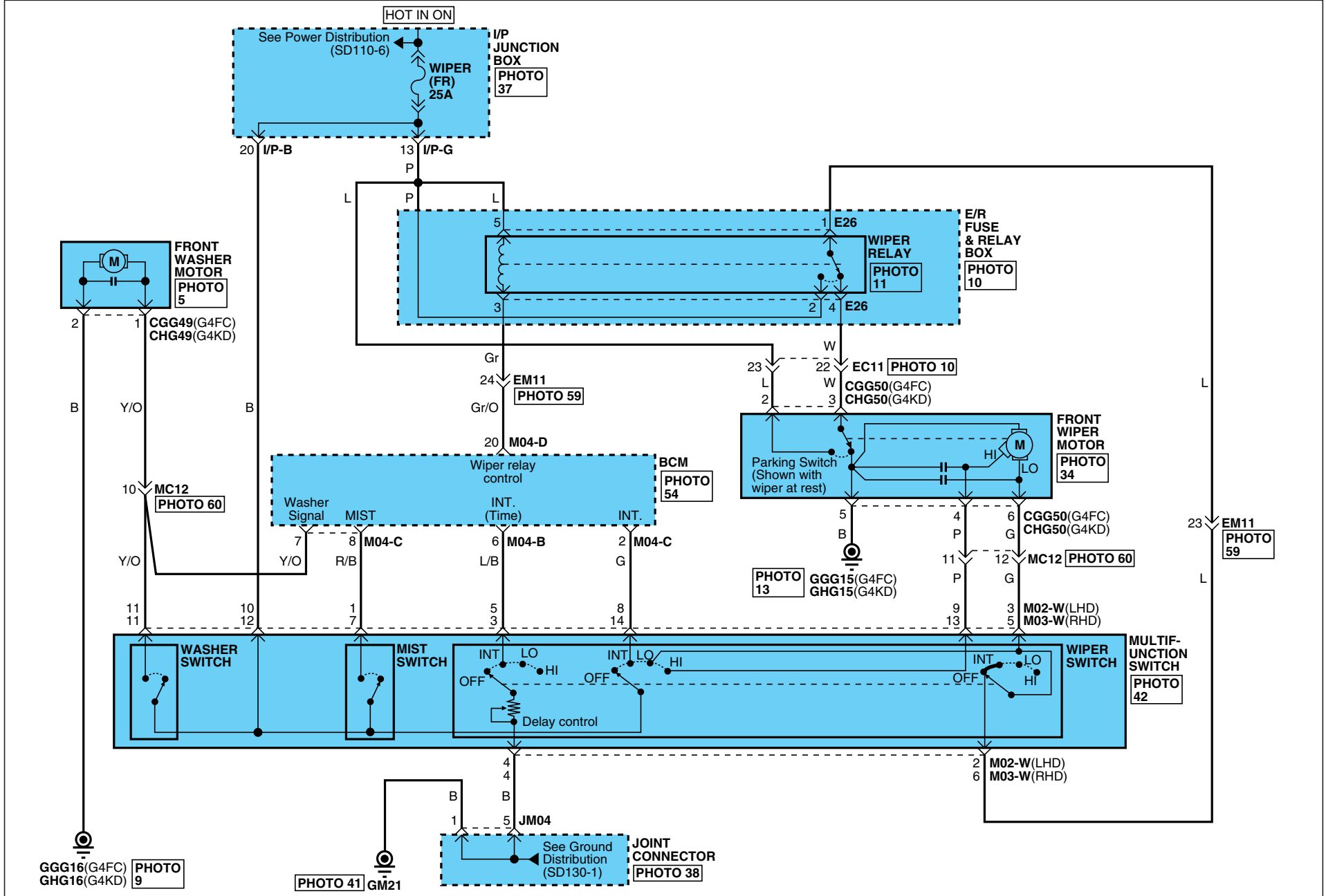



# FRONT WIPER & WASHER

## Front Wiper & Washer (2)

SD981-2

**CGG49**



KET\_090IWP\_03F\_B

**CGG50**

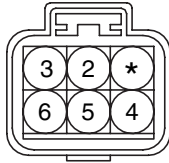

KUM\_NMWP\_06F\_B

**CHG49**



KET\_090IWP\_03F\_B

**CHG50**

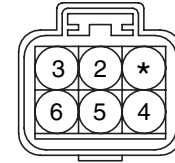

KUM\_NMWP\_06F\_B

**E26**

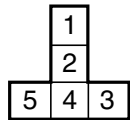

CR05F011

**M02-W**

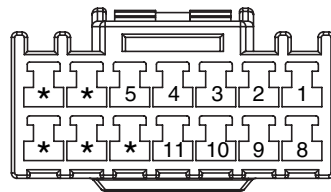

KET\_N090III\_14F\_W

**M03-W**

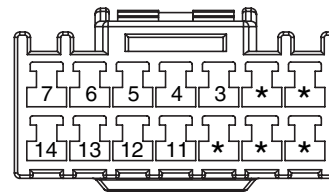

KET\_N090III\_14F\_W

**M04-B**

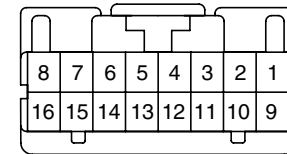

KET\_0407\_16F\_W

**M04-C**

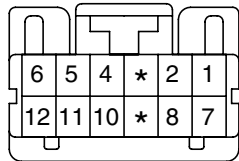

KET\_0407\_12F\_W

**M04-D**

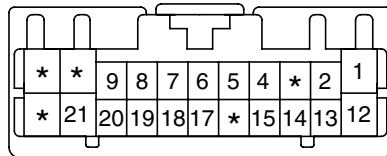

KET\_0407\_22F\_W

**BLANK**

**BLANK**

Component Locations (1)

CL-1

PHOTO.1

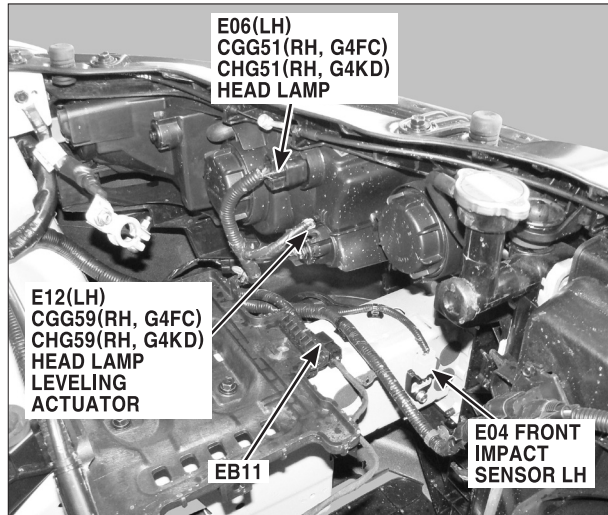

PHOTO.2

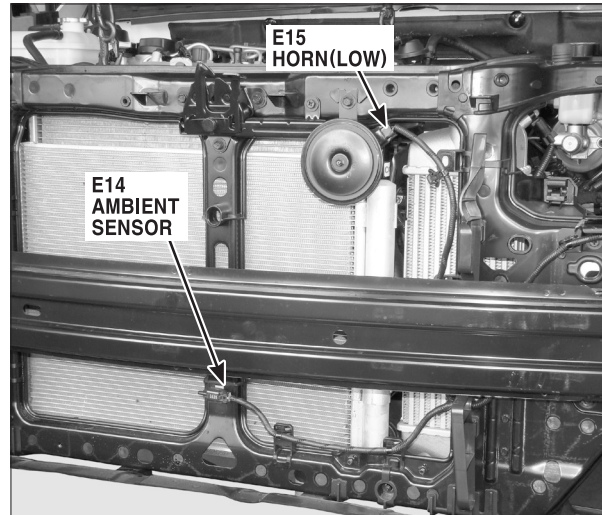

PHOTO.3

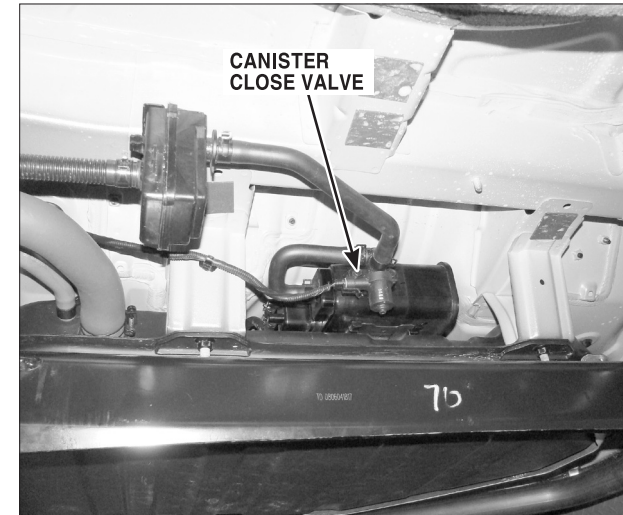

PHOTO.4

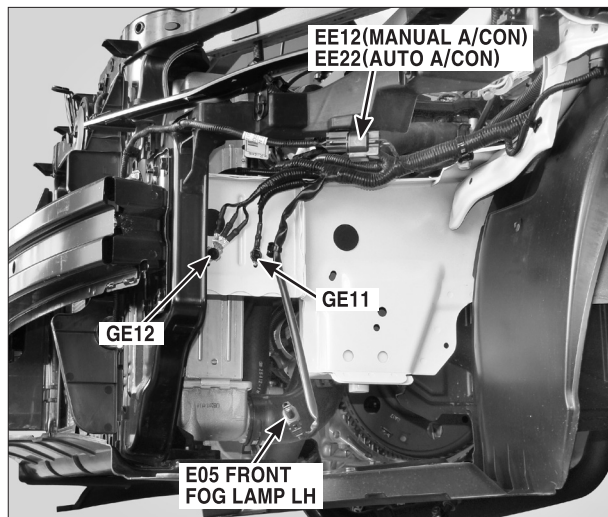

PHOTO.5

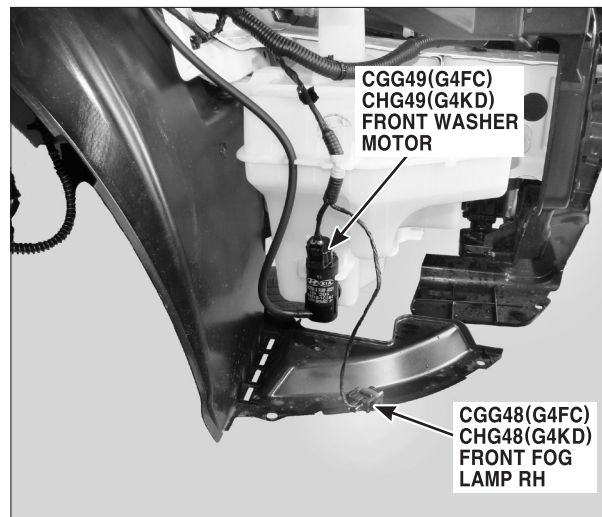
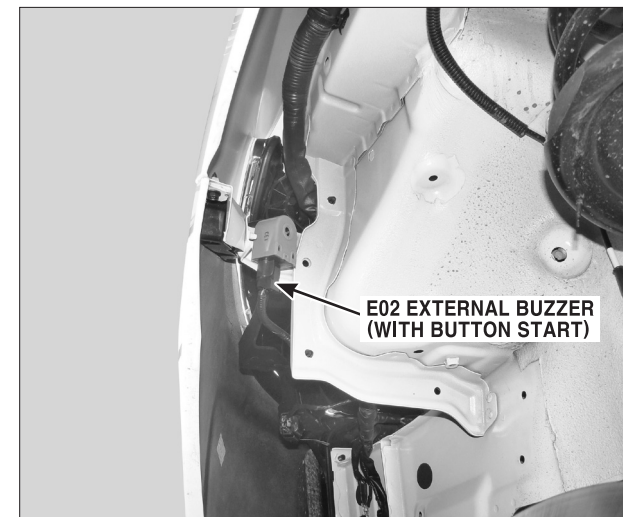

PHOTO.6



# COMPONENT LOCATIONS

## Component Locations (2)

CL-2

PHOTO.7

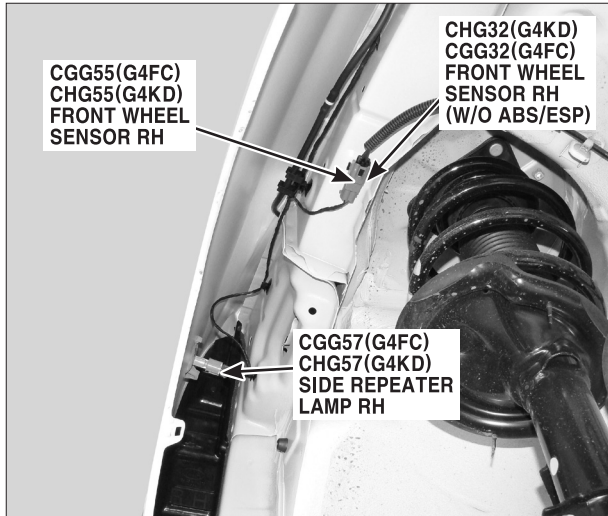

PHOTO.8

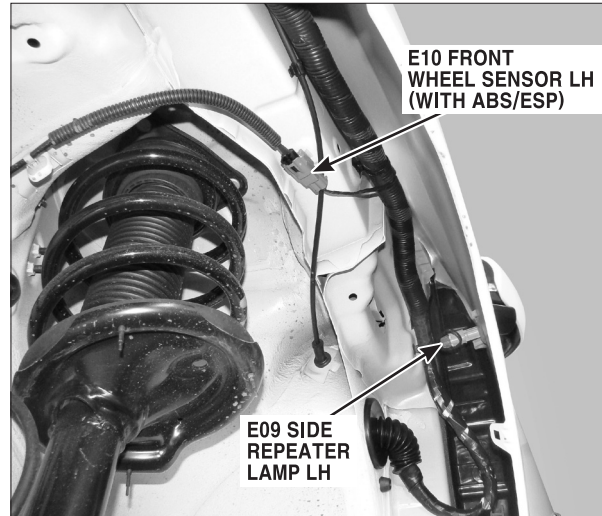

PHOTO.9

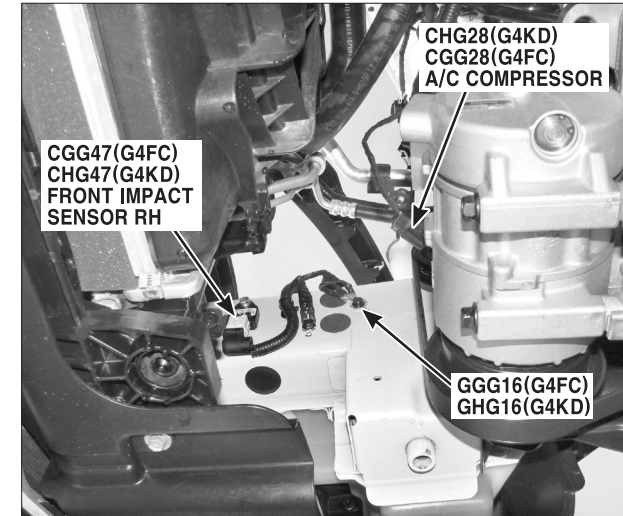

PHOTO.10

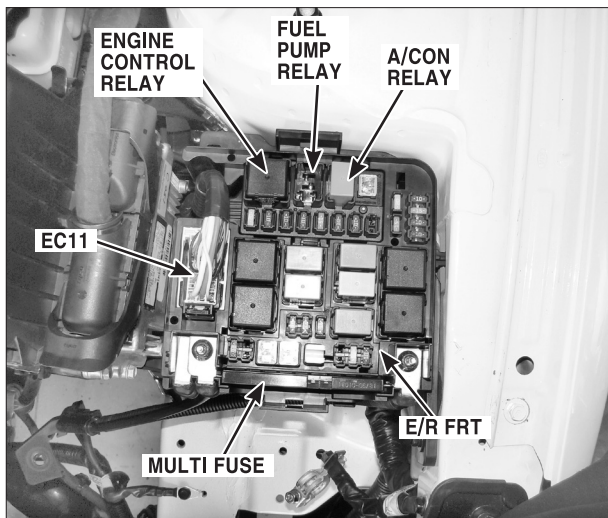

PHOTO.11

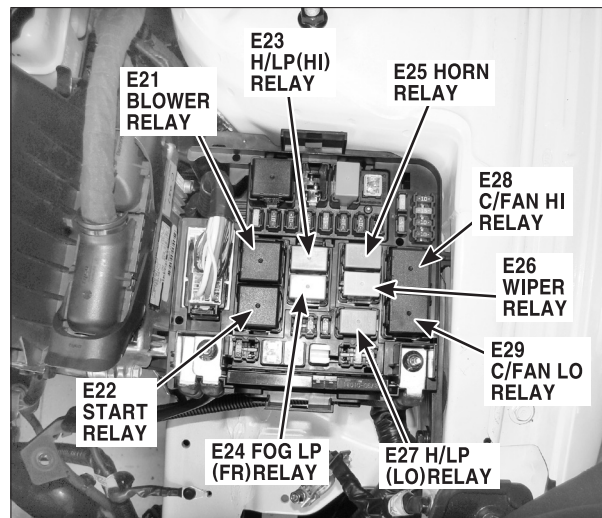
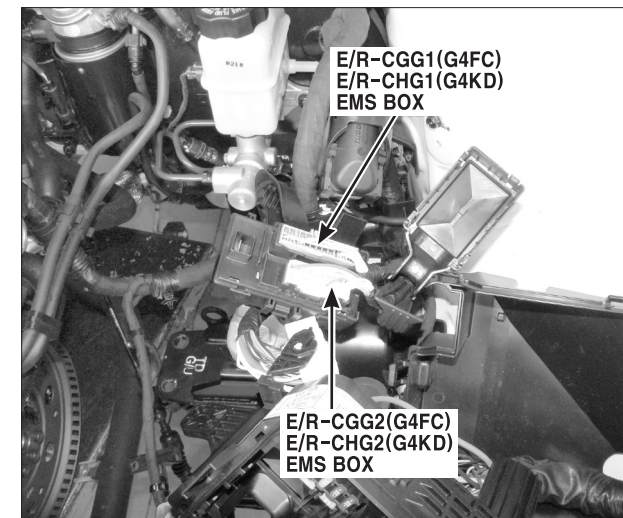

PHOTO.12



# COMPONENT LOCATIONS

## Component Locations (3)

CL-3

PHOTO.13

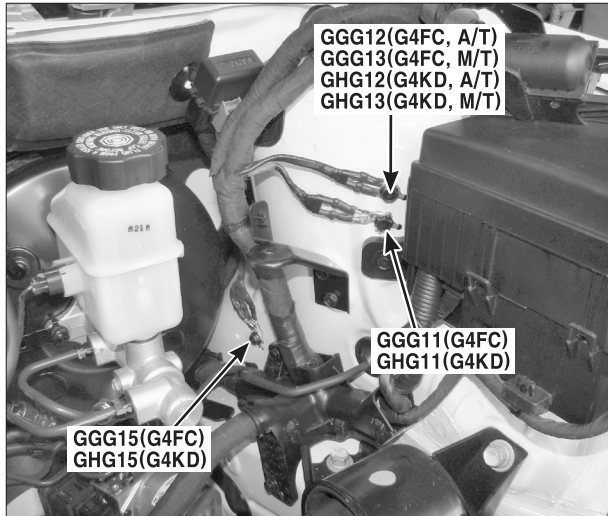

PHOTO.14

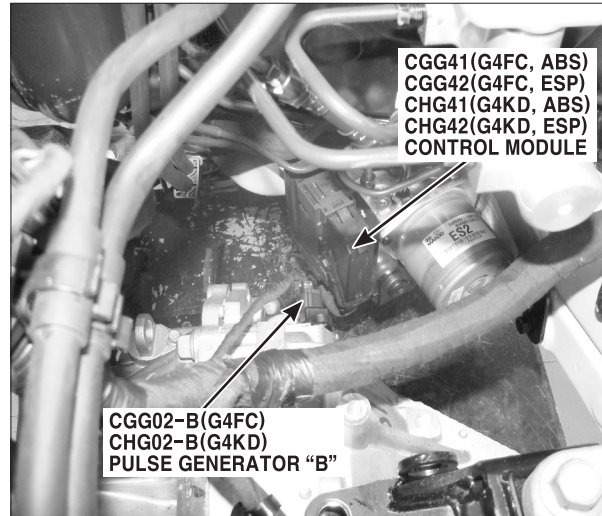

PHOTO.15

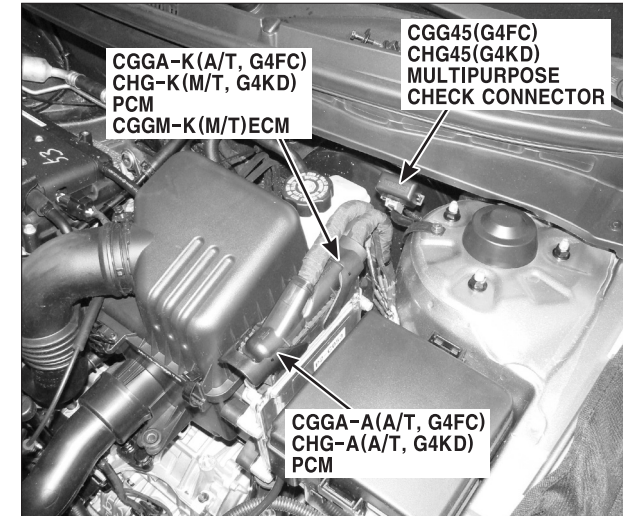

PHOTO.16



PHOTO.17

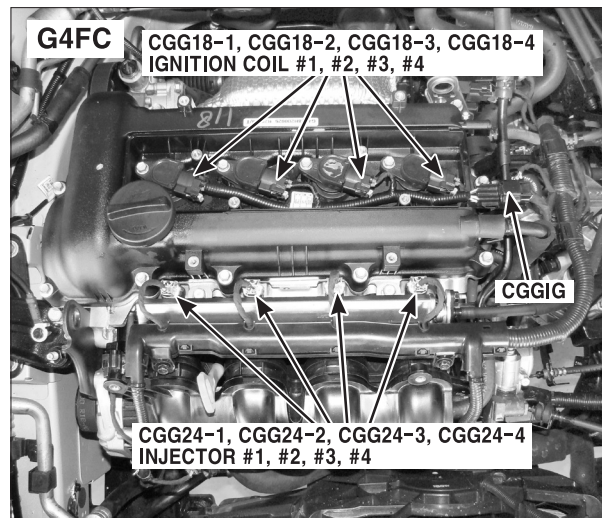
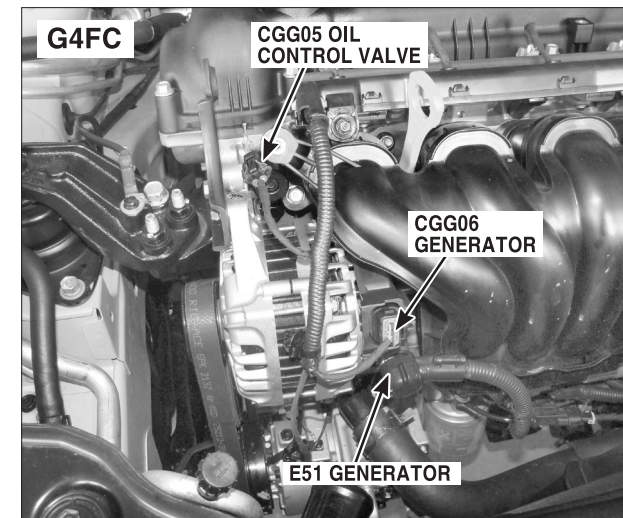

PHOTO.18



# COMPONENT LOCATIONS

## Component Locations (4)

CL-4

PHOTO.19

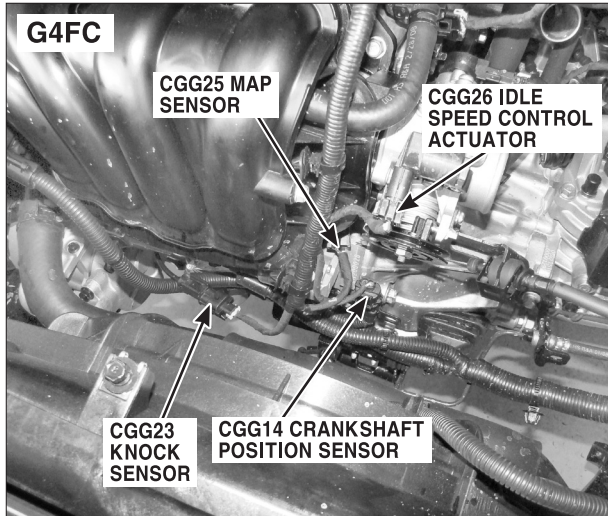

PHOTO.20

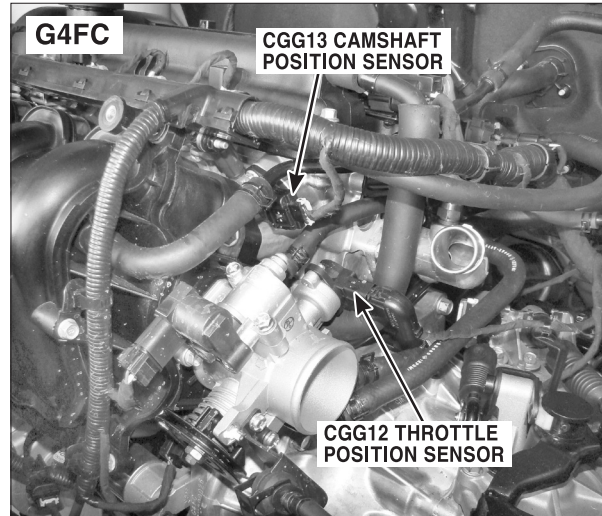

PHOTO.21

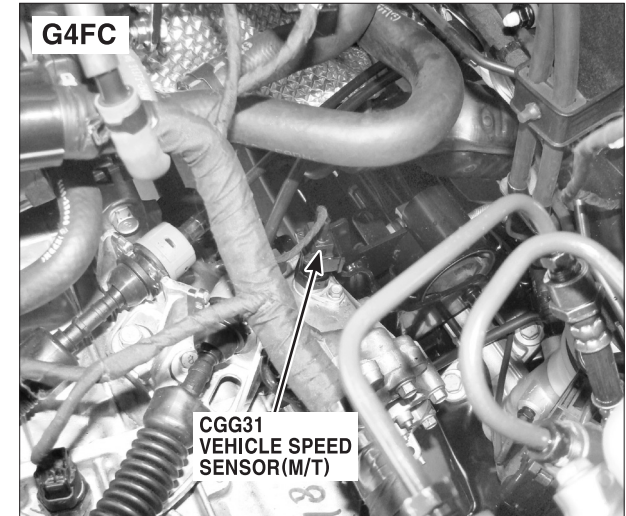

PHOTO.22

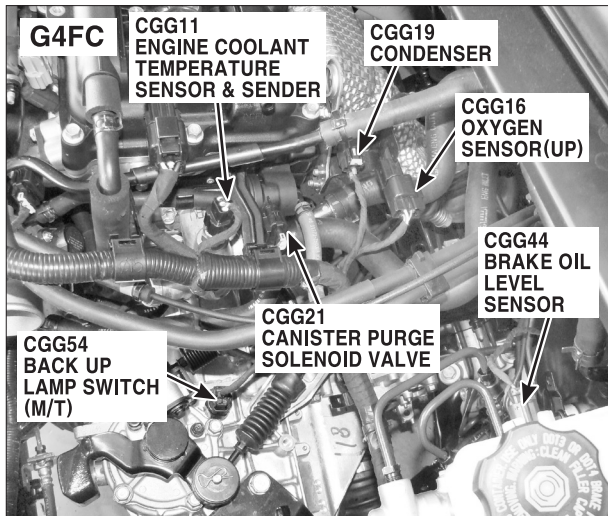

PHOTO.23

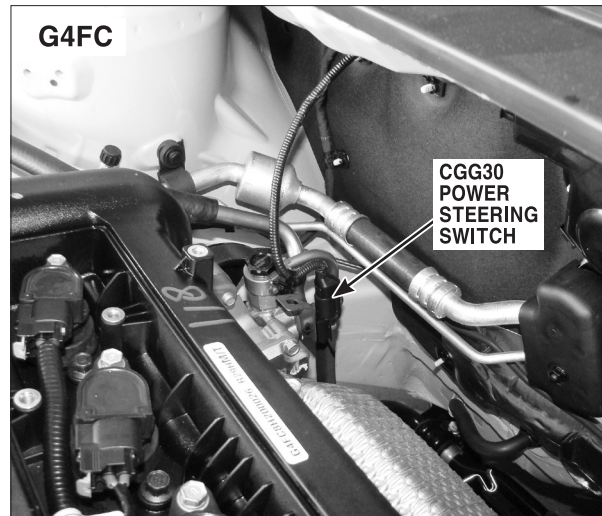
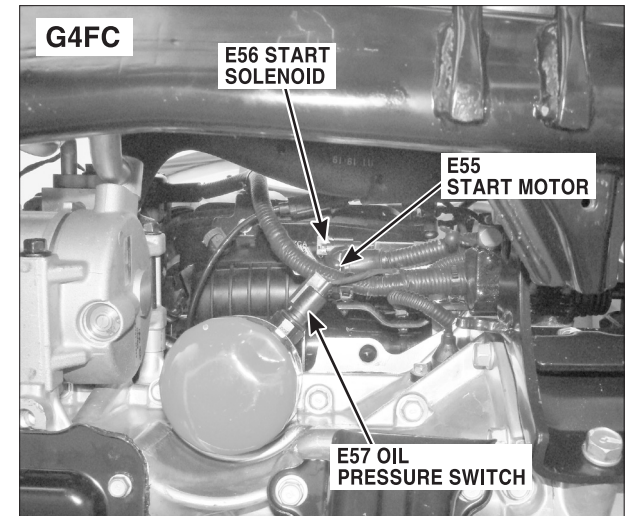

PHOTO.24



# COMPONENT LOCATIONS

## Component Locations (5)

CL-5

PHOTO.25

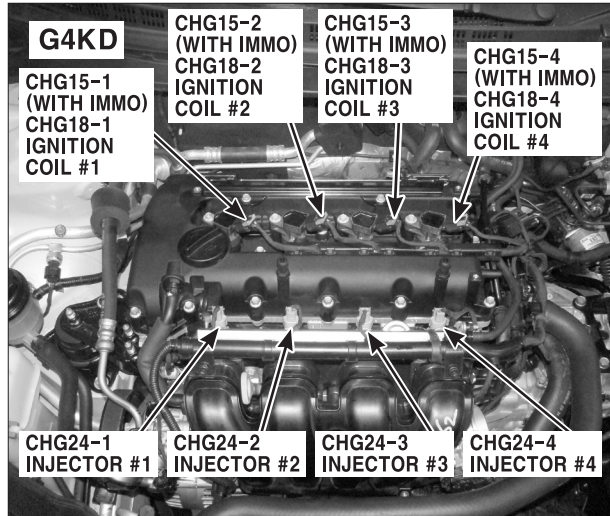

PHOTO.26

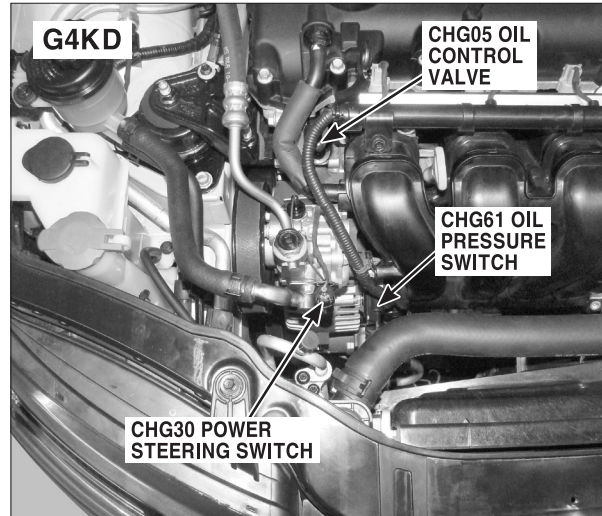

PHOTO.27

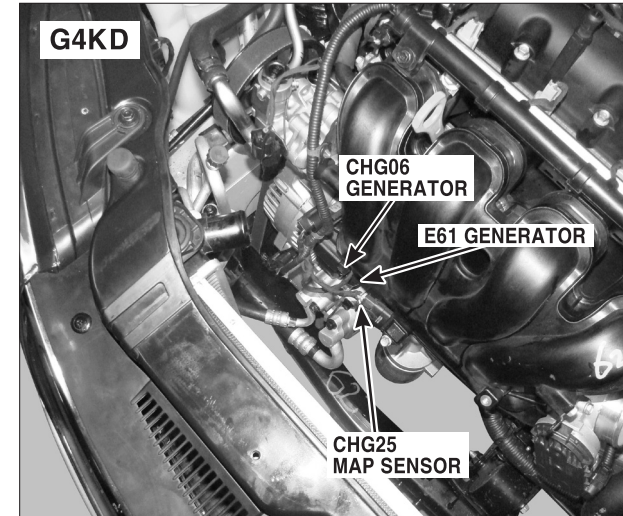

PHOTO.28

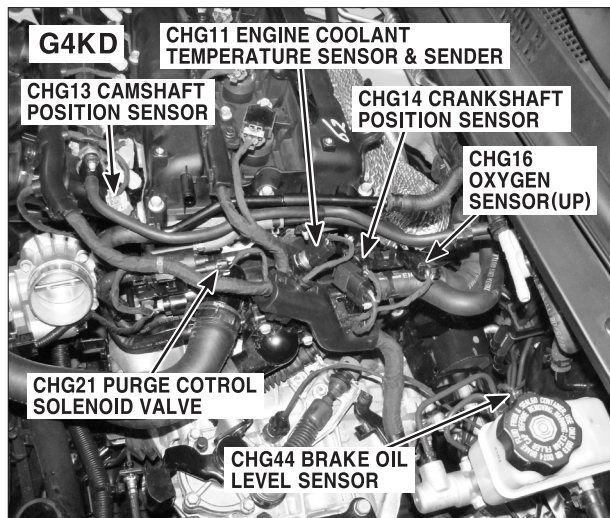
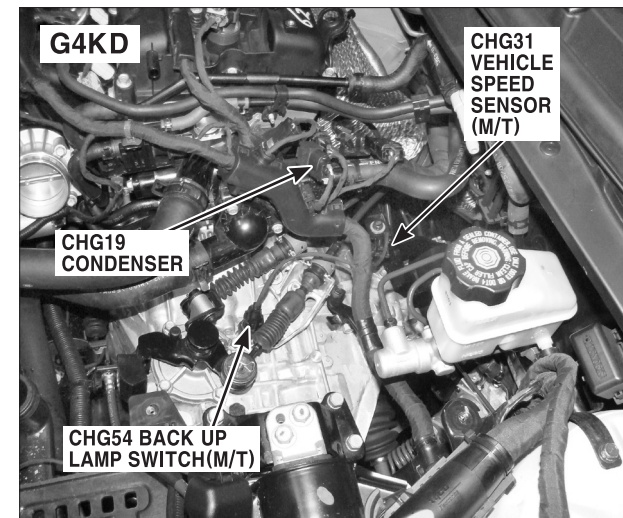

PHOTO.29



PHOTO.30



# COMPONENT LOCATIONS

## Component Locations (6)

CL-6

PHOTO.31

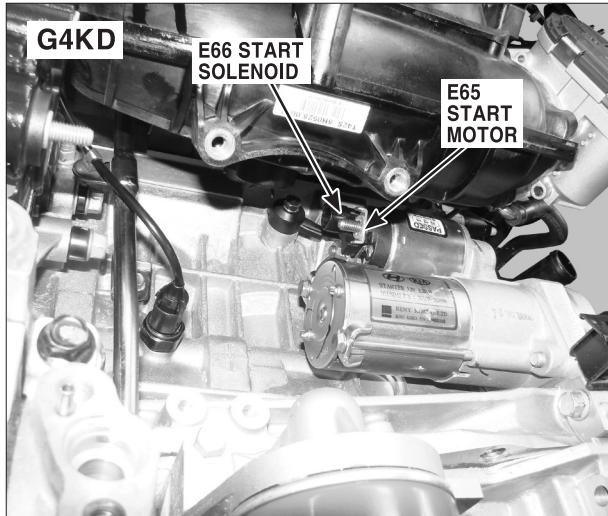

PHOTO.32



PHOTO.33

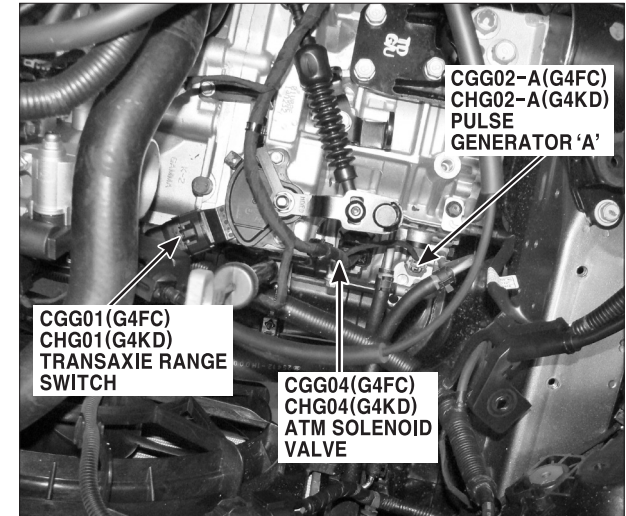

PHOTO.34

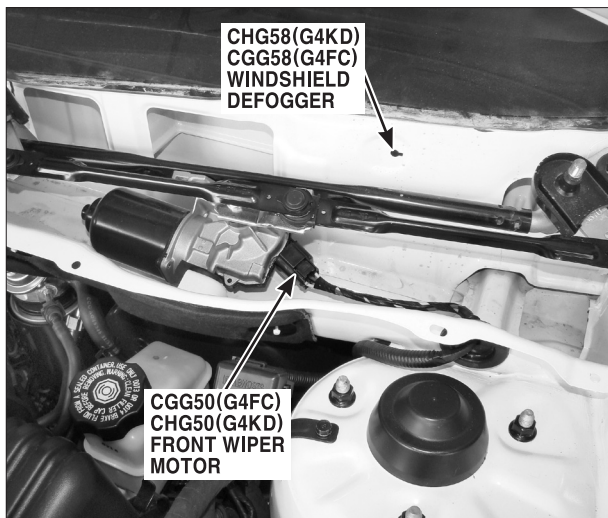

PHOTO.35

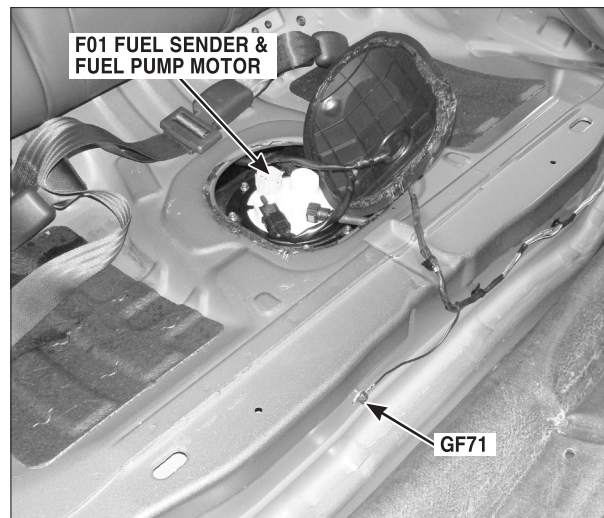
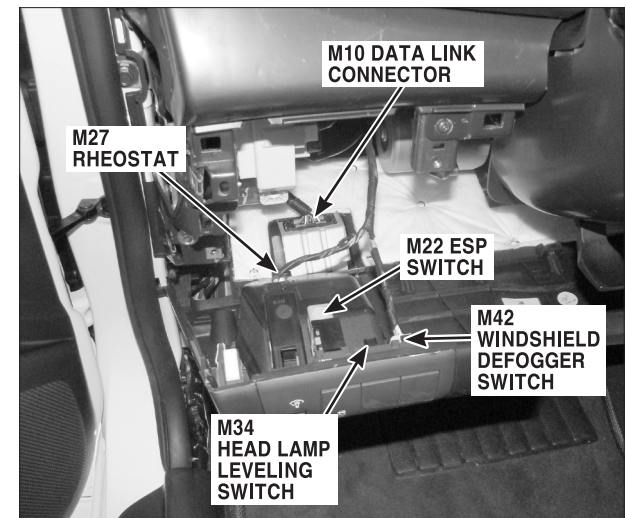

PHOTO.36



# COMPONENT LOCATIONS

## Component Locations (7)

CL-7

PHOTO.37

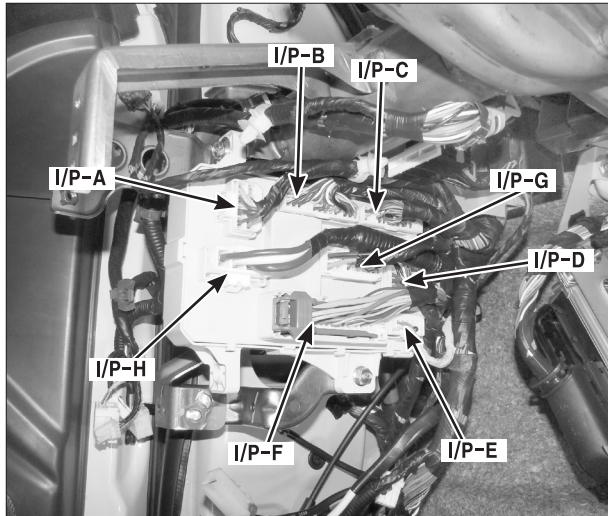

PHOTO.38

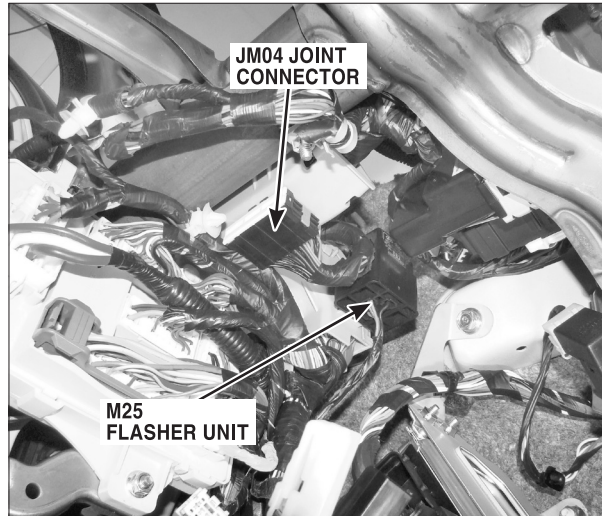

PHOTO.39

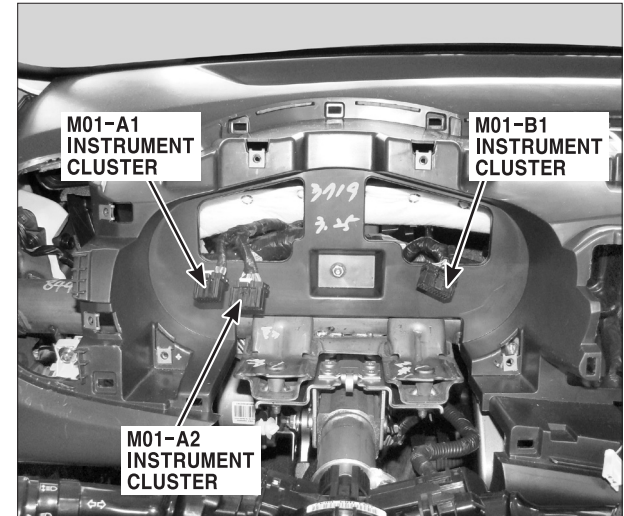

PHOTO.40

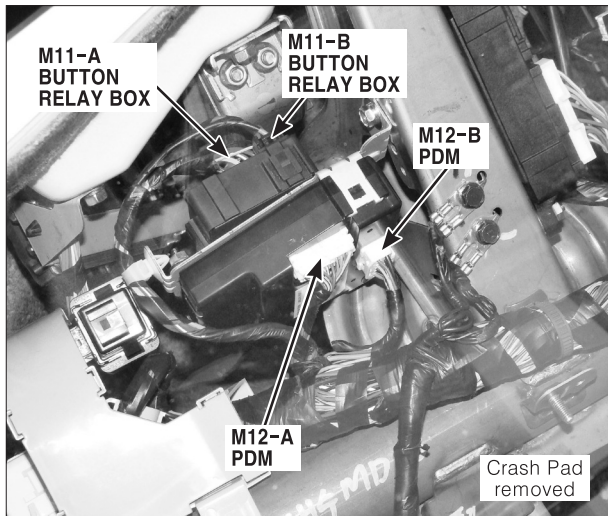

PHOTO.41

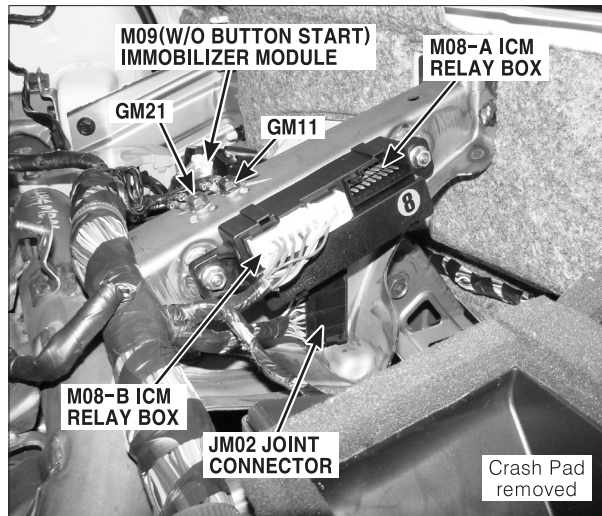
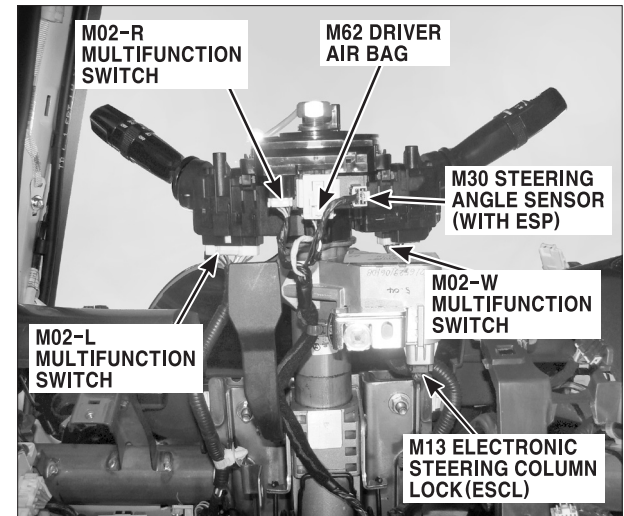

PHOTO.42





# COMPONENT LOCATIONS

## Component Locations (8)

CL-8

PHOTO.43

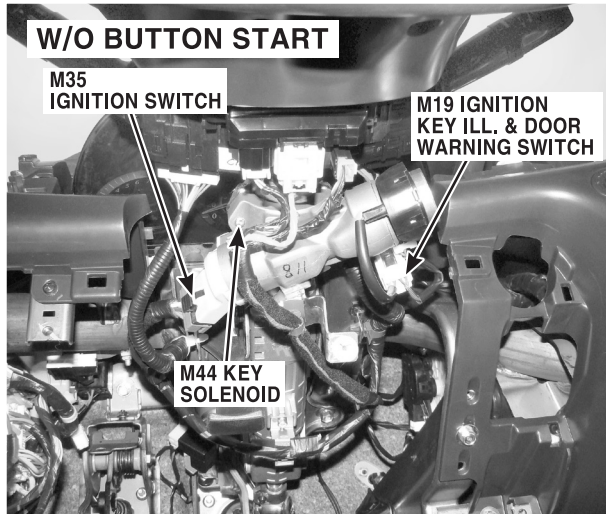

PHOTO.44

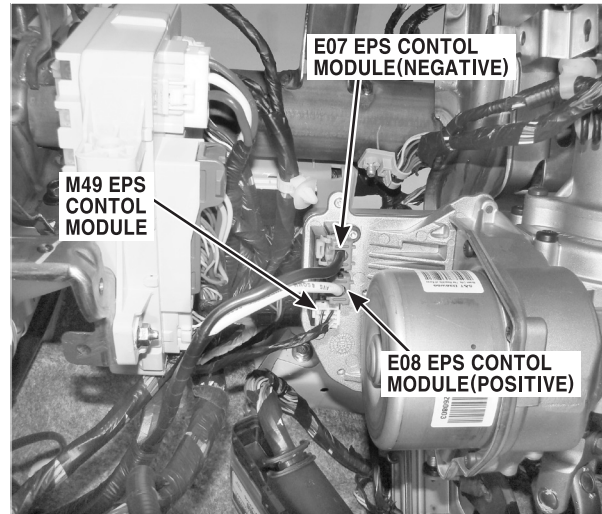

PHOTO.45

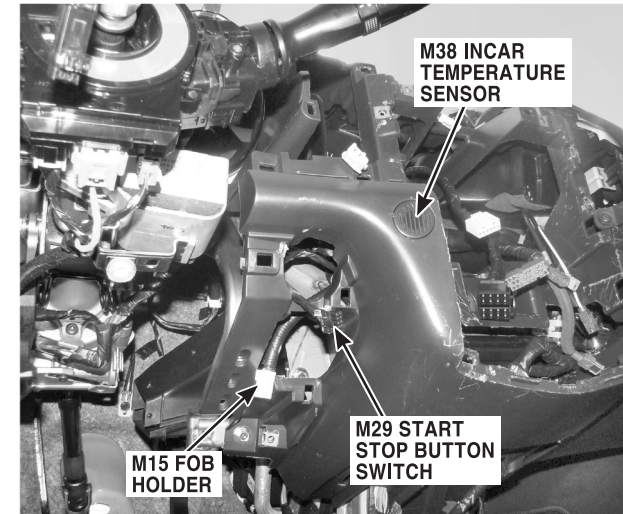

PHOTO.46

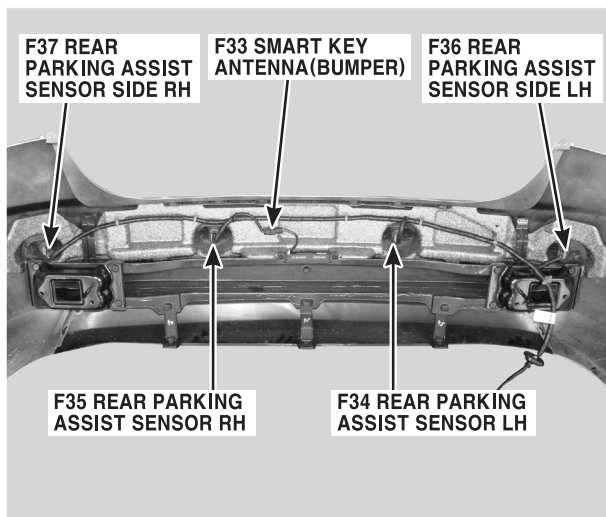

PHOTO.47

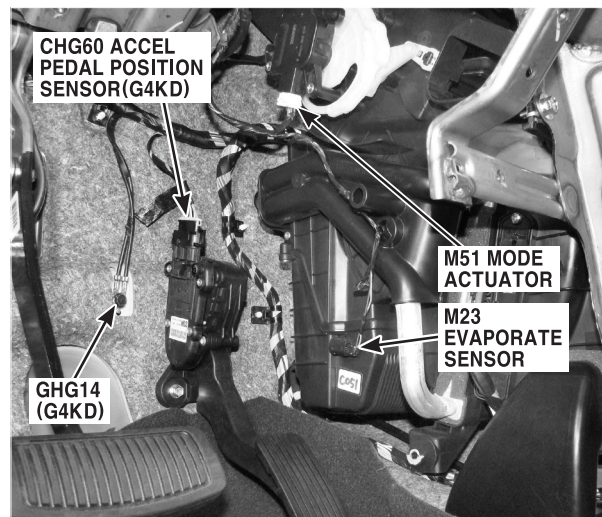
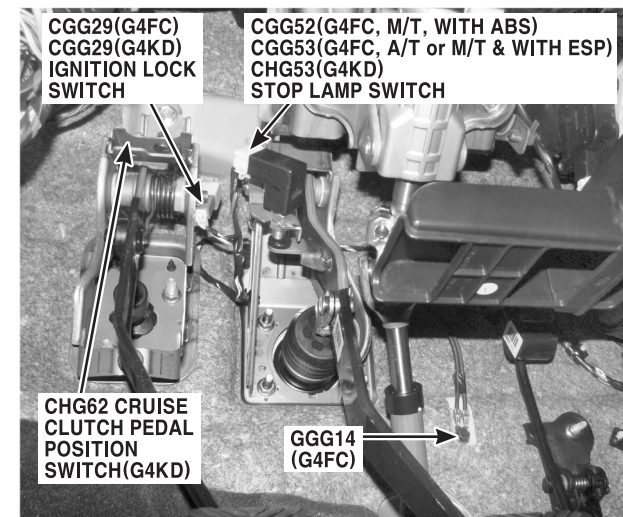

PHOTO.48



# COMPONENT LOCATIONS

## Component Locations (9)

CL-9

PHOTO.49

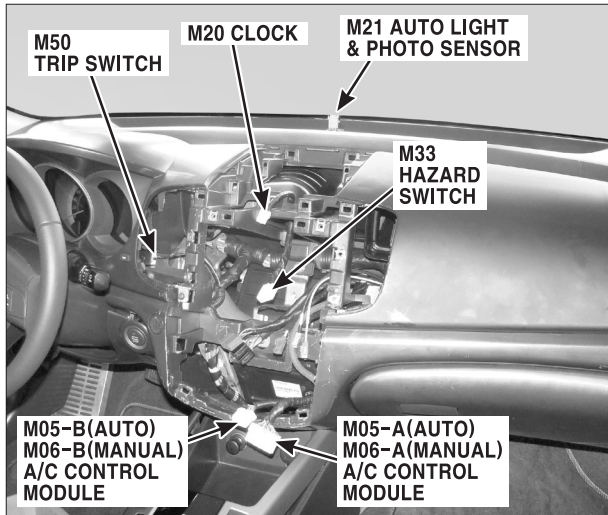

PHOTO.50

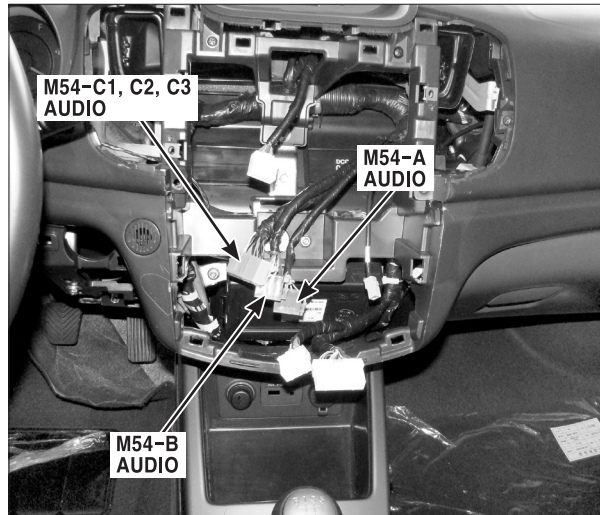

PHOTO.51

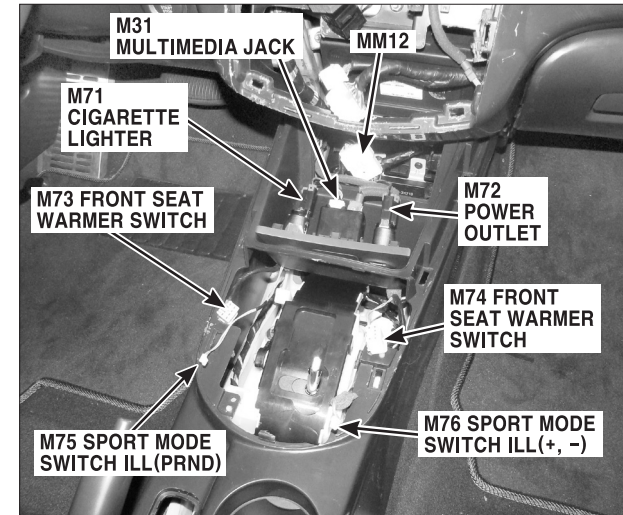

PHOTO.52

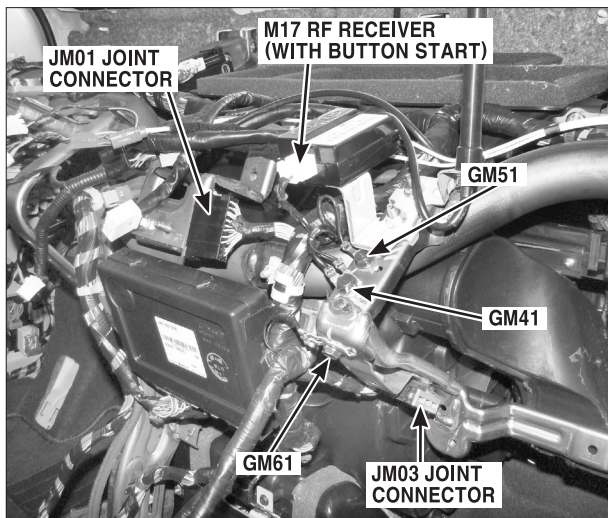

PHOTO.53

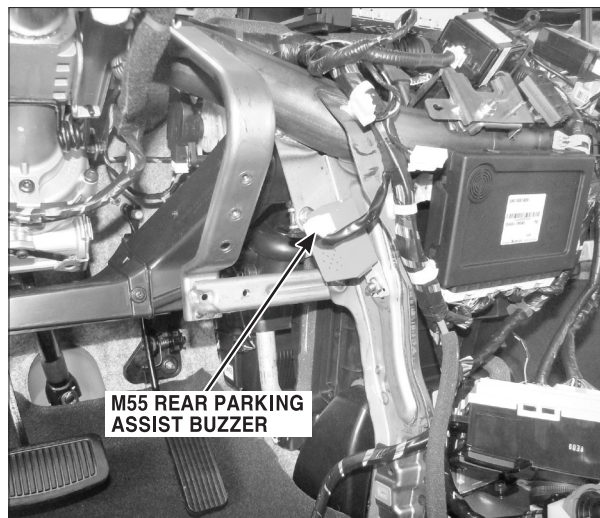
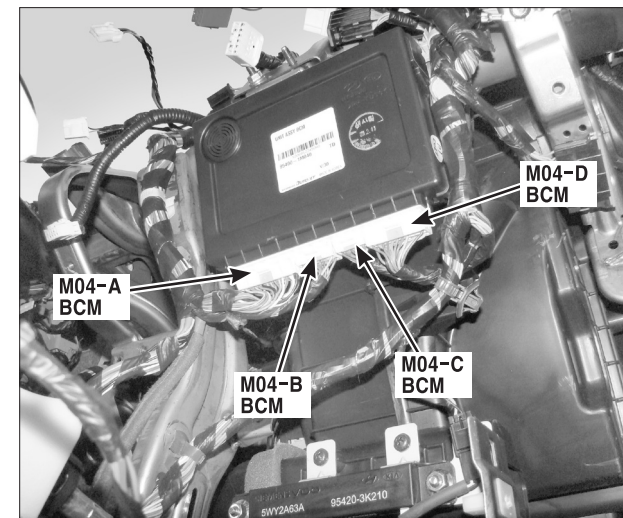

PHOTO.54



# COMPONENT LOCATIONS

## Component Locations (10)

CL-10

PHOTO.55

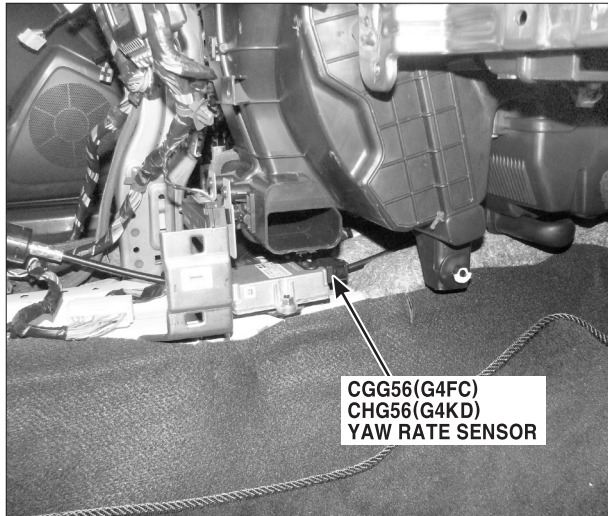

PHOTO.56

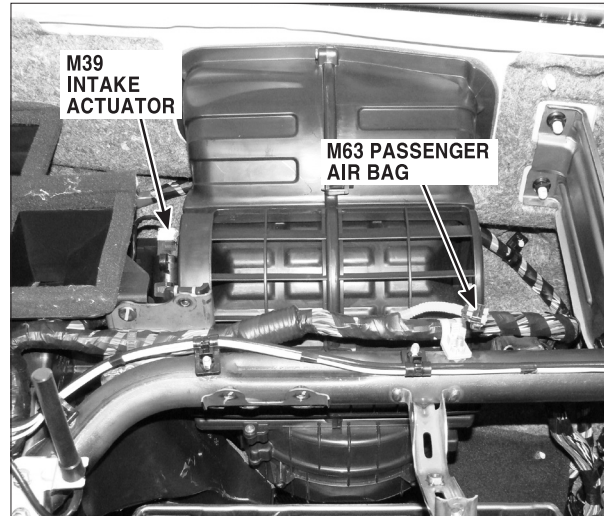

PHOTO.57

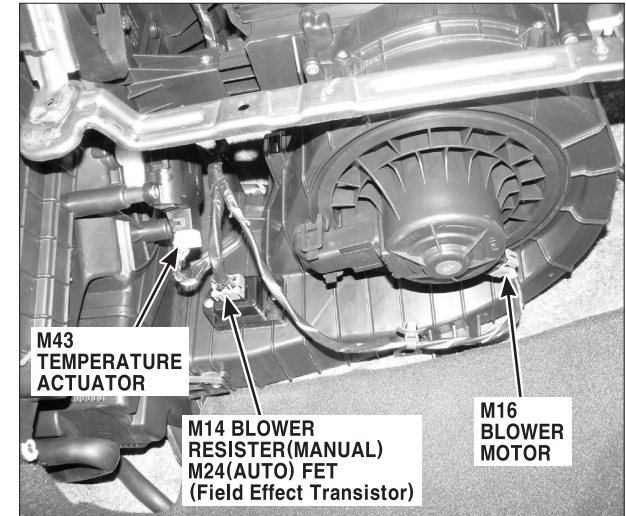

PHOTO.58

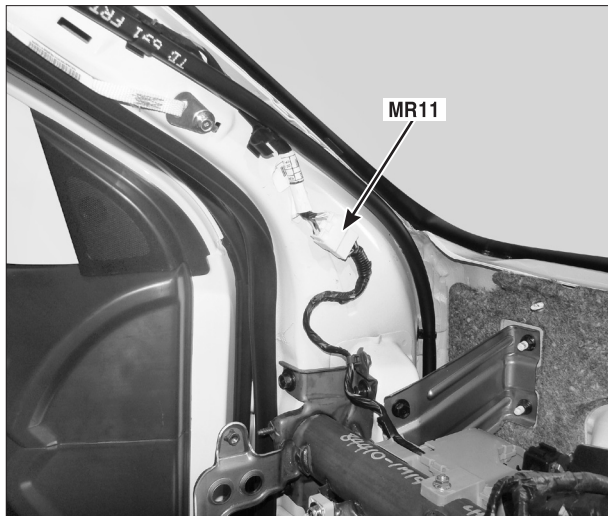

PHOTO.59

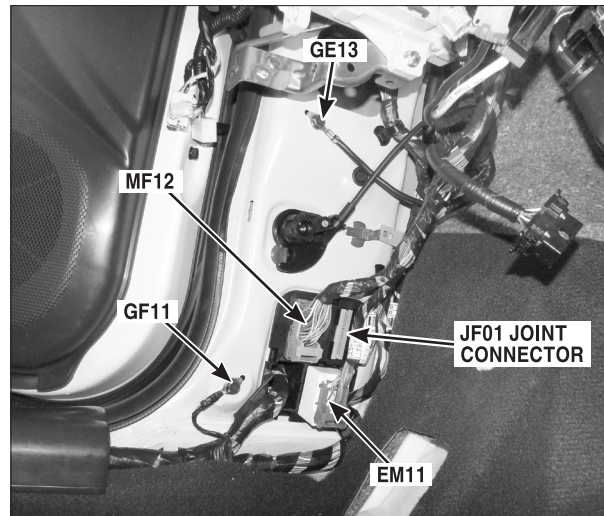
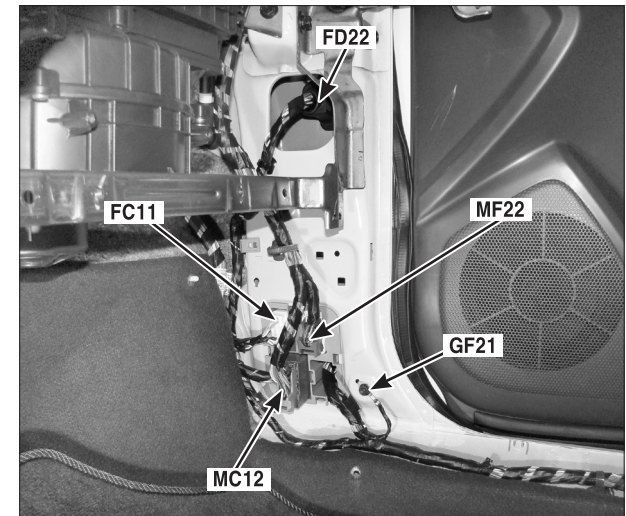

PHOTO.60



# COMPONENT LOCATIONS

## Component Locations (11)

CL-11

PHOTO.61

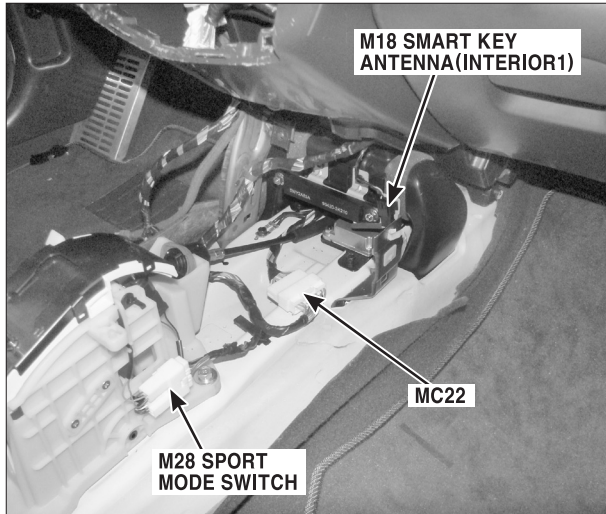

PHOTO.62

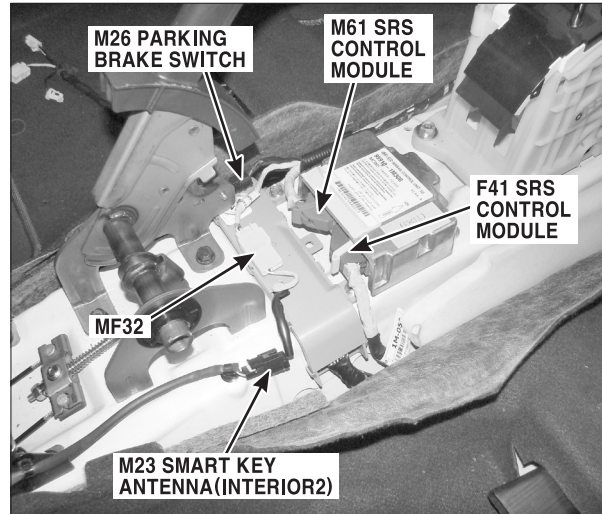

PHOTO.63

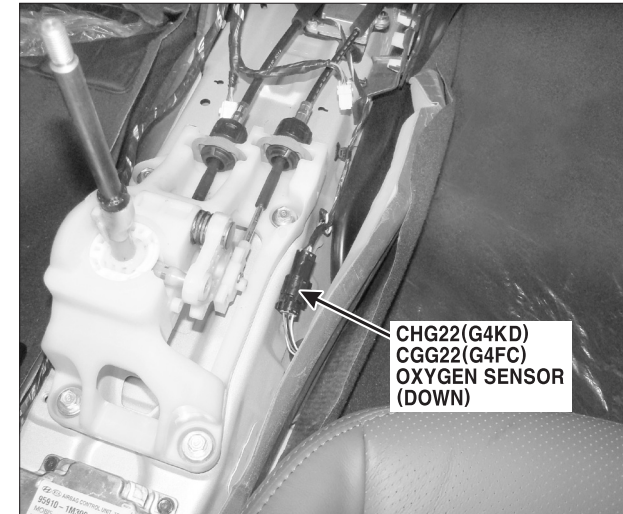

PHOTO.64

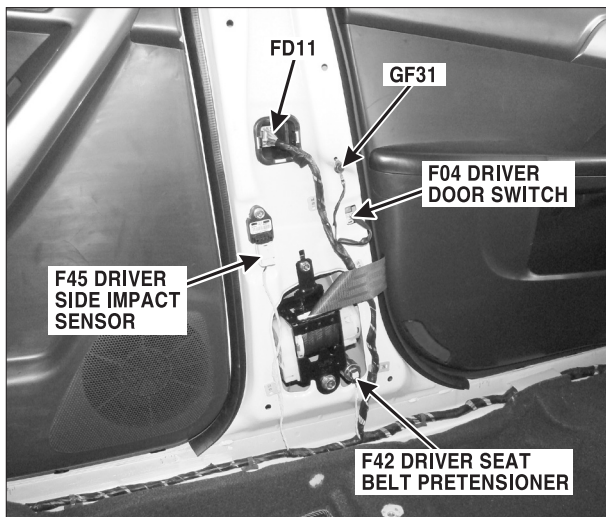

PHOTO.65

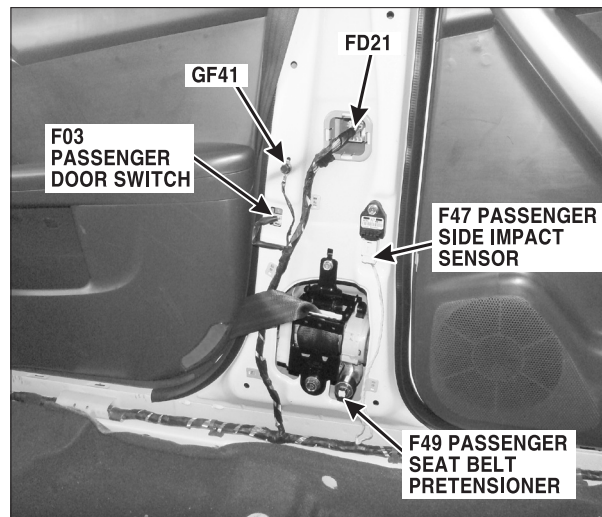
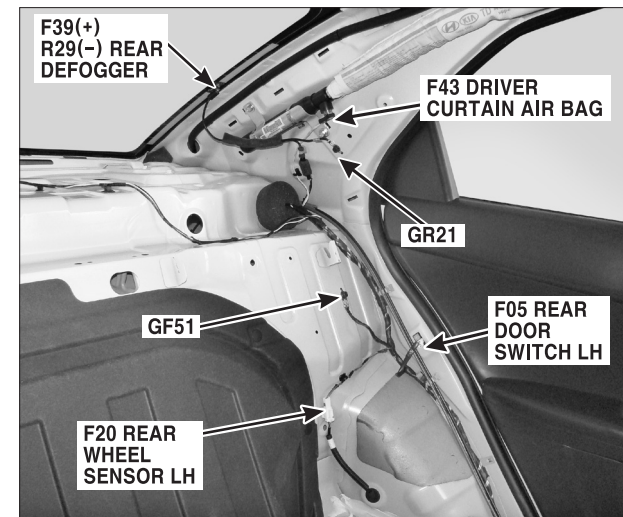

PHOTO.66



# COMPONENT LOCATIONS

## Component Locations (12)

CL-12

PHOTO.67

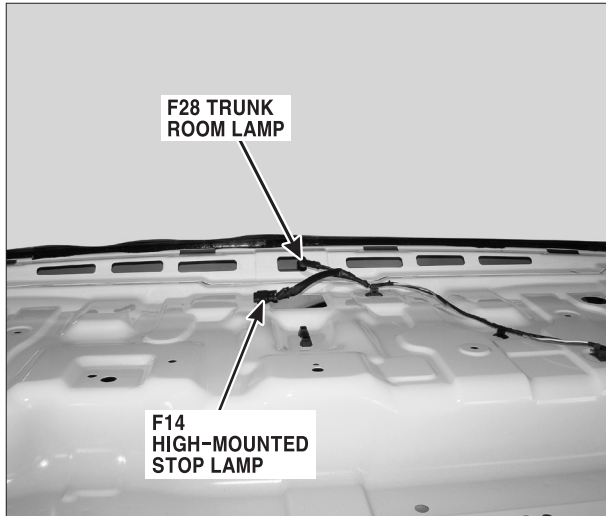

PHOTO.68

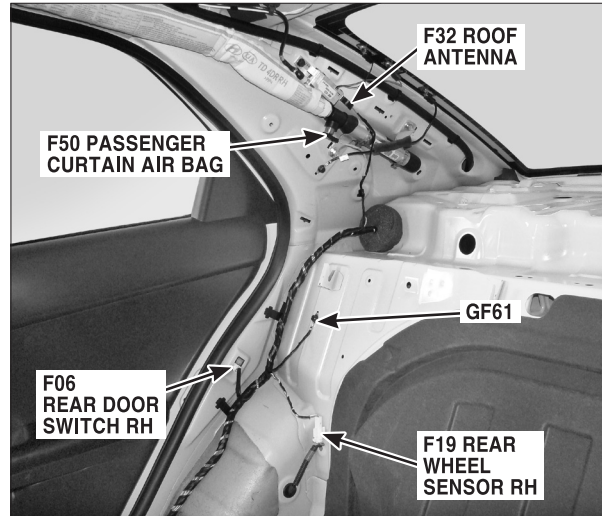

PHOTO.69

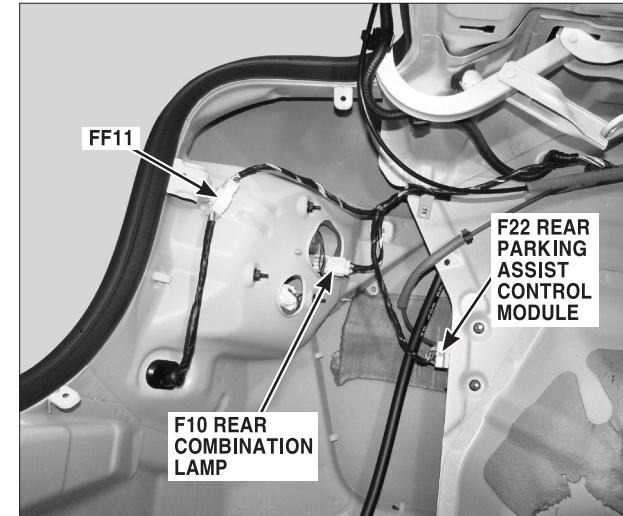

PHOTO.70

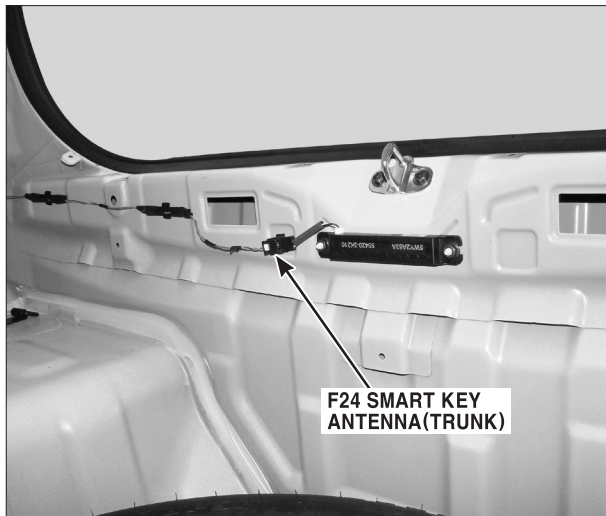

PHOTO.71

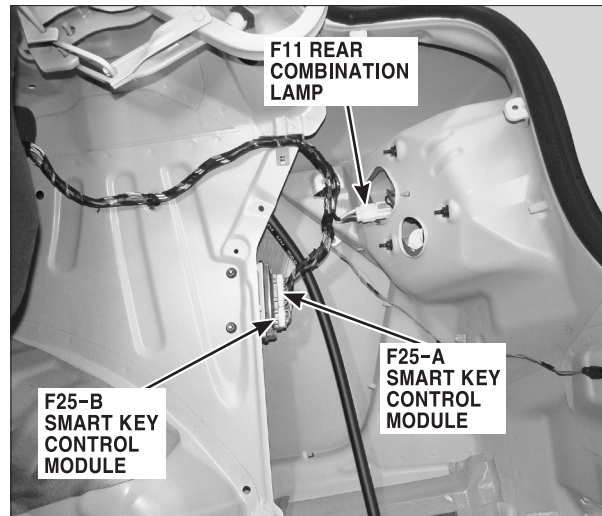
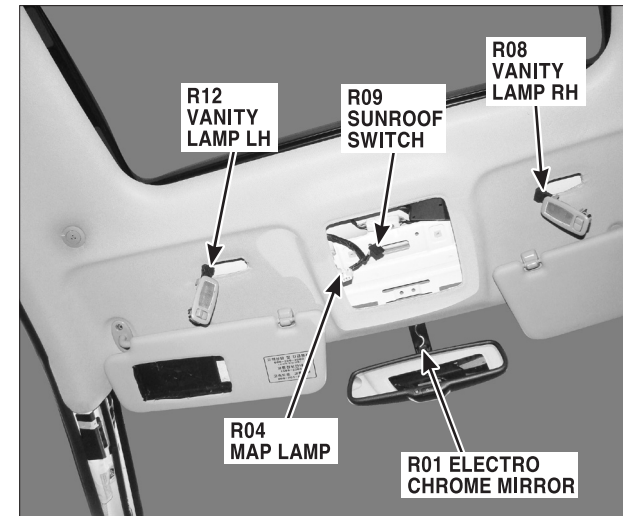

PHOTO.72



# COMPONENT LOCATIONS

## Component Locations (13)

CL-13

PHOTO.73

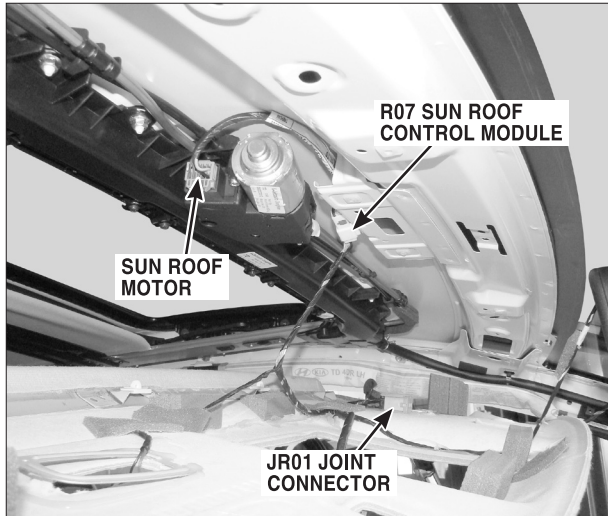

PHOTO.74



PHOTO.75

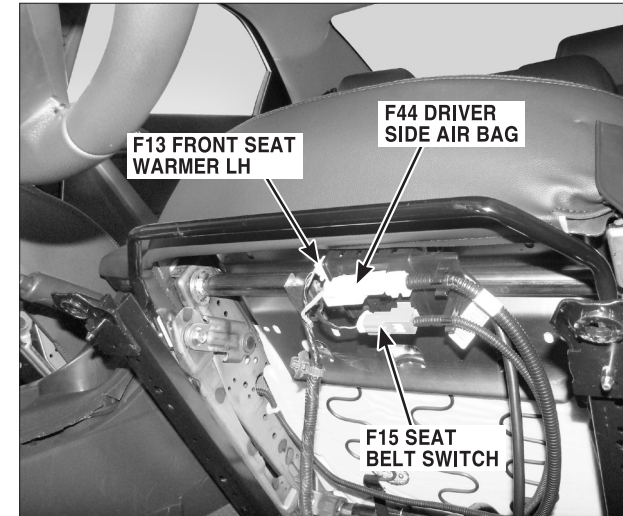

PHOTO.76

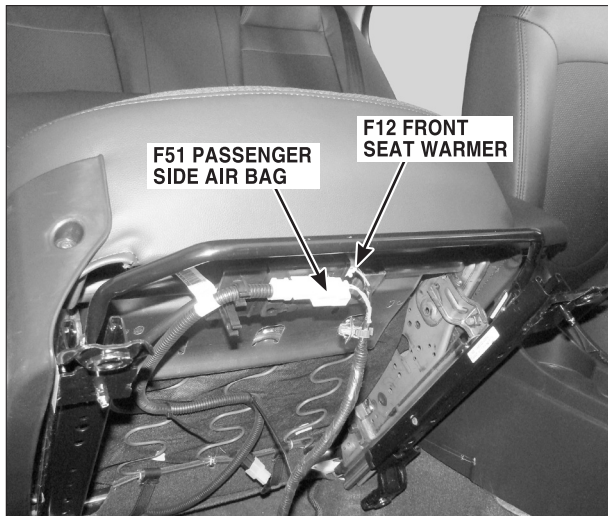

PHOTO.77

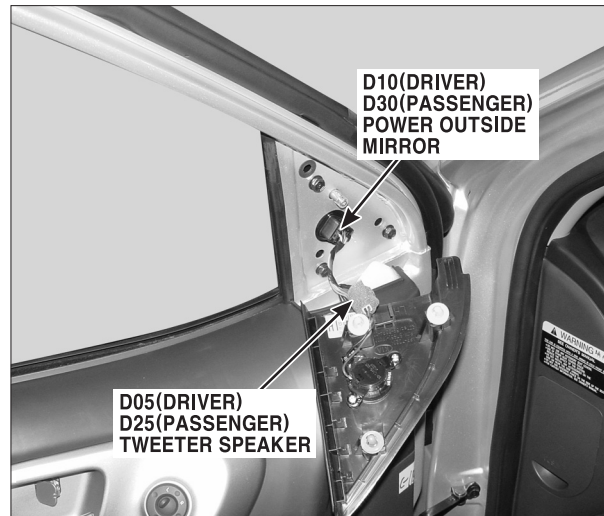
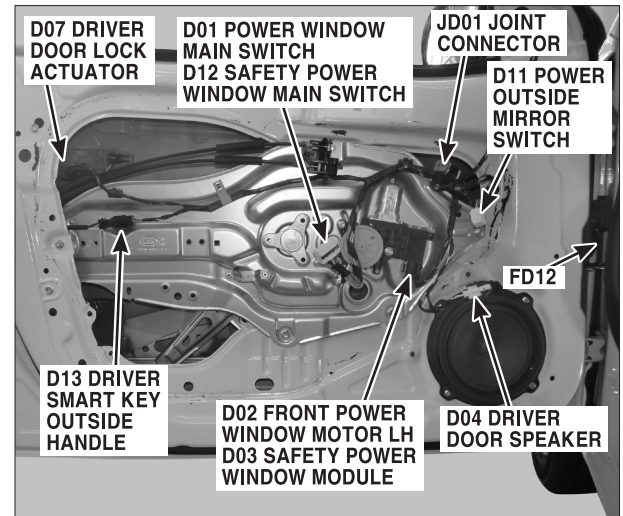

PHOTO.78



# COMPONENT LOCATIONS

## Component Locations (14)

CL-14

PHOTO.79

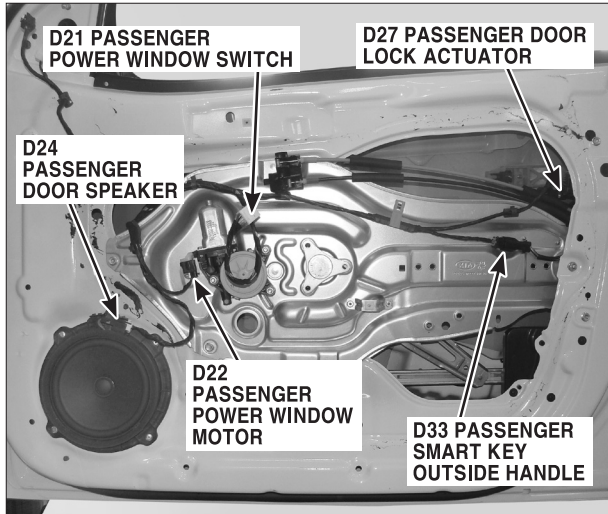

PHOTO.80

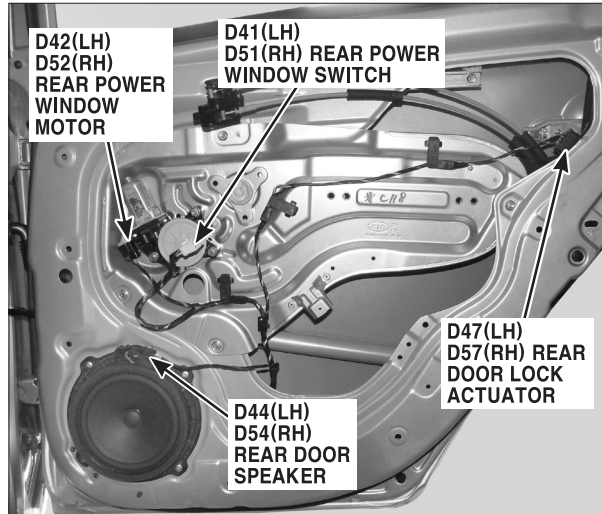
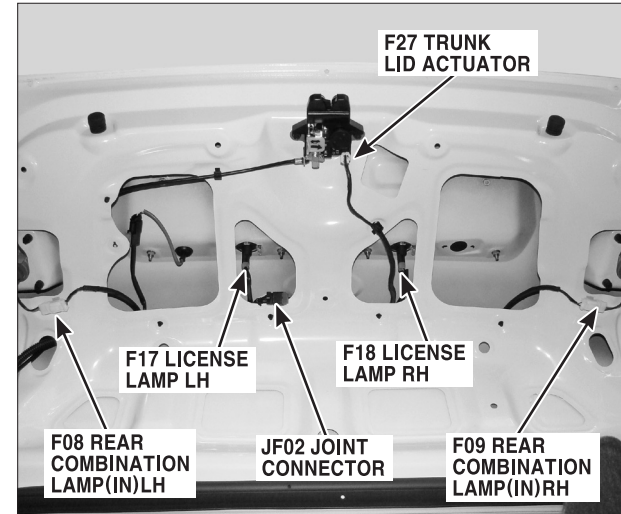

PHOTO.81



# HARNES CONNECTORS

EFFAF0B4

## Harness Connectors (1)

CC-1

### CGGIG(G4FC)

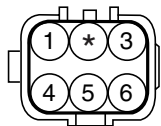

KUM\_NMWP\_06M\_5

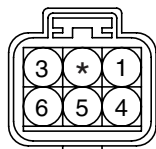

KUM\_NMWP\_06F\_B

### EB11(G4FC)

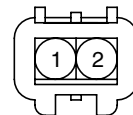

KUM\_NMWP\_02M\_B

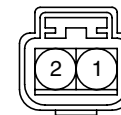

KUM\_NMWP\_02F\_B

### EB11(G4KD)

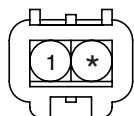

KUM\_NMWP\_02M\_B

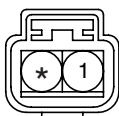

KUM\_NMWP\_02F\_B

### BLANK

### EC11(G4FC)

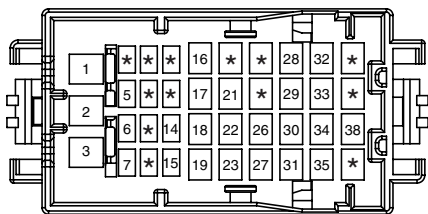

KET\_0409LIF\_39M\_W

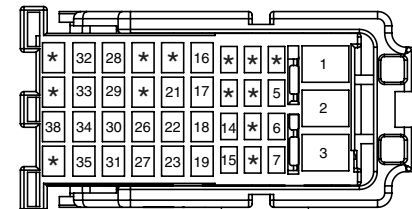

KET\_0409LIF\_39F\_W

### EC11(G4KD)

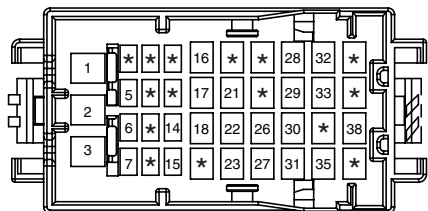

KET\_0409LIF\_39M\_W

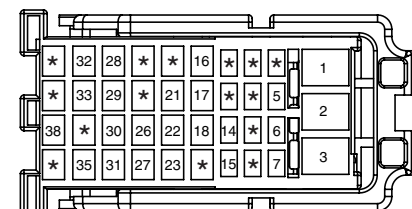

KET\_0409LIF\_39F\_W

### EE12

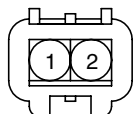

KUM\_NMWP\_02M\_B



KUM\_NMWP\_02F\_B

### EE22

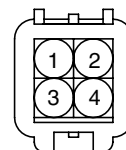

KUM\_NMWP\_04M\_B

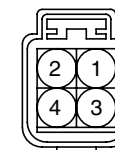

KUM\_NMWP\_04F\_B





# HARNESS CONNECTORS

## Harness Connectors (3)

CC-3

### MC22(G4FC)

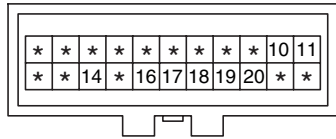

AMP\_090III\_22M\_W

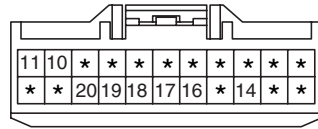

AMP\_090III\_22F\_W

### MC22(G4KD)

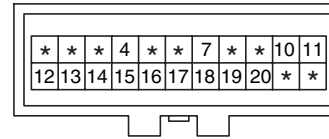

AMP\_090III\_22M\_W

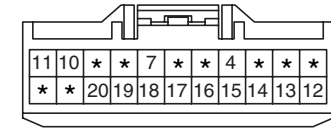

AMP\_090III\_22F\_W

### MF12

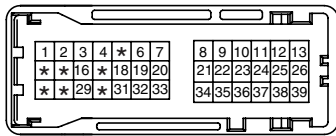

KET\_LIF0409\_39M\_Gr

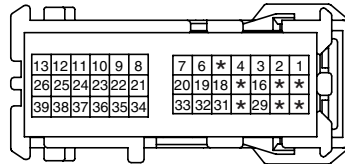

KET\_LIF0409\_39F\_Gr

### MF22

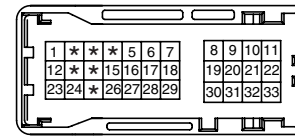

KET\_LIF0409\_33M\_W

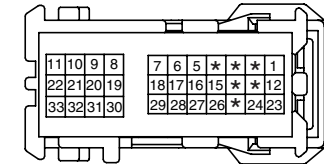

KET\_LIF0409\_33F\_W

### MF32

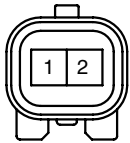

AMP\_090WP\_02M\_B

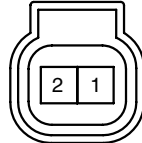

AMP\_090WP\_02F\_B

### MM12

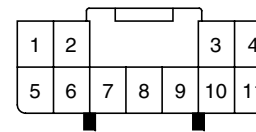

KET\_MMK\_DL\_11M

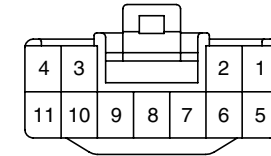

KET\_090II\_11F\_W

### MR11

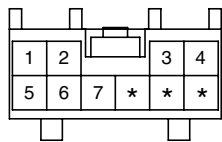

AMP\_090III\_10M\_W

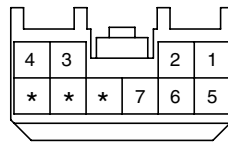

AMP\_090III\_10F\_W

BLANK

**Engine Compartment Junction Box (1)** **CC-4**

**E/R-CGG1**

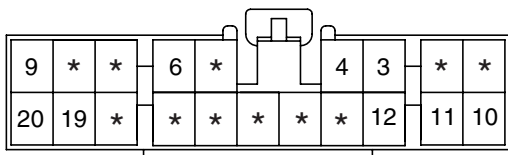

KET\_090III\_20F\_Gr

**E/R-CGG2**

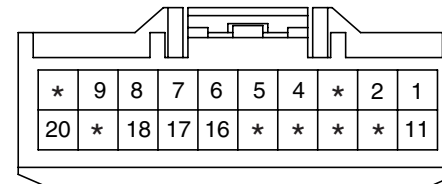

KET\_090III\_20F\_W

**E/R-CHG1**

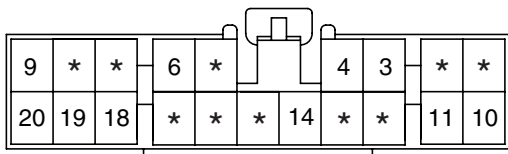

KET\_090III\_20F\_Gr

**E/R-CHG2**

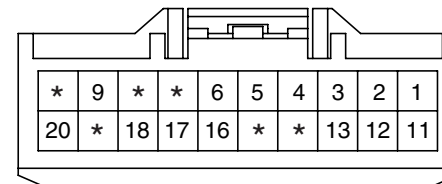

KET\_090III\_20F\_W

**E/R FUSE & RELAY BOX**

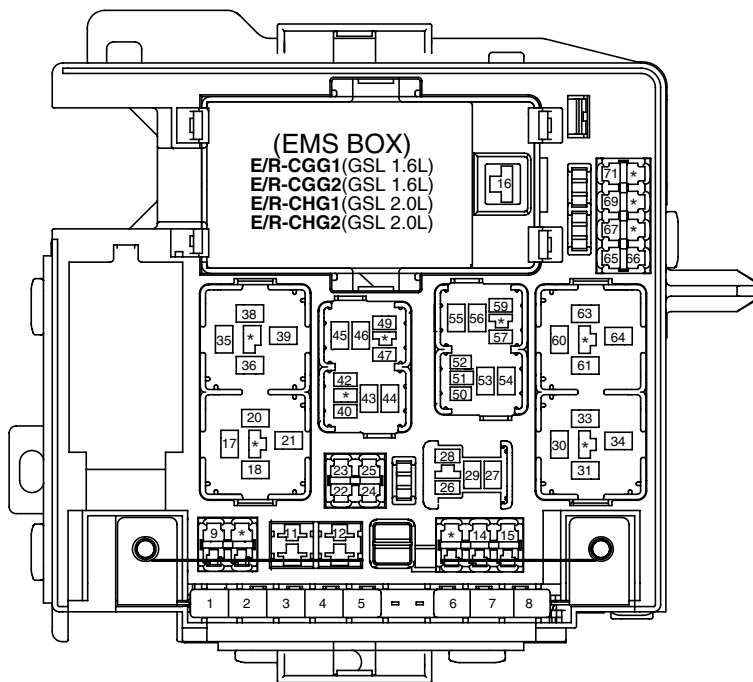

TD\_EROOMBOX\_72F\_B

**BLANK**

**PASSENGER COMPARTMENT JUNCTION BOX** EDCDB6F6

**Passenger Compartment Junction Box (1)**

**CC-5**

**I/P-A**

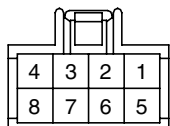

KET\_187II\_08F\_W

**I/P-B**

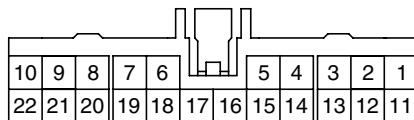

KET\_090III\_22F\_W

**I/P-C**

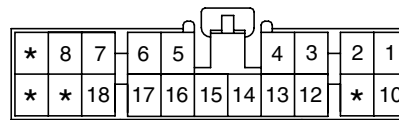

KET\_090III\_20F\_W

**I/P-D**

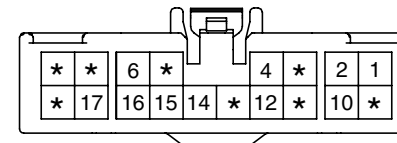

KET\_090III\_18F\_W

**I/P-E**

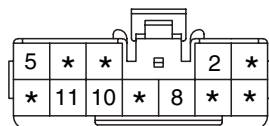

KET\_090II\_12F\_W

**I/P-F**

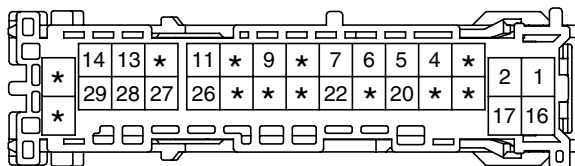

KET\_LIF09187\_30F\_W

**I/P-G**

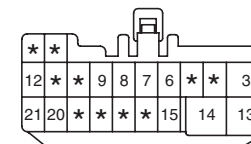

KET\_1809\_21F\_W\_A

**I/P-H**

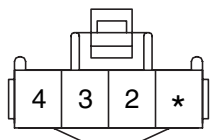

KET\_312II\_04F\_W

**BLANK**

**BLANK**

**BLANK**

**Joint Connectors (1)**

**CC-6**

**JD01**

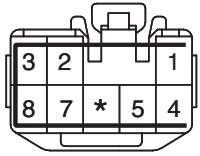

KET\_090II\_08F\_W

**JF01**

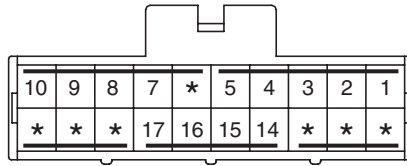

KET\_090II\_20F\_B\_JCH

**JF02**

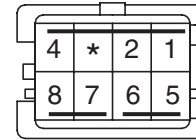

KET\_070\_08F\_B\_JCH

**JM01**

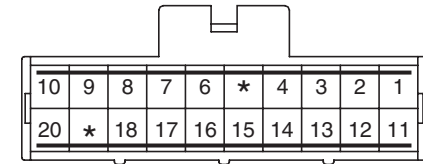

KET\_090II\_20F\_B\_JCH

**JM02**

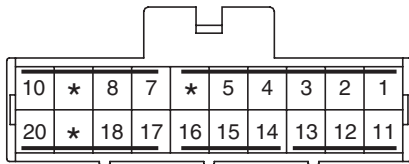

KET\_090II\_20F\_B\_JCH

**JM03**

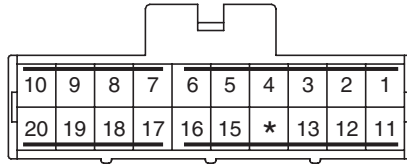

KET\_090II\_20F\_B\_JCH

**JM04**

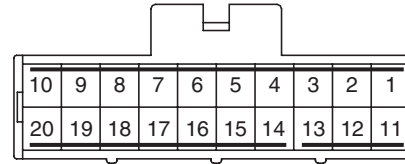

KET\_090II\_20F\_B\_JCH

**JR01**

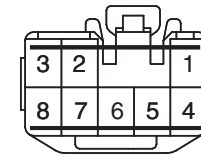

KET\_090II\_08F\_B

Main Harness (1)

HL-1

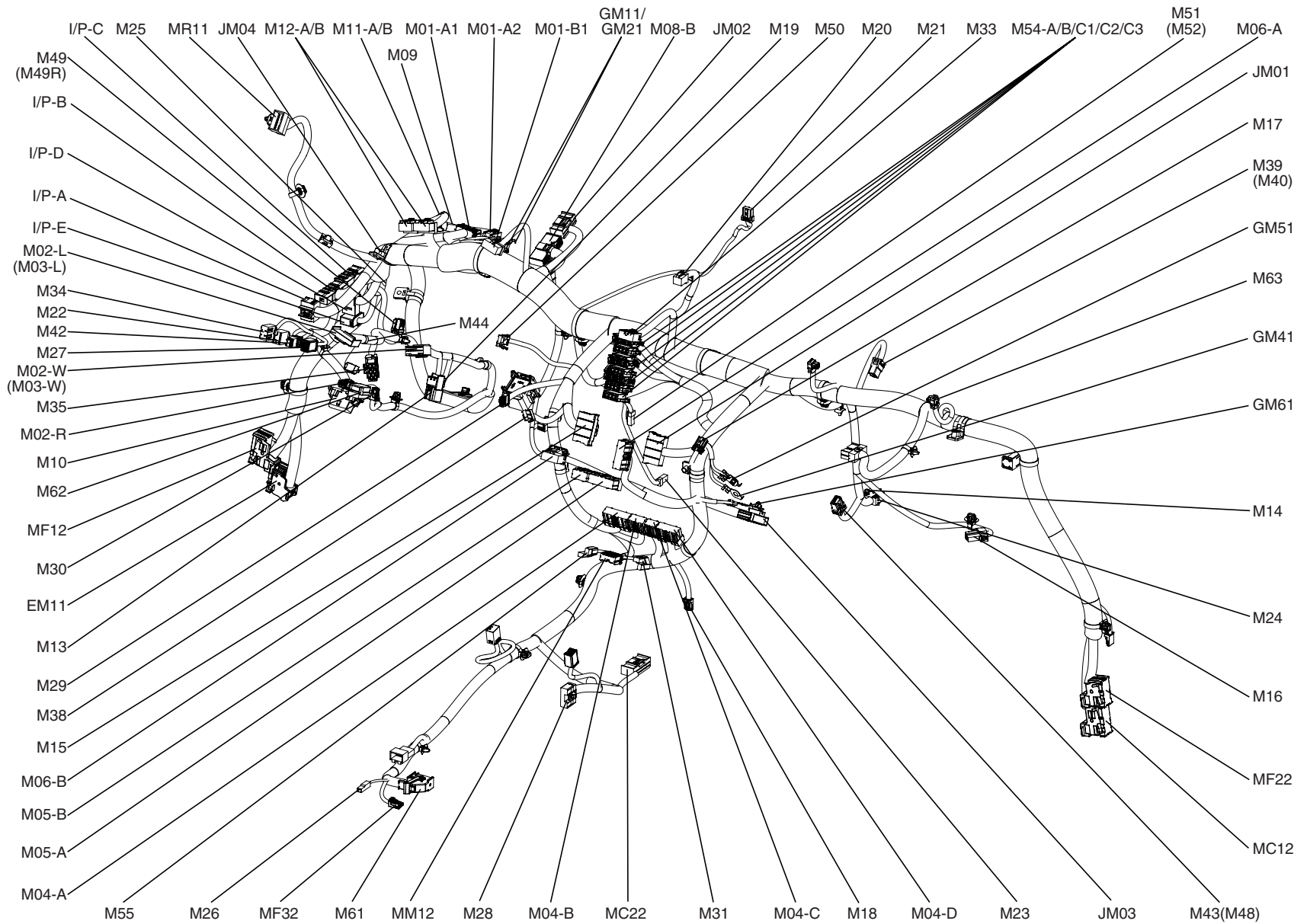

( ): RHD



Front & Front End Module Harness (1)

HL-3

Front Harness

Front End Module Harness

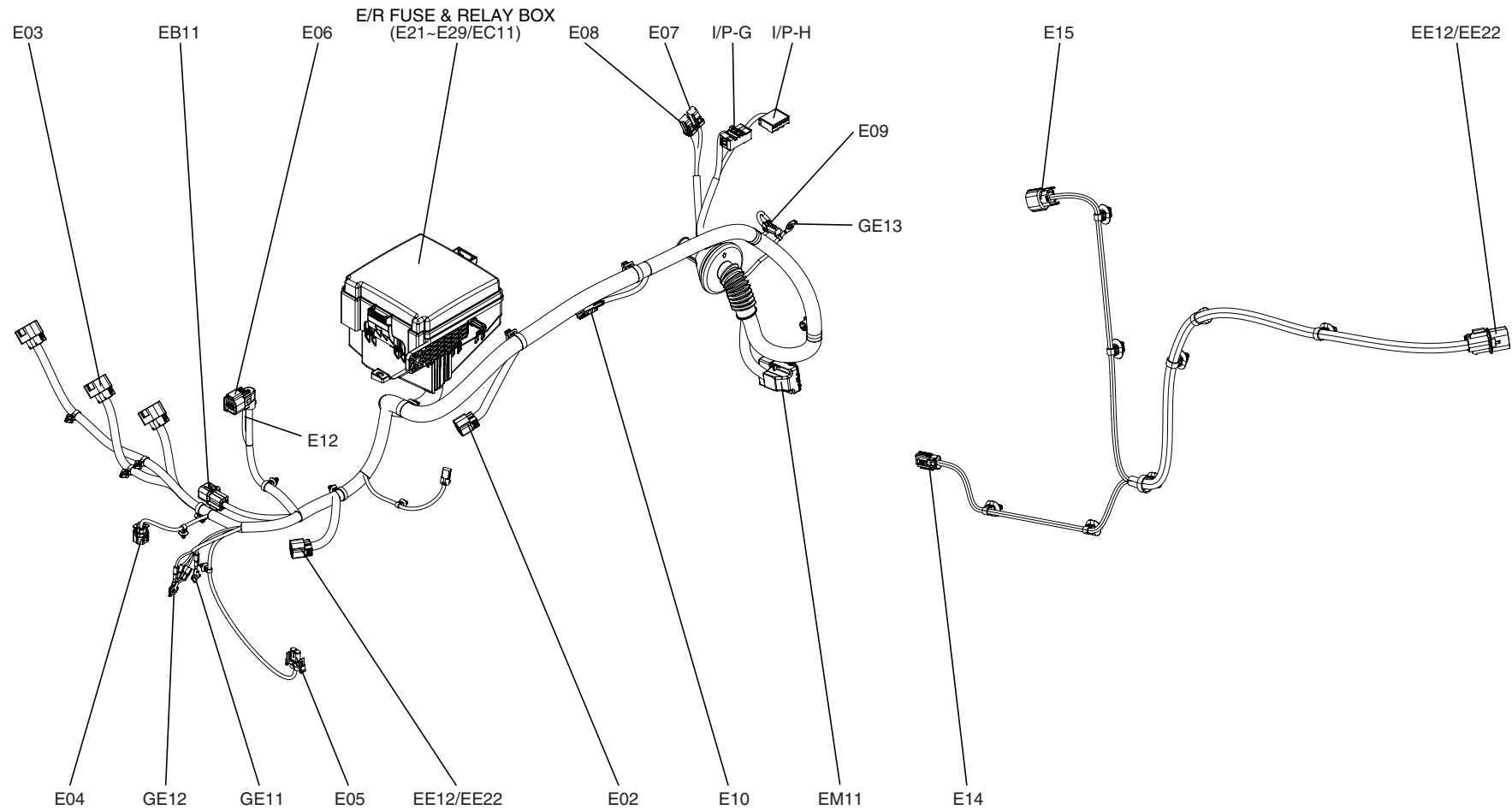



## FRONT & FRONT END MODULE HARNESS

### Front & Front End Module Harness (2)

HL-4

#### FRONT HARNESS

E02	External buzzer (With button starting)
E03	Cooling fan motor
E04	Front impact sensor LH
E05	Front fog lamp LH
E06	Head lamp LH
E07	EPS control module
E08	EPS control module
E09	Side repeater lamp LH
E10	Front wheel sensor LH (With ABS/ESP)
E12	Head lamp leveling actuator LH
E21	Blower relay
E22	Start relay
E23	H/LP(HI) relay
E24	Front fog relay
E25	Horn relay
E26	Wiper relay
E27	H/LP(LO) relay
E28	C/FAN HI relay
E29	C/FAN LO relay
I/P-G	Connection with I/P JUNCTION BOX harness
I/P-H	Connection with I/P JUNCTION BOX harness
EB11	Connection with BATTERY harness
EC11	Connection with CONTROL harness
EE12	Connection with FRONT END MODULE harness
EE22	Connection with FRONT END MODULE harness
EM11	Connection with MAIN harness
GE11	Ground
GE12	Ground
GE13	Ground

#### FRONT END MODULE HARNESS

E14	Ambient sensor
E15	Horn (Low)
EE12	Connection with FRONT harness
EE22	Connection with FRONT harness

**Battery Harness (G4FC)**

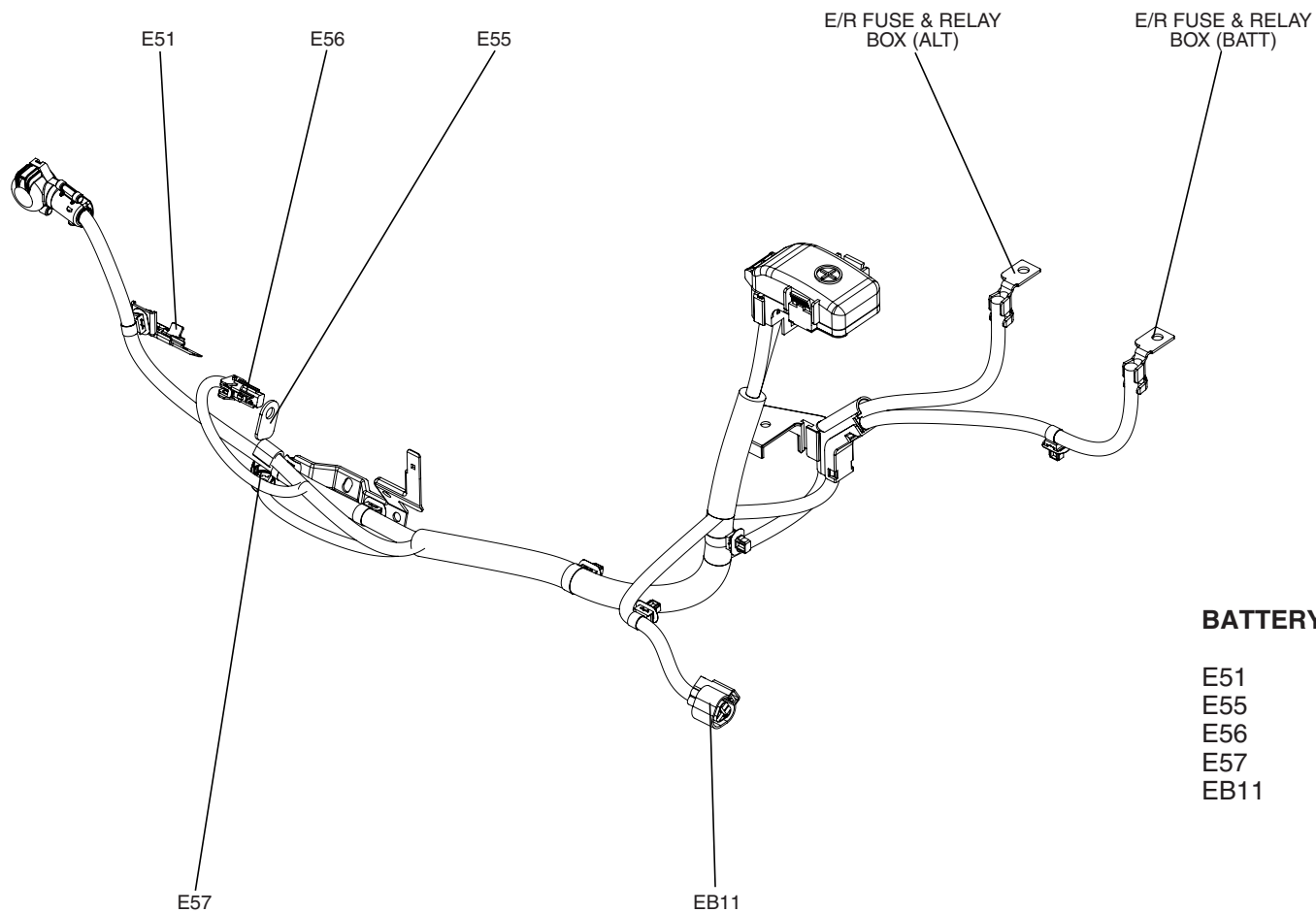

**BATTERY HARNESS**

- E51 Generator
- E55 Start motor
- E56 Start solenoid
- E57 Oil pressure switch
- EB11 Connection with FRONT harness

# BATTERY HARNESS

## Battery Harness (2)

HL-6

### Battery Harness (G4KD)

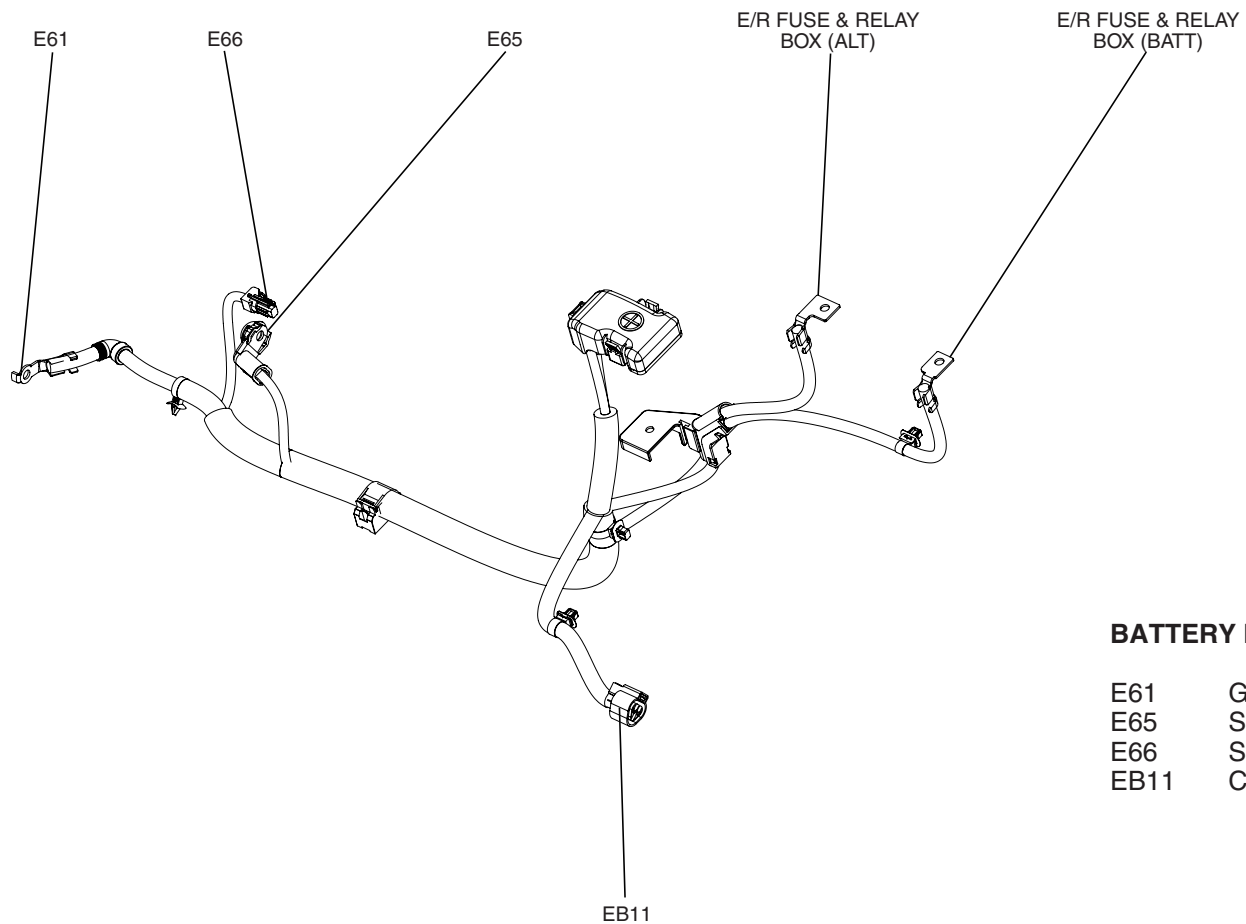

### BATTERY HARNESS

- |      |                               |
|------|-------------------------------|
| E61  | Generator                     |
| E65  | Start motor                   |
| E66  | Start solenoid                |
| EB11 | Connection with FRONT harness |

Floor Harness (1)

HL-7

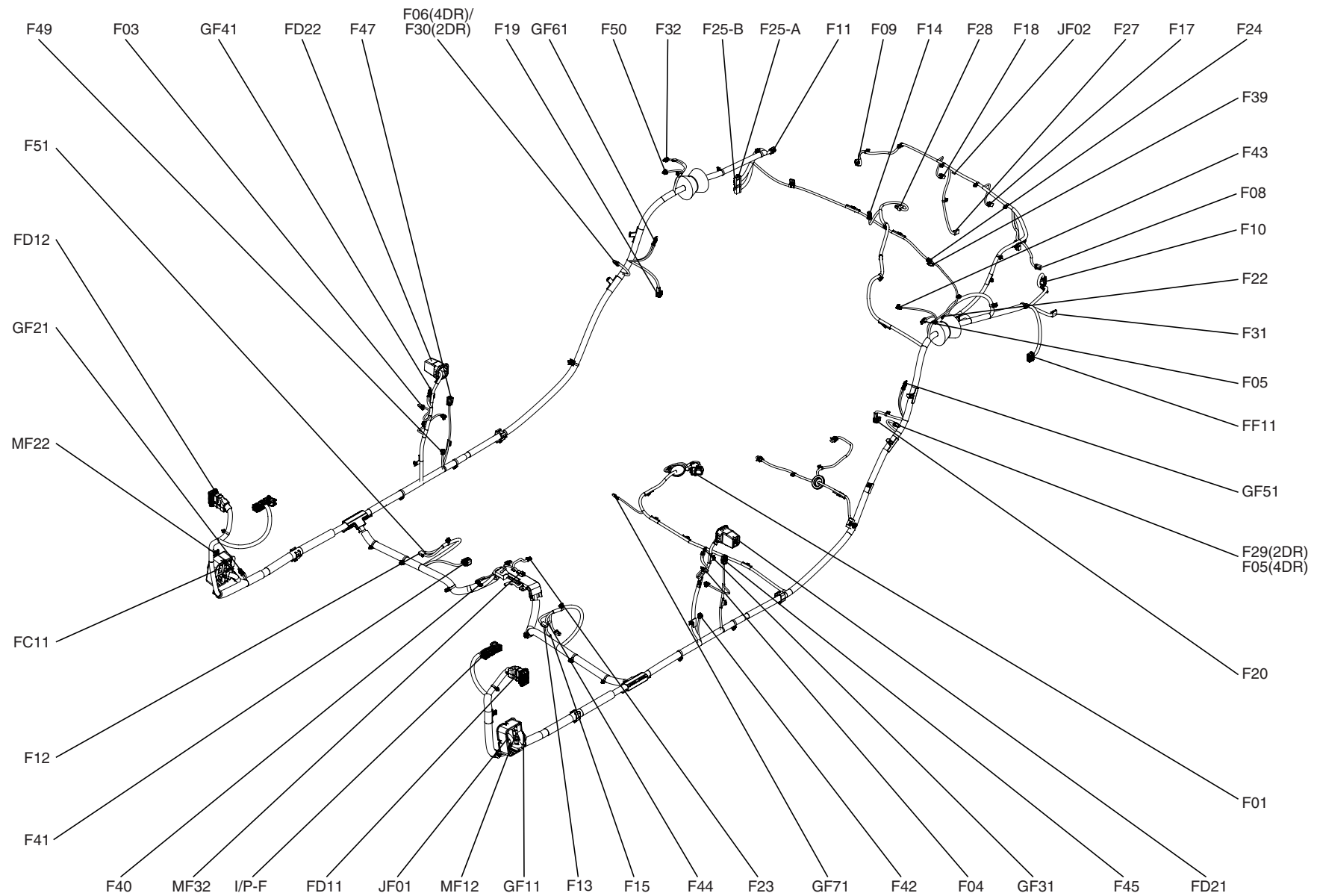

## FLOOR HARNESS

### Floor Harness (2)

HL-8

#### FLOOR HARNESS

F01	Fuel sender & Fuel pump motor	F42	Driver seat belt pretensioner
F03	Passenger door switch	F43	Driver curtain air bag
F04	Driver door switch	F44	Driver side air bag
F05	Rear door switch LH	F45	Driver side impact sensor
F06	Rear door switch RH	F47	Passenger side impact sensor
F08	Rear combination lamp (In) LH	F49	Passenger seat belt pretensioner
F09	Rear combination lamp (In) RH	F50	Passenger curtain air bag
F10	Rear combination lamp (Out) LH	F51	Passenger side air bag
F11	Rear combination lamp (Out) RH	JF01	Joint connector
F12	Front seat warmer RH	JF02	Joint connector
F13	Front seat warmer LH	I/P-F	Connection with I/P JUNCTION BOX harness
F14	High-mounted stop lamp	FD11	Connection with REAR DOOR LH harness
F15	Seat belt switch	FD12	Connection with DRIVER DOOR harness
F17	License lamp LH (4DR)	FD21	Connection with REAR DOOR RH harness
F18	License lamp RH (4DR)	FD22	Connection with ASSIST DOOR harness
F19	Rear wheel sensor RH	FF11	Connection with BWS EXT. harness
F20	Rear wheel sensor LH	FC11	Connection with CONTROL harness
F22	Rear parking assist control module	MF12	Connection with MAIN harness
F23	Smart key antenna (Interior 2) (With smart key)	MF22	Connection with MAIN harness
F24	Smart key antenna (Trunk) (With smart key)	MF32	Connection with MAIN (A/BAG) harness
F25-A	Smart key control module	GF11	Ground
F25-B	Smart key control module	GF21	Ground
F27	Trunk lid actuator	GF31	Ground
F28	Trunk room lamp	GF41	Ground
F29	Rear speaker LH (2DR)	GF51	Ground
F30	Rear speaker RH (2DR)	GF61	Ground
F31	License lamp (2DR) (W/O rear parking assist )	GF71	Ground
F32	Roof antenna		
F39	Rear defogger (+)		
F40	Parking brake switch (RHD)		
F41	SRS control module		

Control Harness (1)

HL-9

G4FC - GSL 1.6L

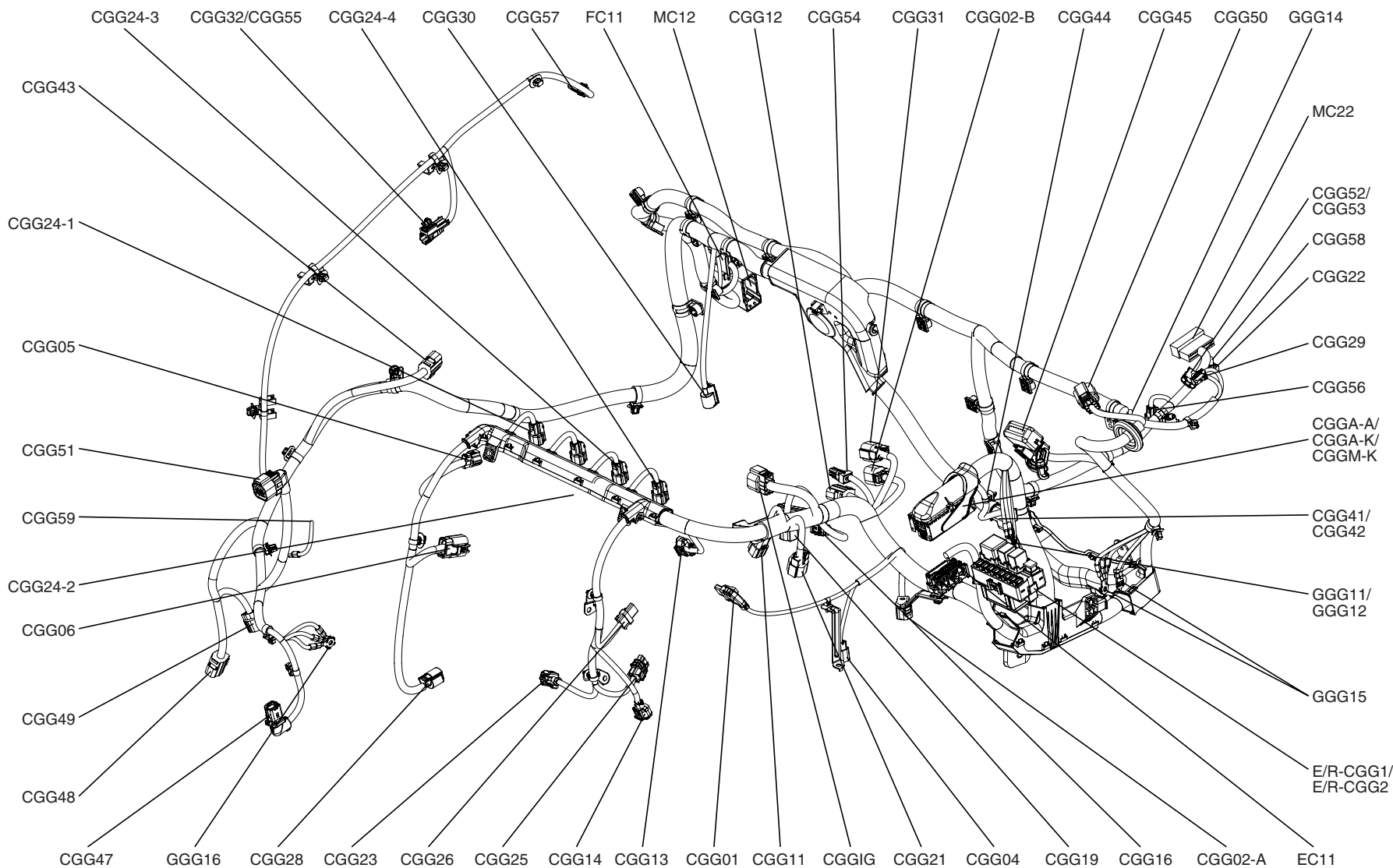

## CONTROL HARNESS

### Control Harness (2)

HL-10

#### CONTROL HARNESS (G4FC)

CGG01	Transaxle range switch	CGG52	Stop lamp switch (With M/T & ABS)
CGG02-A	Pulse generator 'A'	CGG53	Stop lamp switch (With A/T or M/T & ESP)
CGG02-B	Pulse generator 'B'	CGG54	Back up lamp switch (M/T)
CGG04	ATM solenoid valve	CGG55	Front wheel sensor RH
CGG05	Oil control valve	CGG56	Yaw rate sensor
CGG06	Generator	CGG57	Side repeater lamp RH
CGG11	Engine coolant temperature sensor & sender	CGG58	Windshield defogger
CGG12	Throttle position sensor	CGG59	Head lamp leveling actuator RH
CGG13	Camshaft position sensor	CGGA-A	PCM (A/T)
CGG14	Crankshaft position sensor	CGGA-K	PCM (A/T)
CGG16	Oxygen sensor (Up)	CGGM-K	ECM (M/T)
CGG19	Condenser	E/R-CGG1	EMS box
CGG21	Canister purge solenoid valve	E/R-CGG2	EMS box
CGG22	Oxygen sensor (Down)	CGGIG	Connection with IGNITION COIL harness
CGG23	Knock sensor	EC11	Connection with FRONT harness
CGG24-1	Injector #1	FC11	Connection with FRONT harness
CGG24-2	Injector #2	MC12	Connection with MAIN harness
CGG24-3	Injector #3	MC22	Connection with MAIN harness
CGG24-4	Injector #4	GGG11	Ground
CGG25	Map sensor	GGG12	Ground (A/T)
CGG26	Idle speed control actuator	GGG13	Ground (M/T)
CGG28	A/C compressor	GGG14	Ground (ABS)
CGG29	Ignition lock switch	GGG15	Ground
CGG30	Power steering switch	GGG16	Ground
CGG31	Vehicle speed sensor (M/T)		
CGG32	Front wheel sensor RH (W/O ABS/ESP)		
CGG41	ABS control module		
CGG42	ESP control module		
CGG43	A/C pressure transducer	CGG18-1	Ignition coil #1
CGG44	Brake oil level sensor	CGG18-2	Ignition coil #2
CGG45	Multipurpose check connector	CGG18-3	Ignition coil #3
CGG47	Front impact sensor RH	CGG18-4	Ignition coil #4
CGG48	Front fog lamp RH	CGGIG	Connection with CONTROL harness
CGG49	Front washer motor		
CGG50	Front wiper motor		
CGG51	Head lamp RH		

#### IGNITION COIL HARNESS

CGG18-1	Ignition coil #1
CGG18-2	Ignition coil #2
CGG18-3	Ignition coil #3
CGG18-4	Ignition coil #4
CGGIG	Connection with CONTROL harness

# CONTROL HARNESS

## Control Harness (3)

HL-11

### G4KD - GSL 2.0L

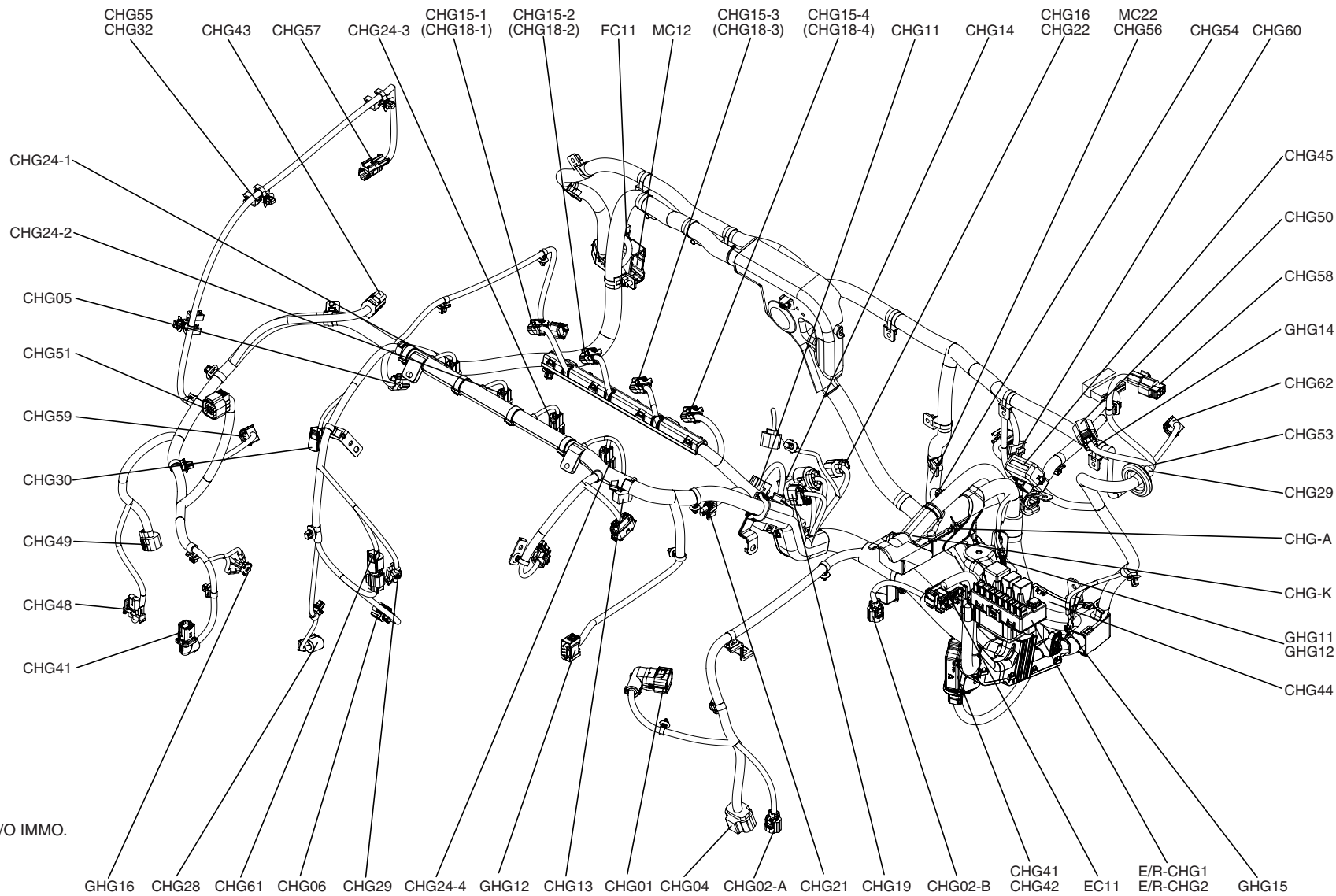



## CONTROL HARNESS

### Control Harness (4)

HL-12

#### CONTROL HARNESS (G4KD)

CHG01	Transaxle range switch	CHG43	A/C pressure transducer
CHG02-A	Pulse generator 'A'	CHG44	Brake oil level sensor
CHG02-B	Pulse generator 'B'	CHG45	Multipurpose check connector
CHG04	ATM solenoid valve	CHG47	Front impact sensor RH
CHG05	Oil control valve	CHG48	Front fog lamp RH
CHG06	Generator	CHG49	Front washer motor
CHG11	Engine coolant temperature sensor & Sender	CHG50	Front wiper motor
CHG12	ETC motor & Throttle position sensor	CHG51	Head lamp RH
CHG13	Camshaft position sensor	CHG53	Stop lamp switch
CHG14	Crankshaft position sensor	CHG54	Back up lamp switch (M/T)
CHG15-1	Ignition coil #1(With IMMO.)	CHG55	Front wheel sensor RH
CHG15-2	Ignition coil #2(With IMMO.)	CHG56	Yaw rate sensor
CHG15-3	Ignition coil #3(With IMMO.)	CHG57	Side repeater lamp RH
CHG15-4	Ignition coil #4(With IMMO.)	CHG58	Windshield defogger
CHG16	Oxygen sensor (Up)	CHG59	Head lamp leveling actuator RH
CHG18-1	Ignition coil #1	CHG60	Accel pedal position sensor
CHG18-2	Ignition coil #2	CHG61	Oil pressure switch
CHG18-3	Ignition coil #3	CHG62	Cruise clutch pedal position switch
CHG18-4	Ignition coil #4	CHG-A	PCM
CHG19	Condenser	CHG-K	PCM
CHG21	Purge control solenoid valve	E/R-CHG1	EMS box
CHG22	Oxygen sensor (Down)	E/R-CHG2	EMS box
CHG23	Knock sensor	EC11	Connection with FRONT harness
CHG24-1	Injector #1	FC11	Connection with FLOOR harness
CHG24-2	Injector #2	MC12	Connection with MAIN harness
CHG24-3	Injector #3	MC22	Connection with MAIN harness
CHG24-4	Injector #4	GHG11	Ground
CHG25	Map sensor	GHG12	Ground
CHG28	A/C compressor	GHG13	Ground
CHG29	Ignition lock switch	GHG14	Ground
CHG30	Power steering switch	GHG15	Ground
CHG31	Vehicle speed sensor (M/T)	GHG16	Ground
CHG32	Front wheel sensor RH (W/O ABS/ESP)		
CHG41	ABS control module		
CHG42	ESP control module		

Door Harness (1)

HL-13

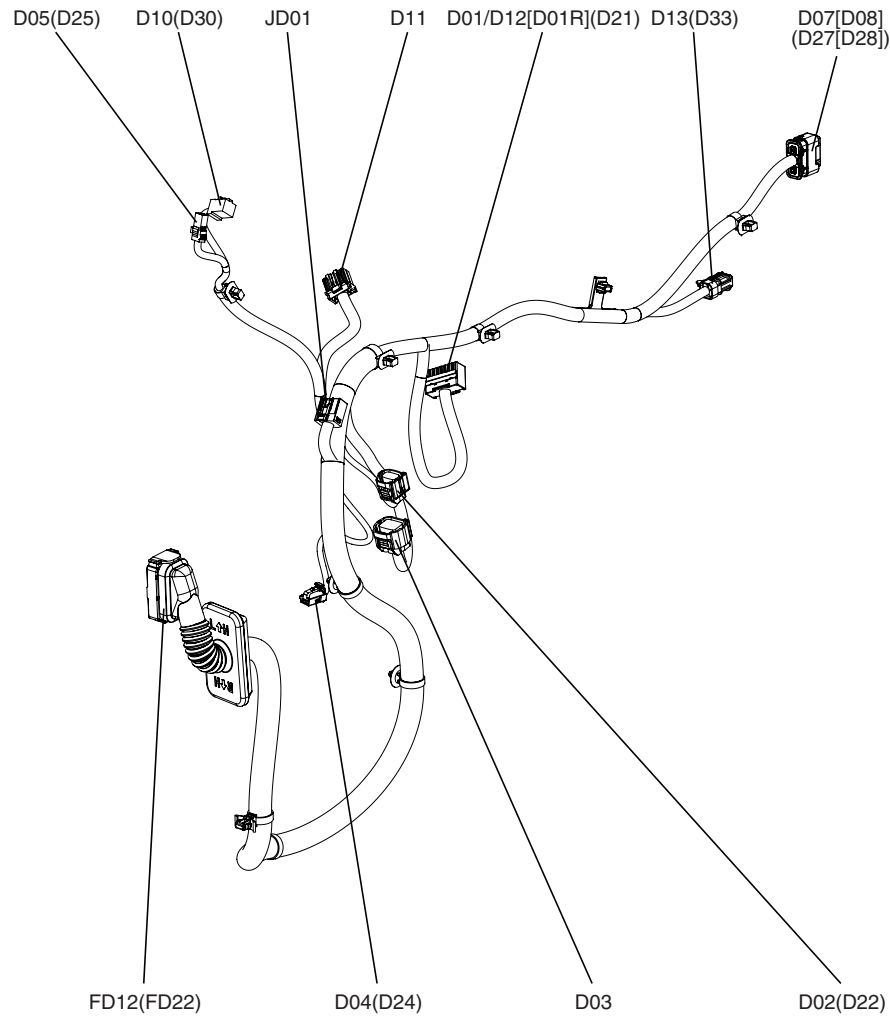

**DRIVER DOOR HARNESS**

- D01 Power window main switch (LHD)
- D01R Power window main switch (RHD)
- D02 Front power window motor LH
- D03 Safety power window module
- D04 Driver door speaker
- D05 Driver tweeter speaker
- D07 Driver door lock actuator (LHD)
- D08 Driver door lock actuator (RHD)
- D10 Driver power outside mirror
- D11 Power outside mirror switch
- D12 Safety power window main switch
- D13 Driver smart key outside handle
- JD01 Joint connector
- FD12 Connection with FLOOR harness

**PASSENGER DOOR HARNESS**

- D21 Passenger power window switch
- D22 Passenger power window motor
- D24 Passenger door speaker
- D25 Passenger tweeter speaker
- D27 Passenger door lock actuator (LHD)
- D28 Passenger door lock actuator (RHD)
- D30 Passenger power outside mirror
- D33 Passenger smart key outside handle
- FD22 Connection with FLOOR harness

( ): RH  
[ ]: RHD

# DOOR HARNESS

## Door Harness (2)

HL-14

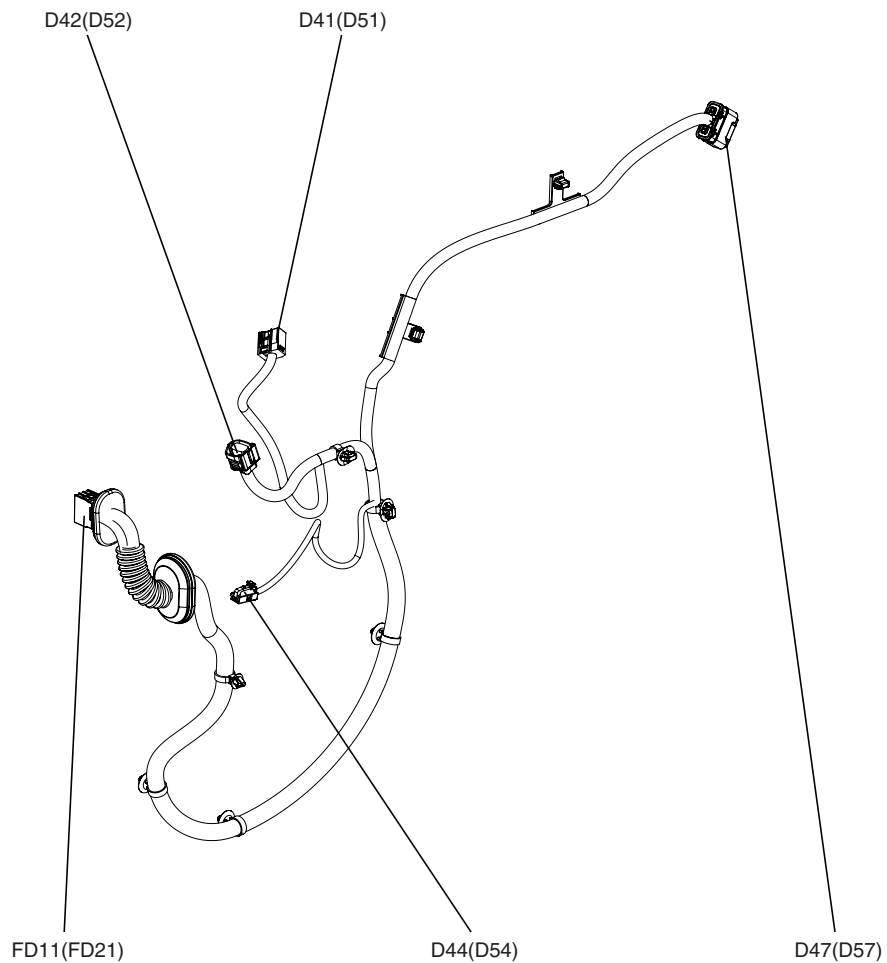

### REAR DOOR LH HARNESS

- D41 Rear power window switch LH
- D42 Rear power window motor LH
- D44 Rear door speaker LH
- D47 Rear door lock actuator LH
- FD11 Connection with FLOOR harness

### REAR DOOR RH HARNESS

- D51 Rear power window switch RH
- D52 Rear power window motor RH
- D54 Rear door speaker RH
- D57 Rear door lock actuator RH
- FD21 Connection with FLOOR harness

( ): RH

Roof Harness (1)

HL-15

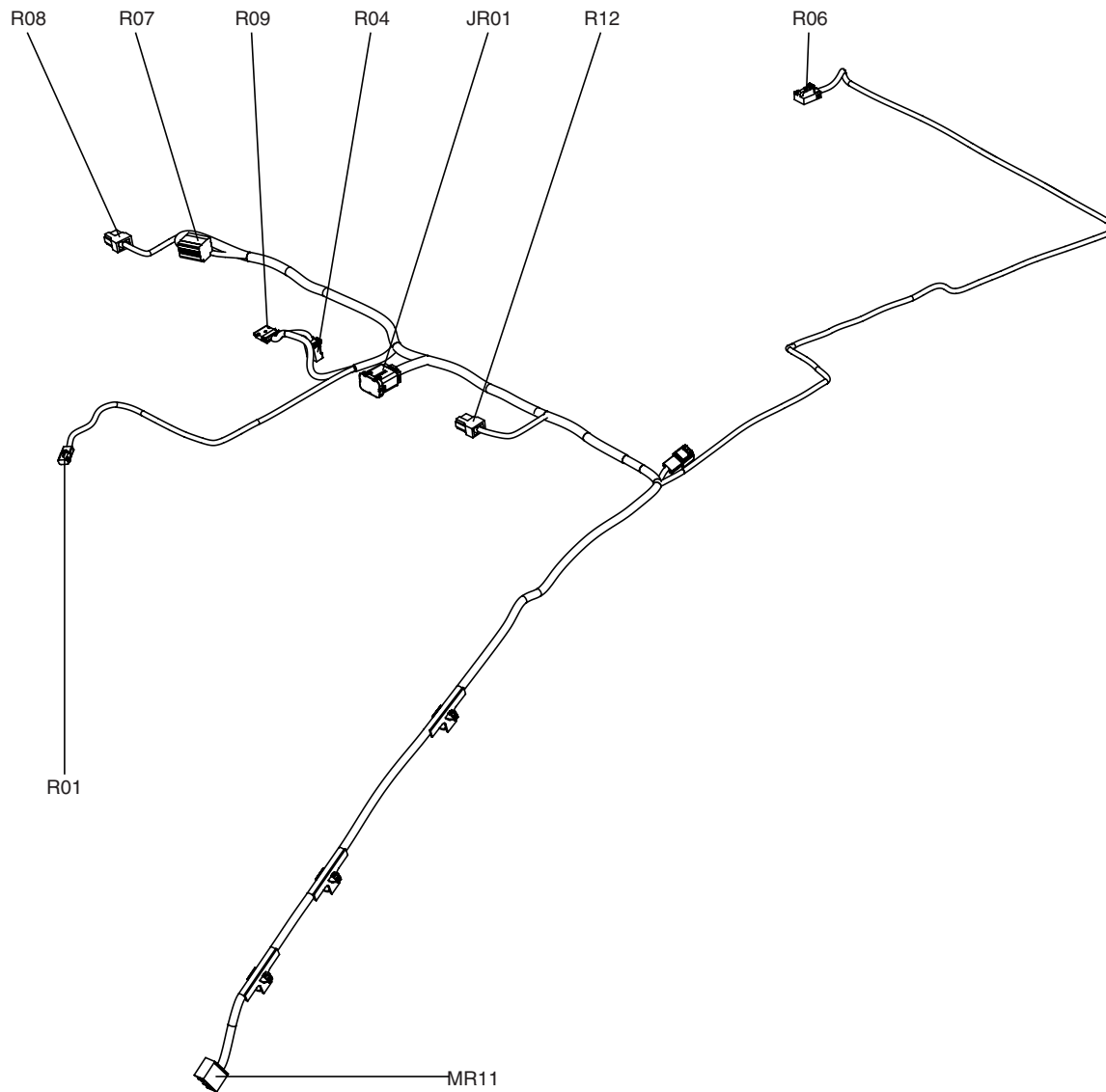

**ROOF HARNESS**

- R01 Electro chromic mirror
- R04 Map lamp
- R06 Room lamp
- R07 Sunroof control module
- R08 Vanity lamp RH
- R09 Sunroof switch
- R12 Vanity lamp LH
- JR01 Joint connector
- MR11 Connection with MAIN harness

**REAR HTD(-) HARNESS**

- R29 Rear defogger(-)
- GR21 Ground

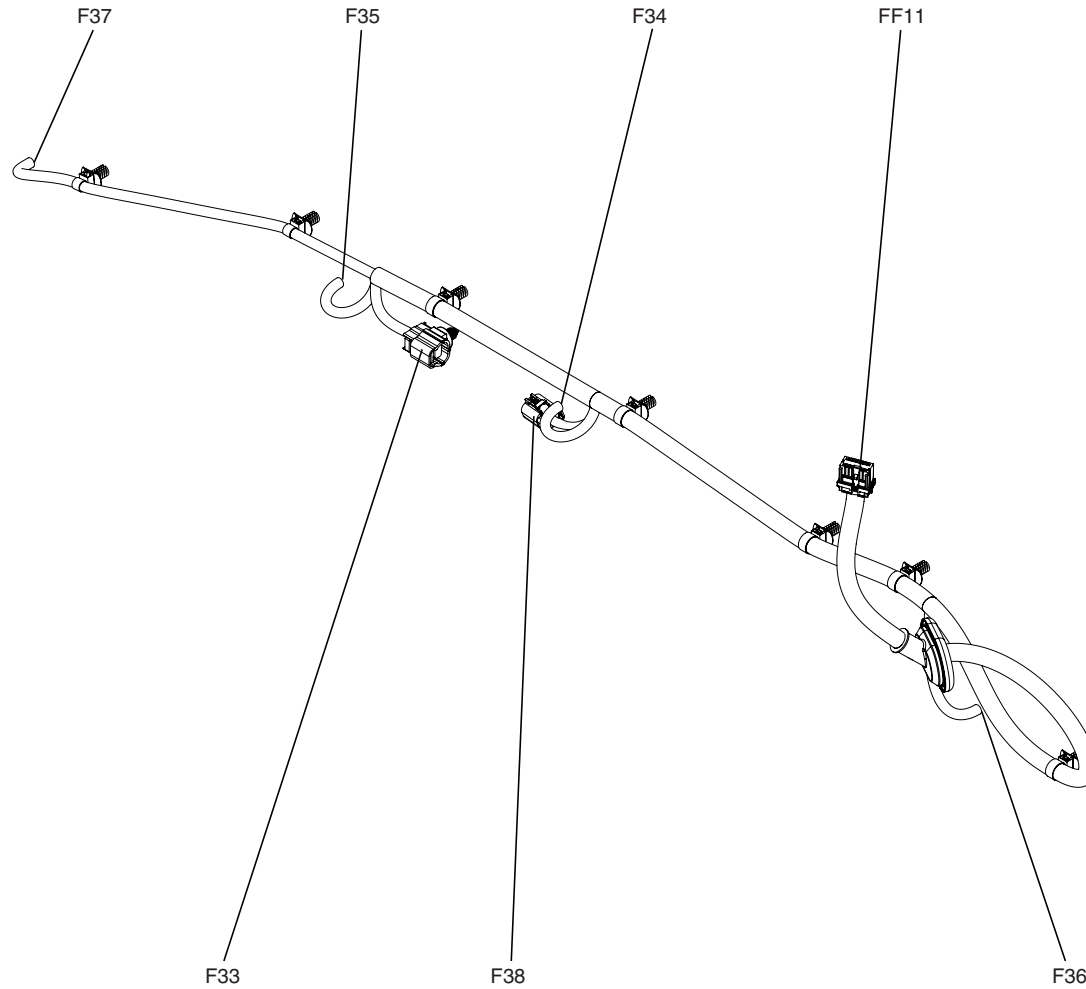

**BWS EXT. HARNESS**

- F33 Smart key antenna (BUMPER)
- F34 Rear parking assist sensor LH
- F35 Rear parking assist sensor RH
- F36 Rear parking assist sensor side LH
- F37 Rear parking assist sensor side RH
- F38 License lamp (2DR) (With rear parking assist )
- FF11 Connection with FLOOR harness